



Enviro-Equipment Inc.
10120 Industrial Drive
Pineville NC 28134

Stock#: 817

Status: In stock, Tested

Dimensions: See cut sheet

Description: Goulds Pump Model 1ST 1C5E4 with 3/4HP 3PH 230/460V 3500RPM TEFC Motor



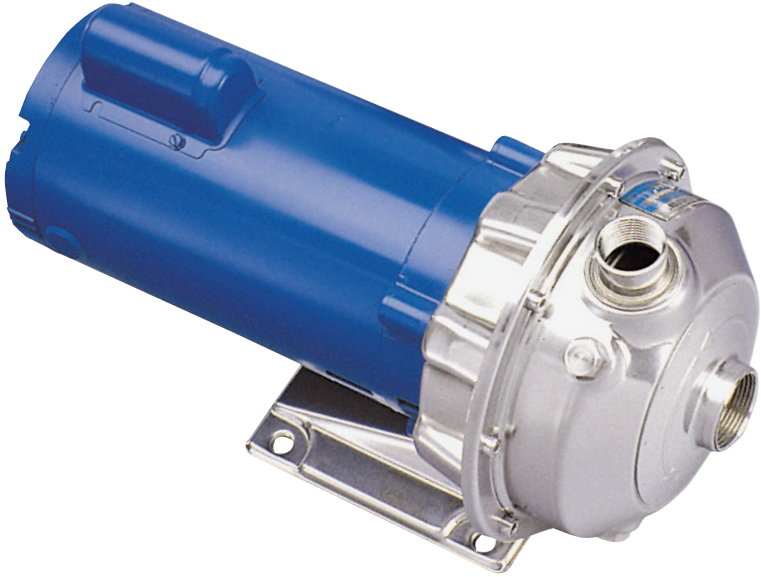

NPE

316L STAINLESS STEEL END SUCTION CENTRIFUGAL PUMPS

BRNPE

 **GOULDS**
WATER TECHNOLOGY
a xylem brand



A FULL RANGE OF PRODUCT FEATURES

- The close coupled compact, flexible design saves space, can be mounted horizontally or vertically, and simplifies maintenance.
- Standard NEMA motors are open drip-proof, totally enclosed fan-cooled or explosion proof enclosure, have stainless steel shaft, and are designed for continuous duty under all conditions with single and three phase available.
- Superior, complete AISI 316L stainless steel liquid handling components for corrosion resistance and improved strength and durability.
- Casing and adapter have NPT threaded centerline connections, easily accessible vent, prime and drain connections with stainless plugs.
- Unique floating O-ring enclosed impeller design maintains maximum efficiencies.
- Standard John Crane mechanical seal of silicon carbide, viton and stainless metal parts with optional high temperature and chemical duty seals available.

TYPICAL APPLICATIONS

Specifically designed for a broad range of general applications traditionally requiring various materials such as all iron, bronze fitted, all bronze or stainless construction.

- Water circulation • Booster service • Liquid transfer • Spray system • Chillers
- Washing/cleaning systems • Injection molding cooling • Reverse osmosis
- Air scrubbers • Heat exchangers • Filtration systems • Jockey pumps
- OEM applications • General water services

SPECIFICATIONS

Capacities to:

- 75 GPM (283L/min) at 1750 RPM
- 150 GPM (550L/min) at 3500 RPM

Working pressures to:

- 125 PSIG (9 bars)

Heads to:

- 39 feet (11 m) at 1750 RPM
- 150 feet (50 m) at 3500 RPM

Maximum temperatures to:

- 212°F (100°C) with standard seal or
- 250°F (121 °C) with optional high temperature seal



MATERIALS OF CONSTRUCTION

NPE Close-Coupled Major Components

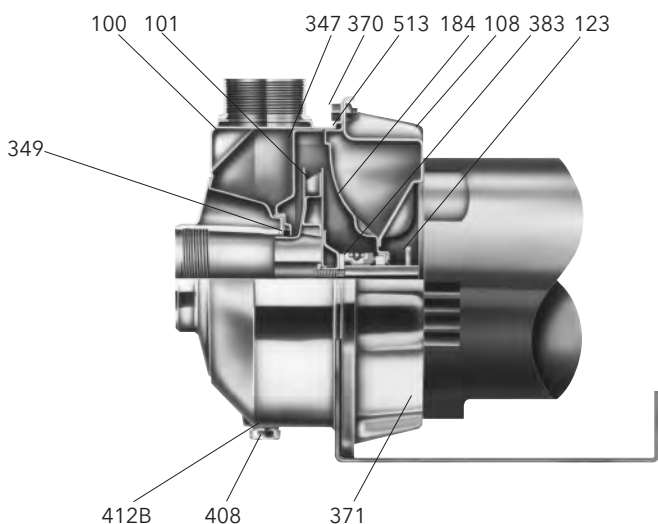

NPE Frame-Mounted Major Components

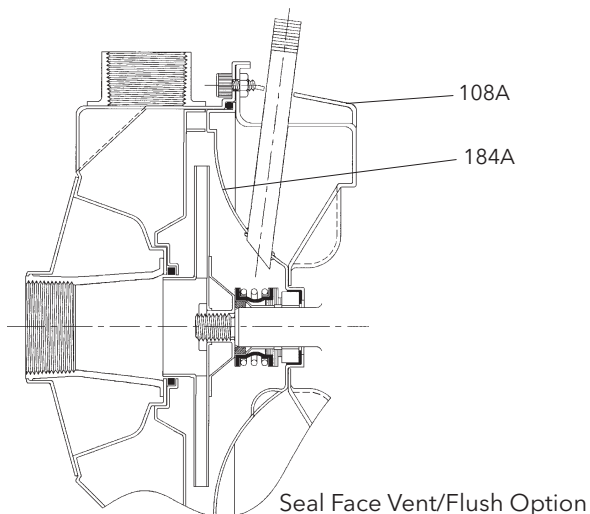
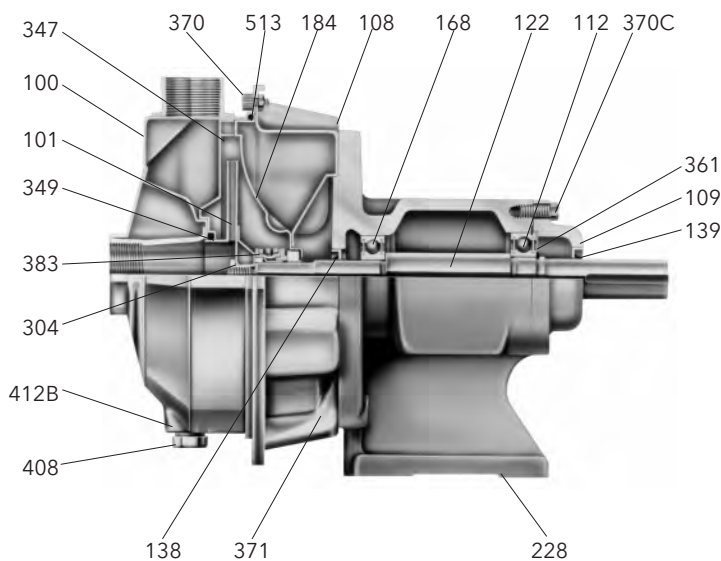

Item No.	Description	Materials
100	Casing	AISI 316 SS
101	Impeller	AISI 316 SS
108	Motor adapter	AISI 304 SS
108A	Motor adapter seal vent/flush	AISI 304 SS
109	Bearing cover	Cast iron
112	Ball bearing (outboard)	Steel
122	Shaft	AISI 316 SS
123	Deflector	BUNA-N
138	Lip-seal (inboard)	BUNA/steel
139	Lip-seal (outboard)	BUNA/steel
168	Ball bearing (inboard)	Steel
184	Seal housing	AISI 316 SS
184A	Seal housing seal vent/flush	AISI 316 SS
228	Bearing frame	Cast iron
304	Impeller locknut	AISI 316 SS
347	Guidevane	AISI 316 SS
349	O-ring	Viton
361	Retaining ring	Steel
370	Socket head screws, casing	AISI 430 SS
370C	Hex head screw, bearing cover	Plated steel
371	Bolts, motor	Plated steel
383	Mechanical seal	Carbon/Sil-Carbide, Viton elastomers, 316 Stainless metal parts*
400	Shaft key	316
408	Drain and vent plug, casing	AISI 316 SS
412B	O-ring, drain and vent plug	Viton
513	O-ring, casing	Viton
Motor	NEMA standard, 56J flange	

*Optional high temperature and chemical duty seals available

NPE PERFORMANCE CURVES 60 Hz USA

METERS FEET

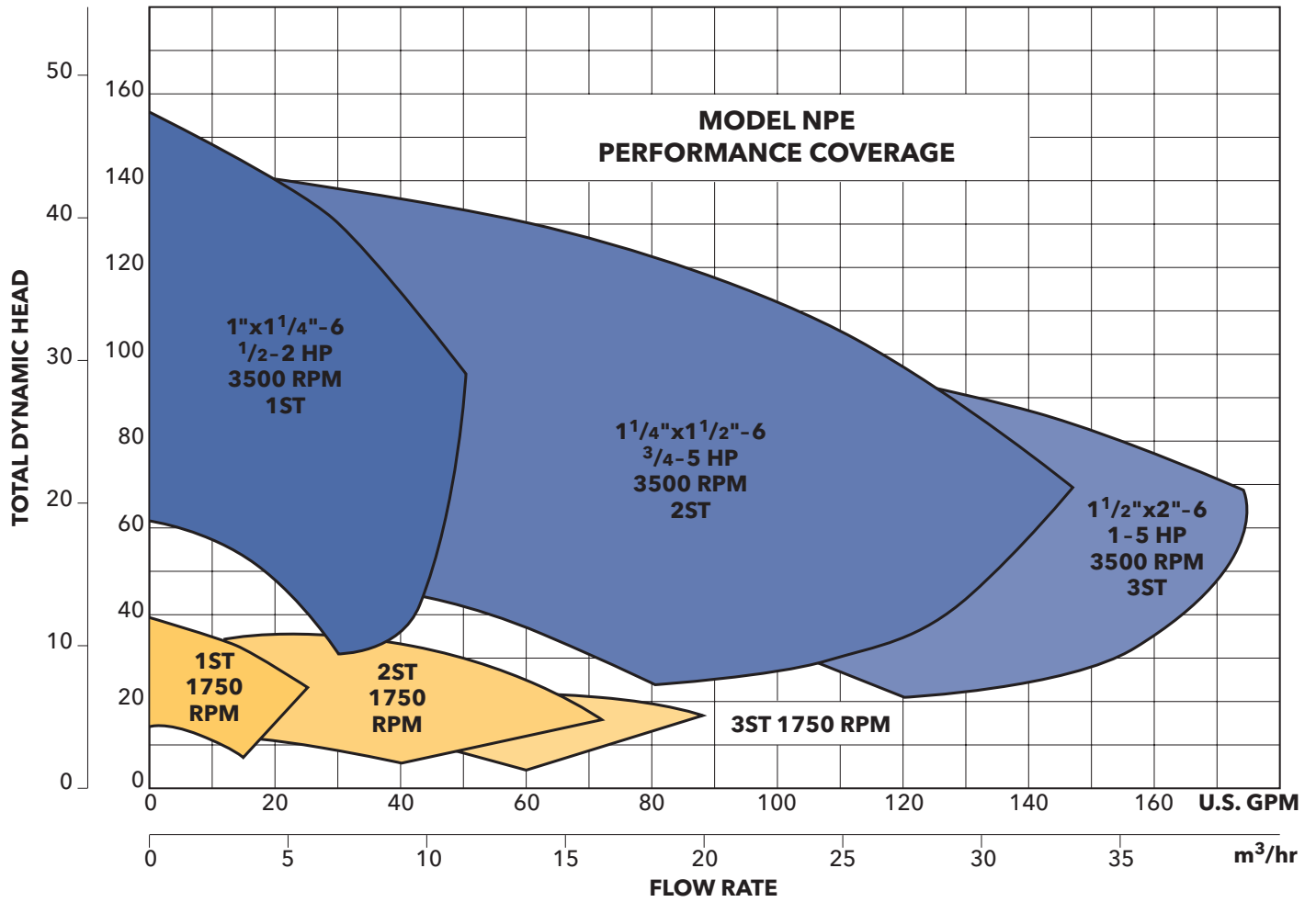

Xylem Inc.
 2881 East Bayard Street Ext.
 Seneca Falls, NY 13148
 Phone: (800) 453-6777
 Fax: (888) 322-5877
www.xyleminc.com/brands/gouldswatertechnology

Goulds is a registered trademark of Goulds Pumps, Inc. and is used under license.
 © 2012 Xylem Inc. BRNPE March 2002