



Enviro-Equipment Inc.  
10120 Industrial Drive  
Pineville NC 28134

Stock#:226

Status: In stock

Dimensions: 18"x8"x8"

Weight: 50 lbs

Description:

**Pump:**

MFG- Price Pumps

Model- CD100B1

Serial- 9581456949-09

Port size- 1.25" in 1" out

**Motor:**

MFG- Leeson

Model- A6T34XC25F

Serial-

CAT#- 11193900

Frame- G56C

Class-

SF-1

AMB- 40C

HP-1.5

RPM- 3450

Voltage- 208-230/460

AMP- 4-4.6/2-2.3

Phase-3

Hz-60

DUTY-Continuous

CODE- K

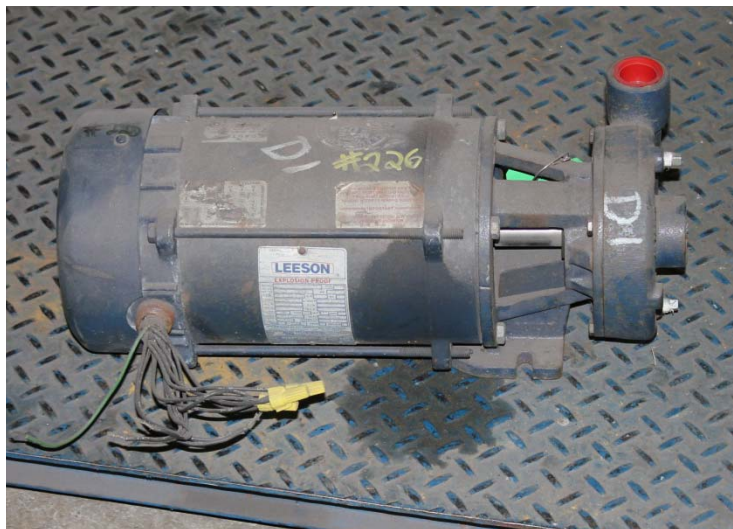

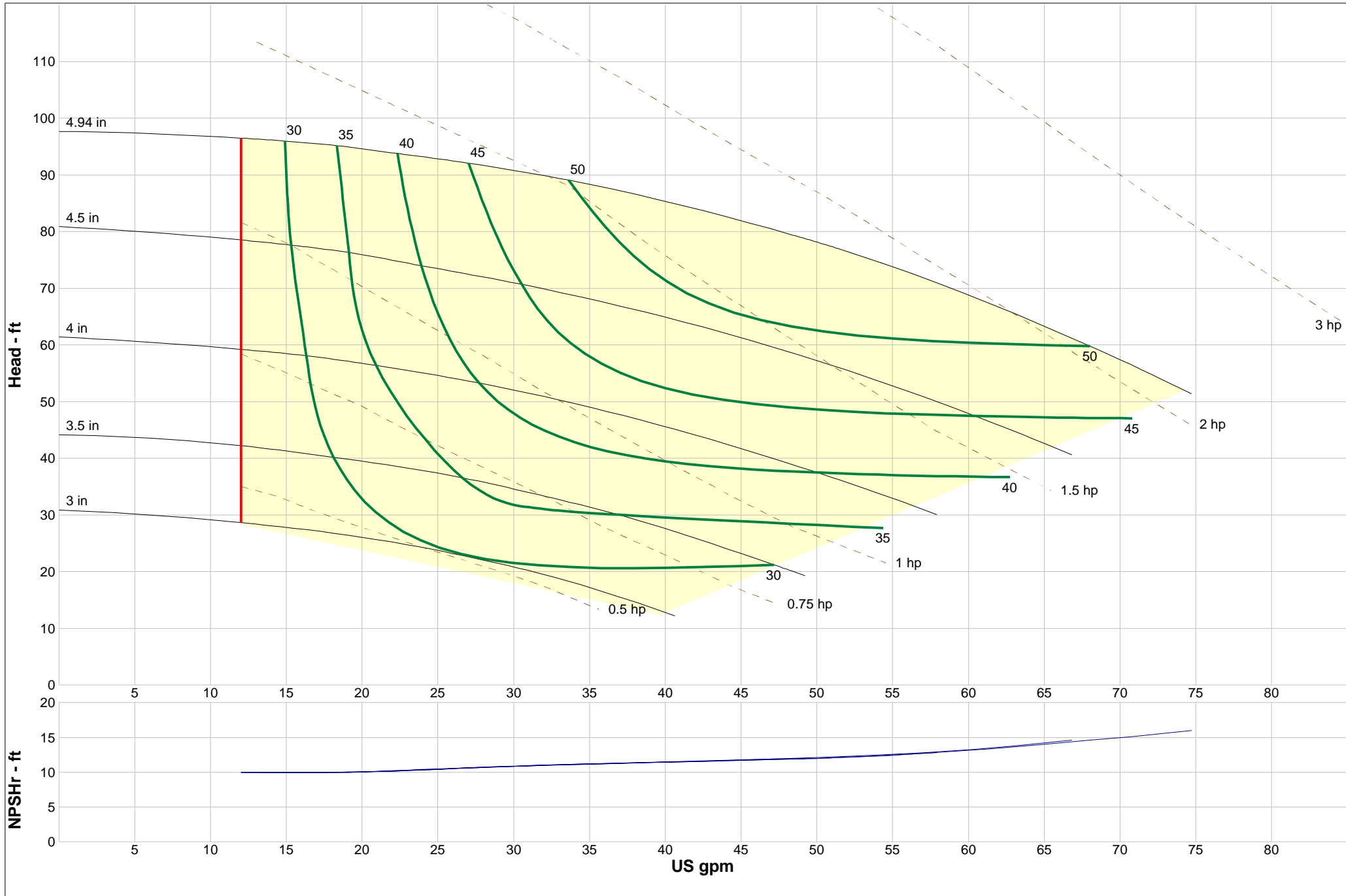

Company:  
Name:  
8/25/2011

Price Pump Company  
Catalog: Price Close Coupled Pumps.60, Vers 1.2  
CD100/CD150 - 3600

Model: CD100 AI/AB  
Speed: 3500 rpm  
Dia: 4.94 in  
Curve: CD001-1





# Price® Pump Company

## Type CD RC Installation, Operating and Maintenance Manual

### Warning:

**Before installing, repairing or performing maintenance on this pump, read these instructions completely.**

**Disconnect power to pump before servicing to avoid dangerous or fatal electrical shock .**

**Match supply voltage to motor nameplate voltage. Incorrect voltage can cause fire or serious motor damage and void warranty.**

**Ground motor before connection to electrical power supply!! Failure to ground motor can cause severe or fatal electrical shock!!  
Do not ground to gas supply line!!**

**Before disassembling pump, be certain all liquid is removed. If pump was used to move hazardous or toxic materials, it must be decontaminated prior to disassembly.**

### Close Coupled Motor

#### Pumps:

It is suggested that these pumps be firmly bolted to a level surface. Adequate air movement around motor will help prevent overheating.

Do not over tighten inlet and outlet piping or volute may fracture.

#### Power Frame Mounted Pumps

These pumps must be mounted on a rigid steel base that will not warp or flex. Each pump must be mounted such that the pump shaft centerline is on center with the driver shaft centerline. Pad and/or shims will be required on either pump, driver or both. The two shafts should not touch each other and the distance between them depends on the coupling used to connect them.

Misalignment will cause vibration, bearing failure and void warranty. Pumps are rough aligned at the factory but must be realigned after shipment and installation.

Pulley driven pump must have pulleys inline and good belt tightness practices followed.

#### Direction of Rotation

**Note:** Motor shaft rotation is viewed from the suction end of pump. A rotational arrow is shown on the front of the pump volute casing. Incorrect rotation can cause pump damage, failure or reduced performance, voiding warranty. It is best to check rotation by momentarily energizing or joggling the motor prior to filling pump with liquid.

**Warning! Do not operate pump without liquid for more than a few seconds, as damage will result to mechanical seal**

#### Plumbing

All piping should be supported independently of the pump. Piping should not exert any stress on the pump connections.

## **Suction Piping**

(Horizontal Pumps)

Suction line must provide adequate suction pressure and smooth liquid flow for proper pump operation. Air in the suction line due to leaks or improper piping design may cause the pump to lose prime. Non-priming pumps must have their suction flooded at start up. Also, the suction line must provide sufficient pressure (NPSH) and smooth flow to pump inlet to prevent pump cavitation. The suction pipe length entering the pump should be a minimum of 5 times and preferably 10 times the pump inlet diameter. Elbows, fittings or valves installed close to the pump inlet can disrupt liquid flow and cause mal-function. Suction lines must be at least the same diameter as the pump inlet or larger if possible.

Price Pump Company recommends against using foot valves in the suction line to maintain liquid in the pump when it's not operating. If foot valves are used, due to suction lift conditions, they must be properly maintained to avoid leaks resulting from wear or fouling. Suction piping must be designed to prevent vapor from being trapped in high spots in the piping. This condition may cause the pump to vapor lock.

## **Discharge Piping**

To control flow and discharge head, it is advisable to install a valve (globe, ball, or other adjustable and non-leak type) in the discharge line close to the pump. The valve may be closed during system repairs to prevent back-flow. By installing a check valve in the discharge line backflow can also be prevented during maintenance or during periods of pump stoppage.

### **Operation**

All centrifugal pumps must be filled with liquid prior to start up. It is suggested that during initial start up the discharge valve be closed and then opened as the motor develops full rpm's. If pump does not build up pressure as motor speed increases, shut down and make sure that liquid flow into pump is not restricted (see "Troubleshooting").

**Note:** A centrifugal pumps flow and head (pressure) will vary with the amount of resistance (friction and flow restrictions) in the discharge line. As a valve on the discharge line opens the flow and motor amp draw will increase and head (pressure) will drop. As a valve on the discharge is closed the flow and amp draw will decrease and the head will

increase.

If resistance in the discharge line is not sufficient the pump will operate at a condition of maximum flow, also sometimes called "end of performance curve." Maximum horsepower is required to operate at this point and motor overload may result. If excessive amp draw and motor overload is recurring, reduce the system flow by installing a valve or orifice in the discharge line and restrict flow.

Alternatively, reduce pump head by trimming impeller to a smaller diameter.

Consult local Price Pump distributor for assistance.

# **TYPE CD/RC MAINTENANCE AND REPAIR**

Before attempting any repairs under warranty, contact Distributor to obtain factory authorization. Repairs carried out without authorization may void warranty. Many causes of pump system failure are due to improper system design. Refer to the trouble shooting list in this manual before carrying out pump inspection.

## **DISASSEMBLY**

1. Disconnect power source to motor.
  2. Disconnect electrical connections tagging wires carefully to preserve correct rotation. Loosen motor base.
  3. Remove pump and motor assembly to repair area.
  4. Remove volute from pump.
  5. Unscrew and remove impeller lockdown and lockwashers. Slide impeller off shaft. Do Not throw shaft key away.
  6. Remove seal head from the shaft. Type 6A: Remove seal head from bracket. Type 21: Slide seal head from the shaft. Type 9: Loosen set screws and slide seal head off shaft.
  7. Remove four motor bolts and remove bracket from motor.
  8. Remove seal seat from bracket. Use wooden or plastic dowel to tamp the seat from the bracket.
1. Clean seat cavity of the bracket thoroughly.
  2. Thoroughly clean pump shaft. Assure that the shaft is not grooved and that there is no evidence of pitting or fretting. If the shaft is grooved, fretted or worn, replace it.
  3. Install the pump shaft onto the motor shaft, aligning set screws of the pump shaft with the keyway of the motor shaft. Install slinger between the pump shaft setscrews.
  4. For Type 6A
    - a. Place bracket on firm surface with seat cavity (pump end) up. Using a tool (1-19/64" ID x 1-5/8" OD x 1/2" deep), press seal into seal cavity with carbon face of seal (volute end up) up. Press until flange is seated in seal cavity of bracket. Press only on outer flange of seal. Avoid touching carbon surface.
    - b. Place bracket on motor (aligning the base if applicable). Secure bracket with four motor bolts.
  - c. Pull pump shaft forward until shoulder of pump shaft contacts back of bracket and slightly snug one setscrew to hold shaft in place.
  - d. Apply small amount of vegetable oil on the pump shaft and I.D. of seat elastomer. Gently place seat on end of shaft with ceramic face down toward seal. After sliding impeller onto shaft, seat will be properly located.
  - e. Slide impeller onto shaft ensuring seat is pushed flush with shoulder of shaft and impeller hub.
  - f. Install shaft key, impeller flatwasher, lockwashers and lockdown bolt.

## **REASSEMBLY**

Tighten securely (10ft.lbs.) Caution: Serviceable Loctite must be used on lockdown bolt. Lockwasher pairs must be assembled cam face to cam face. See diagram

- g. Loosen pump shaft set screw.
  - h. Install new volute gasket/o-ring and mount volute to bracket. Secure with bolts and tighten evenly.
  - i. Setting impeller clearance: Slide pump shaft forward until impeller touches volute. Slide shaft back .010-.015". Tighten pump shaft set screws. Turn shaft by hand to ensure impeller does not rub against volute. Proceed to step 9.
5. For Type 21, 8, 9 seals: Place the bracket on a firm surface with the seat cavity (pump end) up. Then place a small amount of vegetable oil on the seat cup or o-ring seat. Place the seat in the seat cavity with the polished face up toward the pump end. Evenly push seat into cavity with fingers then gently tap seat into place with a

wooden dowel or plastic rod (1-1/8" outside diameter). To help ensure the seat is not damaged place the cardboard disk supplied with the seal over the seat face.

- 6. Place bracket on motor (aligning the base if applicable). Secure bracket with four motor bolts.
- 7. Pull pump shaft forward until shoulder of pump shaft contacts back of bracket and slightly snug one setscrew to hold shaft in place
- 8. Install seal head assembly
  - For Type 21 Seals:
    - a. Lubricate shaft and elastomer with vegetable oil.
    - b. Install rotary seal head onto pump shaft and slide toward seat until carbon face contacts ceramic seat.
  - c. Install seal spring and retainer.
  - d. Install impeller. Install key in pump shaft. Slide impeller onto shaft ensuring that the spring retainer does not slip between the shoulder of the shaft and the hub of the impeller. Install impeller flatwasher,

lockwashers and lockdown. Tighten securely (10 ft. lbs.) Caution:

- Serviceable Loctite must be used on lockdown bolt. Lockwasher pairs must be assembled cam face to cam face. See diagram
- e. Loosen pump shaft set screw.
  - f. Install new volute gasket/o-ring and mount volute to bracket. Secure with bolts and tighten evenly.
  - g. Slide pump shaft forward until impeller touches volute. Slide shaft back with a screwdriver .010-.015". Tighten pump shaft set screws. Turn shaft by hand to ensure impeller does not rub against volute. Proceed to step 9.
- For Type 8 & 9 Seals:
- a. Install impeller. Install key in pump shaft. Slide impeller onto shaft and install impeller washer and lockdown bolt. Tighten securely.

- b. Loosen pump shaft set screw.
- c. Install new volute gasket/o-ring and mount volute to bracket. Tighten at least two bolts at this time.
- d. Slide pump shaft forward until impeller touches volute. Slide shaft back .010"-.015". Tighten pump shaft set screws. Turn shaft by hand to ensure impeller does not rub against volute.
- d. Remove volute and impeller.
- e. Install seal head onto pump shaft sliding gently past shoulder of shaft. Slide seal head toward seat until carbon face contacts ceramic seat. Tighten seal head setscrews to pump shaft. Remove clips in seal head and discard.
- j. Reinstall impeller, flatwasher, lockwashers and lockdown bolt. Tighten securely (10 ft. lbs.)  
Caution:  
Serviceable Loctite must be used on lockdown bolt.  
Lockwasher pairs must be assembled

- cam face to cam face. See diagram
  - k. Install new volute gasket and mount volute to bracket. Secure with bolts and tighten evenly.
  - l. Rotate pump shaft by hand to ensure impeller does not rub against volute.
9. Return pump to installation, reconnect electric connections.
  10. Start pump momentarily to observe shaft rotation. If rotation corresponds to the rotation arrow, pump may be put into service. If rotation is incorrect, switch any two leads on 3-phase motors. Check wiring diagram of motor for single phase rotation.
  11. Remove top pipe plug (if applicable) from the front of volute and prime pump thoroughly, making sure all air is purged.
  12. Start pump allowing adequate time to purge all air from system. Observe any gauges, flow meters, etc. to see of pump performs properly.

DIAGRAM A

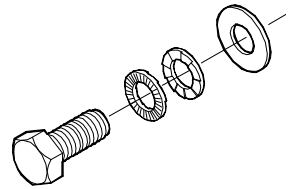

LOCKDOWN ASSEMBLY

## **Double Seal Installation**

### **REASSEMBLY**

1. Clean seat cavity of the bracket and seal plate thoroughly.
2. Thoroughly clean pump shaft. Assure that the shaft is not grooved and that there is no evidence of pitting or fretting. Polish the shaft with extra fine emery cloth and clean the keyway. If the shaft is grooved, fretted or worn, replace it.
3. Install the pump shaft onto the motor shaft, aligning set screws of the pump shaft with the keyway of the motor shaft. Ensure all debris and burrs are removed from the motor shaft and that the slinger is in place.
4. Place bracket on motor (aligning the base if applicable). Secure bracket with four motor bolts.
5. Pull out pump shaft as far as it will go toward volute end and slightly snug one set screw to hold shaft in place
6. Place a small amount of vegetable oil on the seat cup. Install seats into seat plate and bracket with polished faces up. Evenly push seat into seat cavity with fingers, then gently tap seat into place with a wooden dowel or plastic rod (1-1/8" outside diameter).

To help ensure the seat is not damaged, place the cardboard disk supplied with the seal under the end of the dowel to prevent damaging the seat face.

7. Install seal head assembly:

#### **For Type 21:**

- a. Lubricate shaft and elastomer with vegetable oil.
  - b. Install first rotary seal head onto pump shaft and slide toward seat using a twisting motion until carbon face touches seal seat.
  - d. Install second rotary seal head onto shaft sleeve with carbon facing towards pump end.
8. Install seal plate onto pump end of bracket with new gasket and tighten three allen cap-screws evenly (note: use Teflon pipe sealant on bolts).
  9. Install impeller:
    - a. Install key in pump shaft.
    - b. Slide impeller onto shaft.
    - c. Install impeller washer and lockdown. Tighten.
  10. Loosen pump shaft set screw.
  11. Install new volute gasket, or O-ring and mount volute . Secure with bolts and tighten evenly.
  12. Move shaft back with a screwdriver .010-

.015". Tighten pump shaft set screws. Turn shaft by hand to ensure impeller does not rub against volute.

13. Return pump to installation, reconnect electric connections.
14. Start pump momentarily to observe shaft rotation. If rotation corresponds to the rotation arrow on the pump, it may be put into service. If rotation is incorrect, switch any two leads on 3-phase motors to change rotation. Check wiring diagram of motor for single phase rotation correction.
15. Remove top pipe plug (if applicable) from the front of volute and prime pump thoroughly, making sure all air is purged. Turn shaft one revolution and then refill. Replace the pipe plug.
16. Start pump allowing adequate time to purge all air from system. Observe any gauges, flow meters, etc., to see if pump performs properly.



## DOUBLE SEAL COOLING FLOW RATE CHART

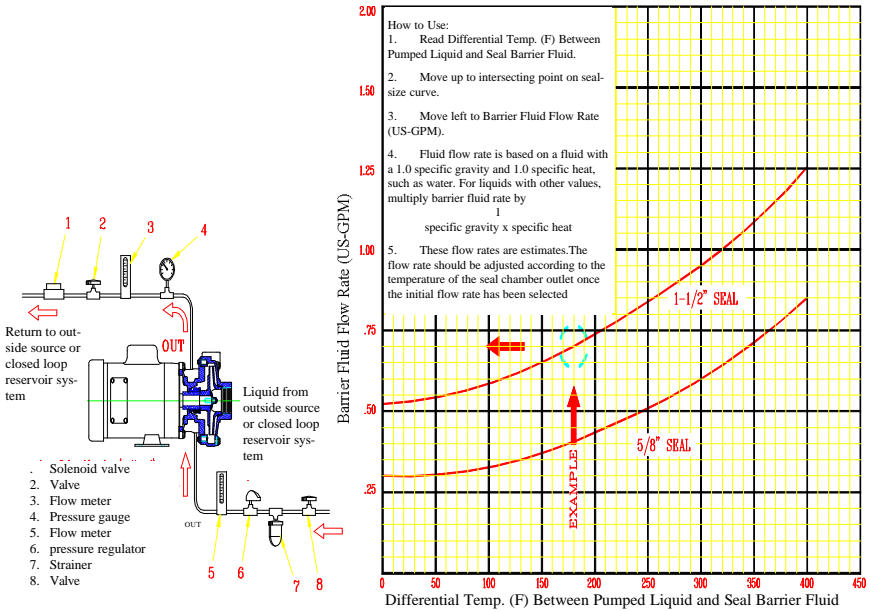

### Double Seal Piping Instructions

1. Piping of the double seal arrangement should be done in accordance with all governmental regulations and safety codes.
  2. All double seals require a barrier flush between the seal for proper lubrication and cooling. The barrier liquid must be maintained at 10-15 PSIG above the discharge pressure of the pump and it must be chemically compatible with the pumped liquid, material construction of the pump, and seals (5/8" double seals have 18-8 parts).
  3. The barrier flush shall have a minimum flow rate in accordance with the graph below. If water is used as a fluid, the inlet temperature should not exceed 140 deg F.
  4. A positive pressure must be maintained to the barrier flush between the seal faces even when the pump is not running. To conserve the barrier liquid, a solenoid valve (item 1) may be installed and connected electrically in parallel with the motor so the barrier fluid flows only when the pump is running.
- Note: The maximum pressure of the barrier fluid at the inlet is 150 PSIG.
5. The inlet should be connected to the bottom and the outlet to the top of the seal cavi-

### Procedures For Checking Double Seals for Leakage

#### Option 1: (2 flow meters)

Install flow meters on the inlet and outlet lines. Normal operating conditions will be indicated by equal or near equal flow on both flow meters. If the inlet flow meter shows more flow than the outlet, this could indicate excessive leakage.

#### Option 2: (1 flow meter)

1. Shut off flow at outlet needle valve (item 2).
2. Shut off inlet gate valve (item 8) for 15 seconds maximum.
3. If pressure in seal cavity drops rapidly rather than gradually while the gate valve is closed, the seal is leaking excessively.
4. To restart, open gate valve first then reset valve on outlet.

# RC PARTS LIST

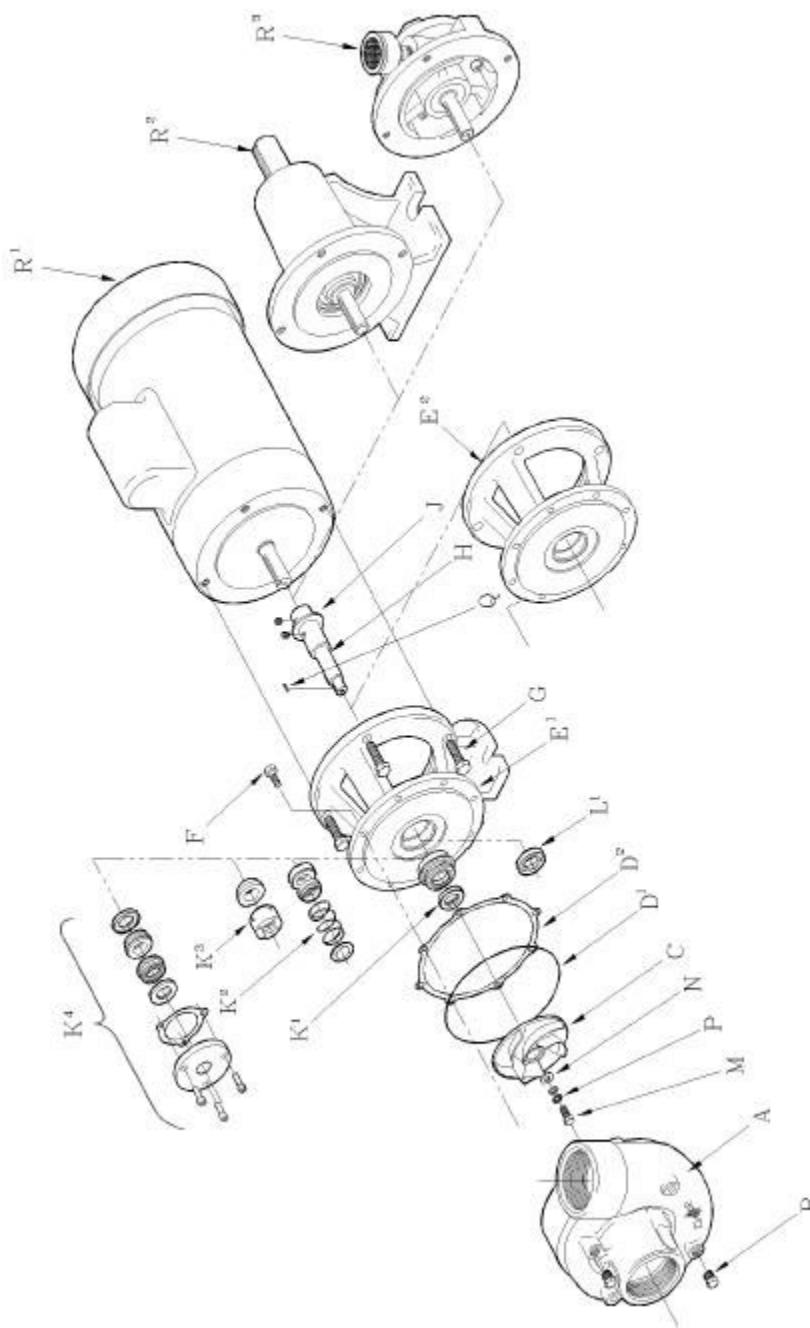

# TYPE RC PARTS LIST

		<b>RC200</b>	<b>RC300</b>		<b>RC200</b>	<b>RC300</b>
A.	Volute	0183	0120	L. T. 6A Quench lip seal, Viton®	0899	0899
B.	Pipe plug	0557	0557	M. Impeller lockdown bolt	0575	0575
C.	Impeller (specify diameter)			N. Impeller lockdown washer	2423	2423
	All iron	4184-dia.	4230-dia.	P. Impeller lockwasher (2 req.)	2344	2344
	Bronze fitted	4128-dia.	4119-dia.	Q. Impeller key	2424	2424
D.	Gasket (volute flange)	0506	0506	R <sub>1</sub> . Motor - specify P/N		
E <sub>1</sub> .	Bracket with foot	2426	2426	R <sub>2</sub> . Power Frame		
E <sub>2</sub> .	Bracket without foot	2428	2428	For use w/ 5/8" shaft	5478	5478
F.	Volute bolts (8 req.)	0573	0573	For use w/ 7/8" shaft	5501	5501
G.	Motor bolts (4 req.)	0588	0588	R <sub>3</sub> . Air motor - specify P/N		
H.	Shaft w/ setscrews 5/8" I.D.	2421-1	2421-1			
I.	Shaft w/ setscrews 7/8" I.D.	2422-1	2422-1			
J.	Slinger	0522	0522			
<b>Seal/seat</b>						
K <sub>1</sub> .	T. 6A Buna, carbon vs ceramic	0538	0538	<b>RC Repair Parts Kit</b>		
K <sub>2</sub> .	T. 21 Viton®, carbon vs ceramic	0553	0553	Repair Kit f/ 5/8" keyed shaft	P/N 2204	
K <sub>3</sub> .	T. 9 Teflon®, carbon vs ceramic	1150	1150	Repair Kit f/ 7/8" keyed shaft	P/N 2204-1	
K <sub>4</sub> .	Double seal arrangement			Kit includes: Gasket (volute flange), pump shaft w/setscrews, slinger, impeller lockdown and key		
	T. 21 Viton®, carbon vs ceramic	0985	0985			
	T. 21 Neoprene, carbon vs ceramic	0984	0984			
	T. 21 EPR, carbon vs ceramic	1023	1023			
	Double seal plate	0973	0973			
	Seal plate gasket, Teflon®	0974	0974			
	Seal plate bolts (3 req.)	0256	0256			

**Note: Seal/seat must be ordered in addition to kit**

# TYPE CD AI, BF, AB PARTS LIST

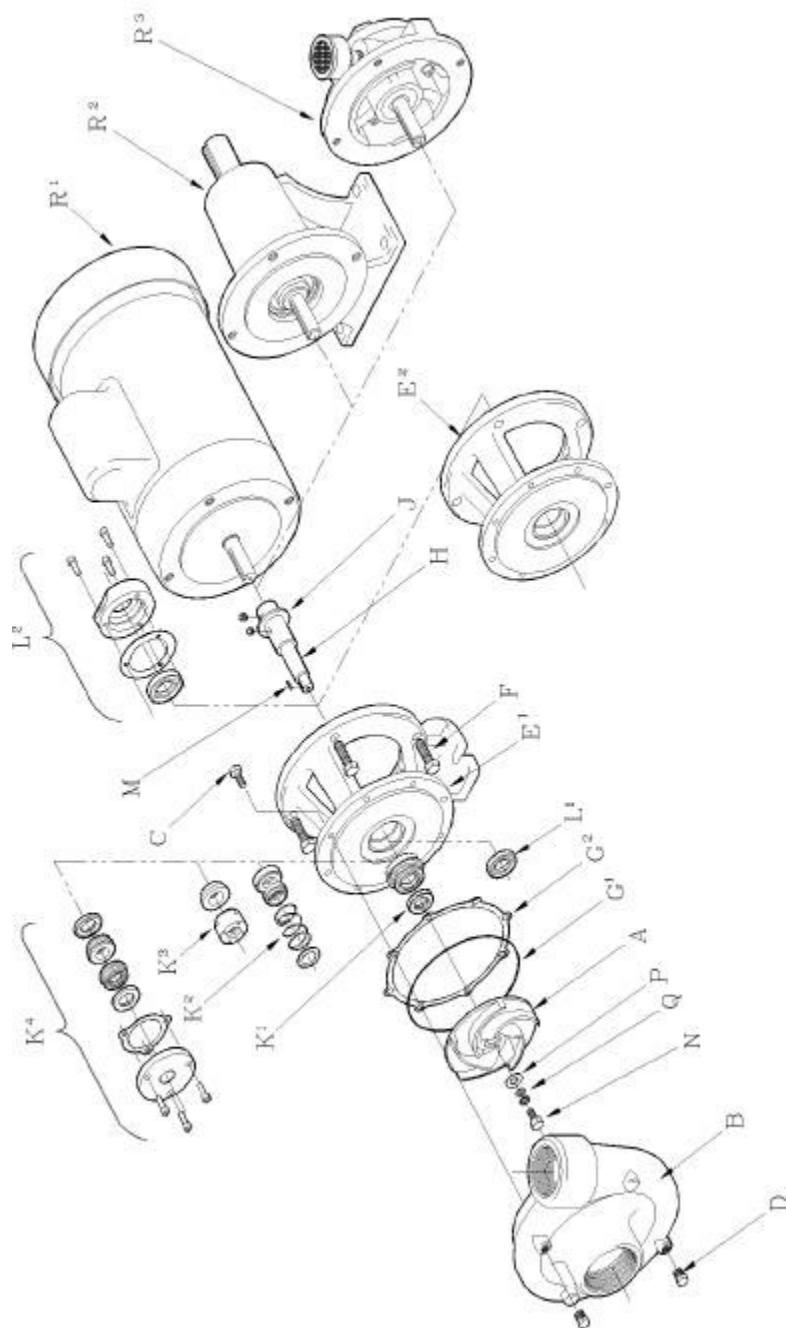

A.	Impeller / specify diameter	<b>CD100AI</b>	<b>CD100BF</b>	<b>*CD100AB</b>	<b>*CD150AI</b>	<b>*CD150BF</b>	<b>*CD150AB</b>
B.	Volute	2402-dia.	2404-dia.	2404-dia	2408-dia.	2410-dia	2410-dia.
C.	Volute bolt	2401	2401	2403-0	2407-0	2407-0	2409-0
D.	Pipe plug	0573 (4 req)	0573 (4 req)	0376 (4 req)	0573 (8 req.)	0573 (8 req)	0376 (req)
E <sup>1</sup> .	Bracket with foot	0557	0557	0558	0557	0557	0558
E <sup>2</sup> .	Bracket without foot	2426	2426	2400	2426	2426	2400
F.	Motor bolt (4 req.)	2428	2428	2440	2428	2428	2440
G <sup>1</sup> .	O-Ring volute gasket	0588	0588	0592	0588	0588	0592
	Buna (standard)	n/a	n/a	3074	3074	3074	3074
	Fluorocarbon	n/a	n/a	3070	3070	3070	3070
	PTFE	n/a	n/a	3071	3071	3071	3071
	Neoprene	n/a	n/a	3072	3072	3072	3072
	EPR	n/a	n/a	3073	3073	3073	3073
G <sup>2</sup> .	Gasket, fiber	0506	0506	n/a	n/a	n/a	n/a

**Part.No..All Models**

H.	Shaft 5/8" I.D.	2421-1
	Shaft 7/8" I.D.	2422-1
J.	Slinger	0522
	<b>Seal/Seat</b>	
K <sup>1</sup> .	T6A Buna (standard)	0538
	T6A Fluorocarbon	0539
K <sup>2</sup> .	T21 Fluorocarbon	0553
K <sup>3</sup> .	T9 PTFE	1150
K <sup>4</sup> .	Double seal/seat	
	T21 Fluorocarbon	0985 (2ea. required)
	T21 Neoprene	0984
	T21 EPR	1023
	Double seal plate	0973
	Gasket PTFE/0974	
	Bolt	0977 (3ea. required)
L <sup>1</sup> .	T6A, quench lip seal Fluorocarbon	0899
L <sup>2</sup> .	T21 quench opt. (for 5/8" shaft pumps only)	
	Quench Plate/0308	
	Plate Gasket, Syn. Fiber	0504
	Plate Bolts (3 req.)	0267
	Fluorocarbon Lip Seal	0891
M.	Impeller key/2424	

**Part.No..All Models**

N.	Impeller lockdown	0575
P.	Impeller flatwasher	2423
Q.	Impeller lockwashers	2344
R <sup>1</sup> .	Motor - specify part number	
R <sup>2</sup> .	Power Frame	
	For use with 5/8" I.D. shafts	5478
	For use with 7/8" I.D. shafts	5501
R <sup>3</sup> .	Air motor - specify part number	

**CD (AI, BF, AB) Repair Parts Kit**

P/N 2222 Includes: 5/8" Shaft , Slinger, Impeller lockdown assy., and impeller key.

P/N 2222-1 Includes: 7/8" shaft, slinger, Impeller lockdown assy., and impeller key.

**NOTE:** Must order Gasket or O-ring and Seal/Seat separately.

# TYPE CDSS PARTS LIST

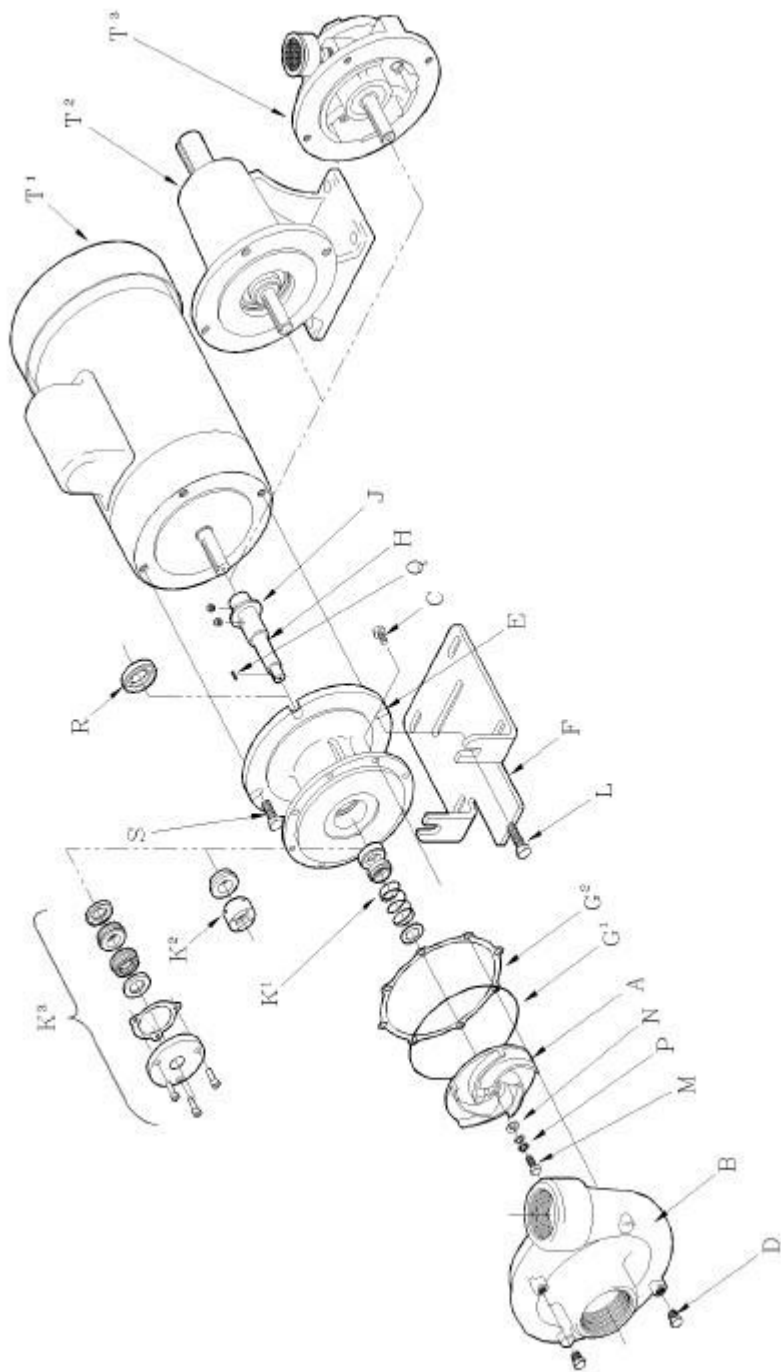

**CD100SS**

A. Impeller	2448-dia.	2412-dia.	Seal plate bolts (3 req.)	0256
B. Volute	0247	2411-0	Motor bolt	0673
C. Volute bolt (8 req.)	0917	0917	Impeller lockdown bolt	0575
D. Pipe plug	0559	0559	Impeller lockdown washer	2423
E. Bracket	0972	0972	Impeller lockwasher (2 req.)	2344
F. Pump Base	0199	0199	Impeller key	2424
G <sub>1</sub> . O-ring (for volute flange)			Fluorocarbon Quench lip seal	0891
	3070	3070	Motor bolt (2 req.)	0593
	3074	3074	Motor - specify P/N	
	3071	3071	Power Frame	
	3072	3072	For use w/ 5/8" shaft	5478
	3073	3073	For use w/ 7/8" shaft	5501
	0507	N/A	Air motor - specify P/N	

**CD150SS**

	2421-1	2421-1		
	2422-1	2422-1		
	0522	0522		

**CDI50SS**

	0553	0553		
	1150	1150		
	0985	0985		
	0984	0984		
	1023	1023		

**CD (AI, BF, AB) Repair Parts Kit**

			P/N 2205	Includes: 5/8" Shaft, Slinger, Impeller lockdown assy., and impeller key.
			P/N 2205-1	Includes: 7/8" shaft, slinger, Impeller lockdown assy., and impeller key.

**CD100SS**

	0973	0973		
	0974	0974		

**CDI50SS**

	0973	0973		
	0974	0974		

**NOTE:** Must order Gasket or O-ring and Seal/Seat separately.

**TYPE RC**

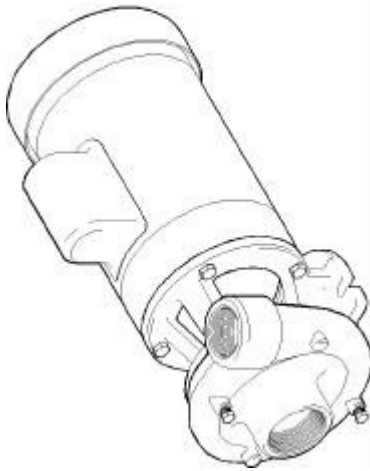
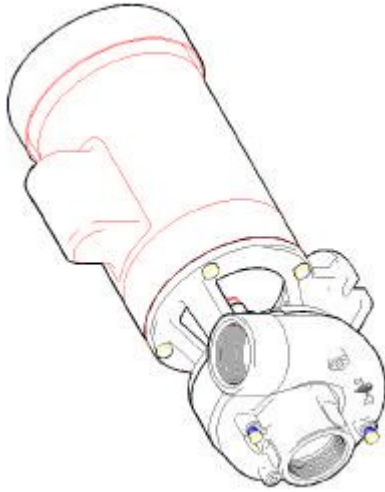

**TYPE CD**



# TROUBLESHOOTING

## **1. Pump fails to build pressure:**

Check for:

- a. Pump not primed.
- b. Incorrect rotation.
- c. Driver speed too low.
- d. Suction line restricted.
- e. Driver failure.
- f. Plugged or damaged impeller.
- g. Pump or impeller undersized.
- h. Pump cavitation.
- i. Improper impeller clearance.

## **2. Pump fails to provide enough flow.**

Check for:

- a. System resistance too high.
- b. Pump undersized.
- c. Pump not primed.
- d. Driver speed too low.
- e. Poor suction conditions.
- f. Improper impeller clearance.

## **3. Excessive noise or vibration during operation.**

Check for:

- a. Motor bearing failing.
- b. Pump cavitating.
- c. Improper impeller clearance.

## **4. Leaking mechanical seal.**

Check for:

- a. Improper assembly.
- b. Worn or cracked seal faces.
- c. Abrasive material in fluid.
- d. Liquid flashing at seal faces (fluid temperature too high).
- e. Seal pressure rating too low for the service.
- f. Chemical attack of seal parts.
- g. Seal operated dry or with a liquid having poor lubricating properties.

## **5. Pump gradually loses pressure and head.**

Check for:

- a. Increasing temperature causing cavitation or liquid vaporization.
- b. Driver failure.
- c. Suction lift too high.
- d. Air entering suction line.

## **6. Motor/pump overheating.**

Check for:

- a. Excessive flow and amp draw (Throttle discharge).
- b. Low voltage or frequency.
- c. Flow too low with resulting heat rise.
- d. Bearing failure.
- e. System temperature too high.

If all else fails, call your distributor or Price Pump @ (707) 938-8441



# General Terms Of Sale For Products

Effective: January 1, 2001

## 1. GENERAL

A. Seller's price is based on these sales terms and conditions. This contract shall represent the final, complete and exclusive statement of the agreement between the parties and may not be modified, supplemented, explained or waived by parol evidence, any Terms and Conditions contained in Buyer's purchase order or request for quotation, any course of dealings between the parties, Seller's performance or delivery, or in any other way. The Terms and Conditions of this contract may only be modified or waived in a written document signed by an Officer of Seller. These terms are intended to cover all activity of Seller and Buyer hereunder, including sales and use of products, parts and work and all related matters (references to products include parts and references to work include construction, installation and start-up). Any reference by Seller to Buyer's specifications and similar requirements are only to describe the products and work covered hereby and no warranties or other terms therein shall have any force of effect. Any information provided by Seller including, but not limited to, suggestions as to specific equipment does not imply any guarantee of specific suitability and/or material compatibility in a particular application, since many factors outside the control of Seller may affect the suitability of products in a particular application. Catalogs, circulars and similar pamphlets of the Seller are issued for general information purposes only and shall not be deemed to modify the provisions hereof.

B. The agreement formed hereby and the language herein shall be construed and enforced under the Uniform Commercial Code as in effect in the State of California on the date hereof.

## 2. TAXES

Any sales, use or other similar type taxes imposed on this sale or on this transaction are not included in the price. Such taxes shall be billed separately to the Buyer. Seller will accept a valid exemption certificate from the Buyer if applicable; however, if an exemption certificate previously accepted is not recognized by the governmental taxing authority involved and the Seller is required to pay the tax covered by such exemption certificate. Buyer agrees to promptly reimburse Seller for the taxes paid.

## 3. PERFORMANCE, INSPECTION AND ACCEPTANCE

A. Unless Seller specifically assumes installation, construction or start-up responsibility, all products shall be finally inspected and accepted within thirty (30) days after arrival at point of delivery. Products not covered by the foregoing and all work shall be finally inspected and accepted within thirty (30) days after completion of the applicable work by Seller. All claims whatsoever by Buyer, (including claims for shortages) except only those provided for under the WARRANTY AND LIMITATION OF LIABILITY and PATENTS Clauses, hereof, must be asserted in writing by Buyer within said thirty (30) day period or they are waived. If this contract involves partial performance, all such claims must be asserted within said thirty- (30) day period for each partial performance. There shall be no revocation of acceptance. Rejection may be only for defects substantially impairing the value of products or work and Buyer's remedy for lesser defects shall be those provided for under the WARRANTY AND LIMITATION OF LIABILITY Clause.

B. Seller shall not be responsible for non-performance or for delays in performance occasioned by any causes beyond Seller's reasonable control, including, but not limited to, labor difficulties, delays of vendors or carriers, fires, governmental actions, or shortages of material, components, labor, or manufacturing facilities. Any delays so occasioned shall affect a corresponding extension of Seller's performance dates, which are, in any event, understood to be approximate. In no event shall Buyer be entitled to incidental or consequential damages for late performance or for a failure to perform. Seller reserves the right to make partial shipments and to ship products, parts or work

which may be completed prior to the scheduled performance date.

C. In the event that Seller has agreed to mount motors, turbines, gears, or other products which are not manufactured by Seller and which are not an integral part of Seller's manufactured product, and a delay in the delivery of such products to Seller occurs that will cause a delay in Seller's performance date, Seller reserves the right to ship its product upon completion of manufacture and to refund an equitable portion of the amount originally included in the purchase price for mounting without incurring liability for non-performance.

D. Seller reserves to itself the right to change its specifications, drawings and standards if such changes will not impair the performance of its products, and parts, and further that such products, and parts, will meet any of Buyer's specifications and other specific product requirements which are a part of this agreement.

E. The manufacture and inspection of products and parts shall be to Seller's Engineering and Quality Assurance standards plus such other inspections or tests of documentation as are specifically agreed to by Seller. Requirements for any additional inspection, tests, documentation, or Buyer witness of manufacture, test, and/or inspection shall be subject to additional charges.

## 4. TITLE AND RISK OF LOSS

Title and risk of loss shall pass to buyer upon delivery of products at the designated "Ex Works" as defined by Incoterms 1990, unless other wise agreed by the parties.

## 5. EROSION AND CORROSION

It is specifically understood that products and parts sold hereunder are not warranted for operation with erosive or corrosive fluids. No product or part shall be deemed to be defective by reason of failure to resist erosive or corrosive action of any fluid and Buyer shall have no claim whatsoever against Seller therefore.

## 6. WARRANTY AND LIMITATION OF LIABILITY

A. Seller warrants only that its product and parts, when shipped, will be free from defects in materials and workmanship. With respect to products and parts not manufactured by Seller, Seller's only obligation shall be to assign to Buyer, to the extent possible, whatever warranty Seller requires from the manufacturer. All claims for defective products or parts under this warranty must be made in writing immediately upon discovery and, in any event, within one (1) year after initial start-up or eighteen (18) months after shipment, whichever first occurs, and all claims for defective work must be made in writing immediately upon discovery and in any event, within one (1) year of completion thereof by Seller. Defective items must be held for Seller's inspection and returned to the sellers' point of original shipment upon request.

UNAUTHORIZED DISASSEMBLY OR TAMPERING WITH ANY PRODUCT OR COMPONENT MAY VOID ITS WARRANTY. THE FOREGOING IS EXPRESSLY IN LIEU OF ALL OTHER WARRANTIES WHATSOEVER, EXPRESS, IMPLIED AND STATUTORY, INCLUDING WITHOUT LIMITATION, THE IMPLIED, WARRANTIES OF MERCHANTABILITY AND FITNESS.

B. ANY PRODUCT (S) SOLD HEREUNDER WHICH IS NOT MANUFACTURED BY SELLER IS NOT WARRANTED BY SELLER and shall be covered only by the express warranty, if any, of the manufacturer thereof.

C. Upon Buyer's submission of a claim as provided above and its substantiation, Seller shall at its option either (i) repair or replace its product, part or work at the original place of shipment, or (ii) refund an equitable portion of the purchase price.

## D. THE FOREGOING IS SELLER'S ONLY

OBLIGATION AND BUYER'S EXCLUSIVE REMEDY FOR BREACH OF WARRANTY AND, EXCEPT FOR GROSS NEGLIGENCE, WILLFUL MISCONDUCT, AND REMEDIES PERMITTED UNDER THE PERFORMANCE, INSPECTION AND ACCEPTANCE AND THE PATENTS CLAUSES HEREOF, THE FOREGOING IS BUYER EXCLUSIVE REMEDY AGAINST SELLER FOR ALL CLAIMS ARISING HEREUNDER OR RELATING HERETO WHETHER SUCH CLAIMS ARE BASED ON BREACH OF CONTRACT, TORT (INCLUDING NEGLIGENCE) OR OTHER THEORIES. BUYER'S FAILURE TO SUBMIT A CLAIM AS PROVIDED ABOVE SHALL SPECIFICALLY WAIVE ALL CLAIMS FOR DAMAGES OR OTHER RELIEF, INCLUDING BUT NOT LIMITED TO CLAIMS BASED ON LATENT DEFECTS. IN NO EVENT SHALL BUYER BE ENTITLED TO INDIRECT, SPECIAL, INCIDENTAL OR CONSEQUENTIAL DAMAGES, NOR FOR DAMAGES FOR LOSS OF USE, LOST PROFITS OR REVENUE, INTEREST, LOST GOODWILL, WORK OR PRODUCTION STOPPAGE, IMPAIRMENT OF OTHER GOODS, INCREASED EXPENSES OF OPERATION, OR THE COST OF PURCHASING REPLACEMENT POWER OR OTHER SERVICES BECAUSE OF SERVICE INTERRUPTIONS. FURTHERMORE, IN NO EVENT SHALL SELLER'S TOTAL LIABILITY FOR DAMAGES OF BUYER EXCEED THE PURCHASE PRICE OF THE PRODUCTS OR PARTS MANUFACTURED BY SELLER AND UPON WHICH SUCH LIABILITY IS BASED. ANY ACTION ARISING HEREUNDER RELATED HERETO, WHETHER BASED ON BREACH OF CONTRACT, TORT (INCLUDING NEGLIGENCE) OR OTHER THEORIES, MUST BE COMMENCED WITHIN ONE (1) YEAR AFTER THE CAUSE OF ACTION ACCRUES OR IT SHALL BE BARRED.

## 7. PURCHASER'S REPRESENTATIONS & WARRANTIES

Purchaser represents and warrants that the product(s) covered by this contract shall not be used in or in connection with a nuclear facility or application. The parties agree that this representation and warranty is material and is being relied on by seller. This provision may be modified in a separate writing signed by an officer of Price Pump Co.

## 8. PATENTS

Seller agrees to assume the defense of any suit for infringement of any patents brought against Buyer to the extent of such suit charges infringement of an apparatus or product claim by Seller's product in and of itself, provided (i) said product is built entirely to Seller's design, (ii) Buyer notifies Seller in writing of the filing of such suit within ten (10) days after the service of process thereof, and (iii e ) Seller is given complete control of the defense of such suit, including the right to defend, settle and make changes in the product for the purpose of avoiding infringement of any process or method claims, unless infringement of such claims is the result of following specific instruction furnished by Seller.

## 9. EXTENT OF SUPPLY

Only products as listed in Seller's proposal are included in this agreement. It must not be assumed that Seller has included anything beyond same.

## 10. MANUFACTURING SOURCES

To maintain delivery schedules, Seller reserves the right to have all or any part of the Buyer's order manufactured at any of Sellers', sellers' licensees or sub contractors' plants, globally.

## 11. TERMS OF PAYMENT

Net 30 days from date of invoice.