



Enviro-Equipment Inc.
10120 Industrial Drive
Pineville NC 28134

Stock#: 961

Status: In stock, Tested

Dimensions: See Cut Sheet

Description: Rietschle C-DLR 500 Rotary Claw Air Compressor
Serial# 2814178, Date 3/08
40HP 3PH 3550RPM 230/460V 92/46 Amp TEFC Motor
353 CFM Max Flow, 29 PSIG Max Pressure
Also includes Kunkle Pressure Relief Valve.

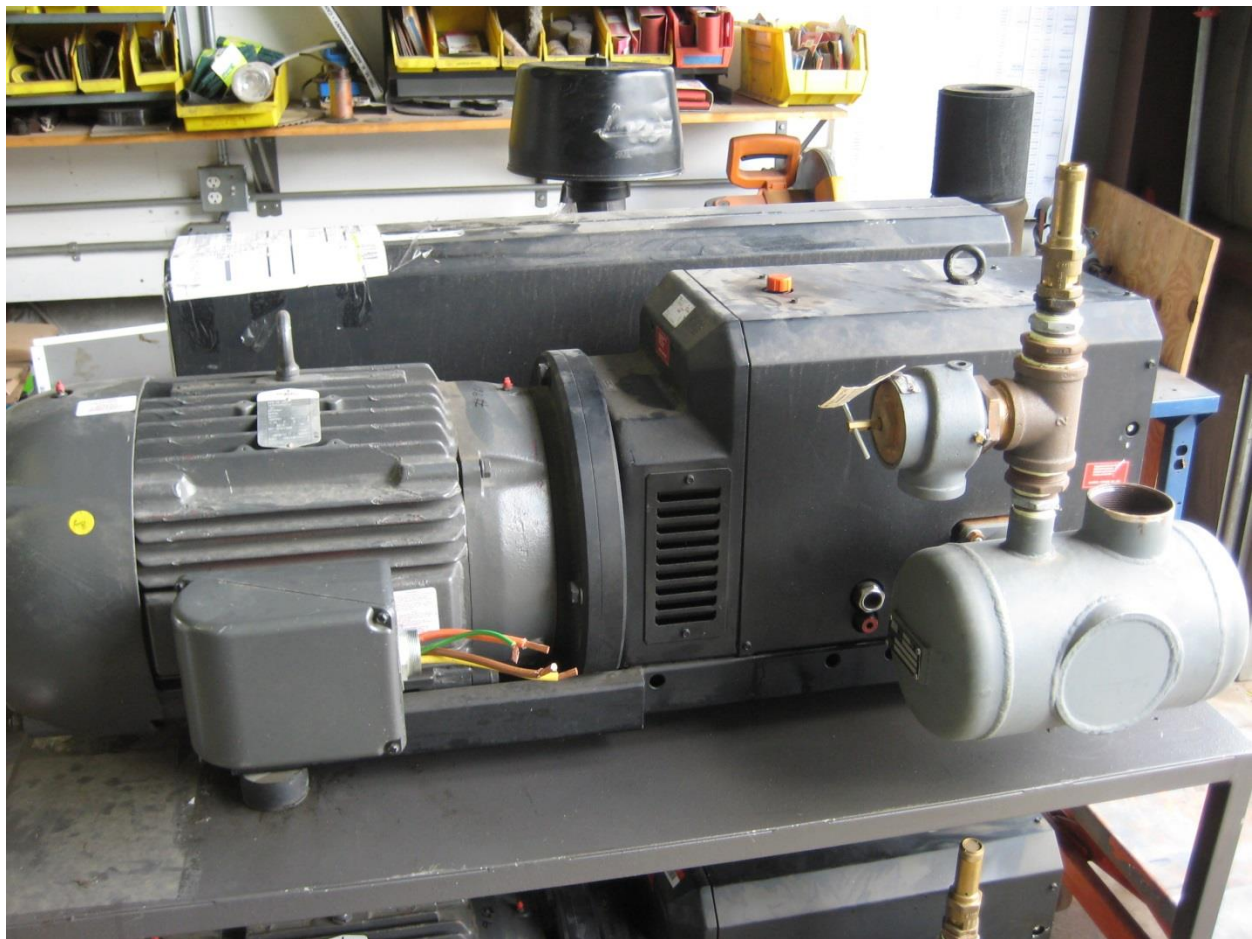



Compressors

Compresores

Compresseurs

Compressores

C-DLR

zephyr

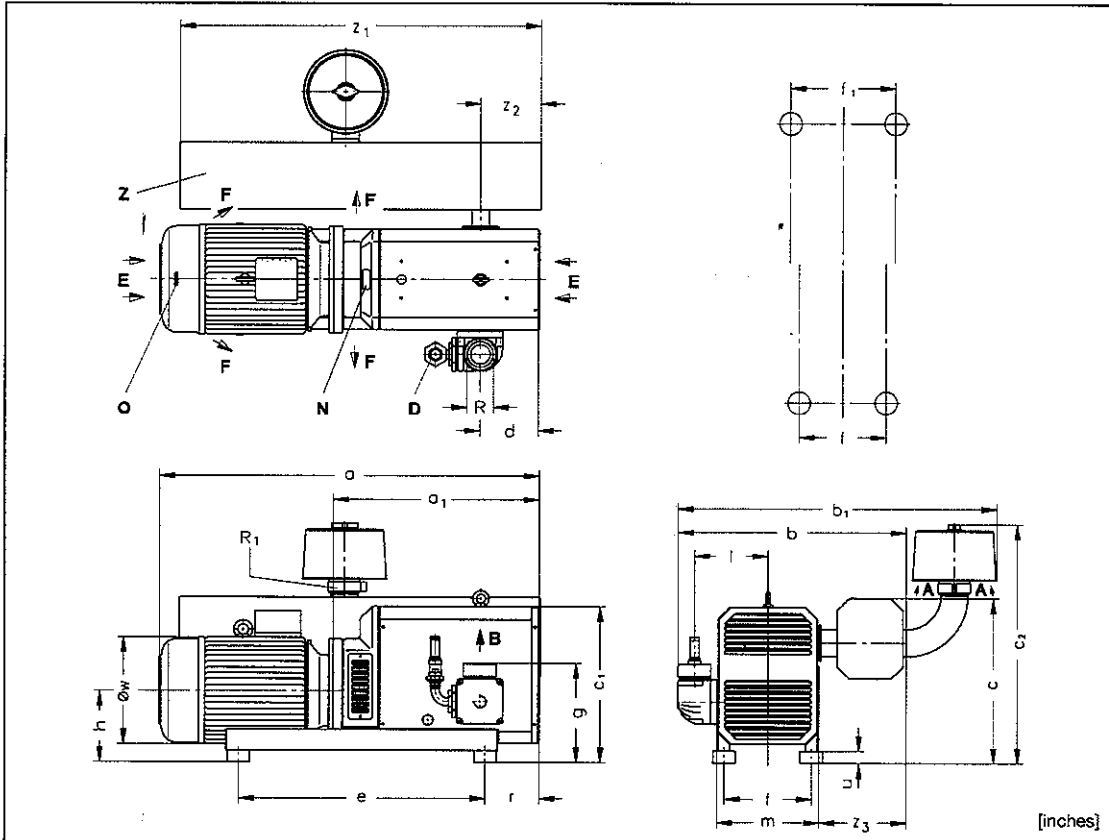

[inches]

A	Suction	Succión	Aspiration	Sucção
B	Pressure connection	Conexión presión	Raccord surpression	Conexão da pressão
D	Safety valve	Válvula seguridad	Clapet de sécurité	Válvula de segurança
E	Cooling air entry	Entrada aire refrigerante	Entrée air refroidissement	Entrada do ar refrigerante
F	Cooling air exit	Salida aire refrigerante	Sortie air refroidissement	Saída do ar refrigerante
N	Data plate	Placa fecha	Etiquette caractéristique	Placa da data
O	Rotation arrow	Dirección de rotación	Flèche sens rotation	Direção da rotação
Z	Inlet silencer	Silenciador entrada	Silencieux d'aspiration	Silenciador de entrada

C-DLR	250		300			400			500					
kw	50 Hz	7.5 11	7.5	11	15	11	15	18.5	22	15	18.5	22	30	
hp	60 Hz	15 20	15	20	25	20	25	30	-	-	30	-	40	
inches	a	50 Hz	36.26	40.67	36.26	40.67	40.67	47.36	47.36	47.36	49.76	47.36	49.76	54.09
		60 Hz	38.85	38.85	38.85	38.85	46.01	45.47	52.70	52.70	-	-	53.21	54.85
	a ₁	50 Hz	20.31	20.31	20.31	20.31	20.31	27.01	27.01	27.01	27.01	27.01	27.01	29.37
		60 Hz	22.28	22.28	22.28	22.28	22.62	28.90	29.31	29.31	-	-	29.82	29.82
	b / b ₁		28.43 / 38.03		28.43 / 38.03			29.29 / 38.03					30.08 / 42.40	
	c / c ₁ / c ₂		21.06 / 20.67 / 33.58		21.06 / 20.67 / 33.58			21.06 / 20.67 / 33.58					21.85 / 20.67 / 31.46	
	d		3.94		3.39			7.76					7.76	
	e		28.35		28.35			32.28				32.28	36.22	
	f		11.42		11.42			11.42				11.42	11.42	
	f ₁	50 Hz	-		-			-				-	13.78	
		60 Hz	-		13.78			13.78				-	13.78	
	g ₁		11.54		11.54			13.07				-	13.07	
	h		9.45		9.45			9.45				-	9.45	
	l		9.25		9.25			9.65				-	9.65	
	m		13.39		13.39			13.39				-	13.39	
	r / u		4.37 / 1.57		4.37 / 1.57			7.05 / 1.57				-	7.05 / 1.57	
	øw	50 Hz	9.69	12.28	9.69	12.28					12.28		14.17	
		60 Hz	11.47	11.47	11.47	11.47	15.30	11.47	15.30	-	-	15.30	-	16.88
	z ₁		39.37		39.37			39.37					47.24	
	z ₂ / z ₃		3.15 / 10.63		3.15 / 10.63			3.15 / 10.63					7.87 / 11.42	
	R / R ₁		2" NPT / BSP 2 1/4"		2" NPT / BSP 2 1/2"			3" NPT / BSP 2 1/2"					3" NPT / BSP 3"	

C-DLR 250

C-DLR 300

C-DLR 400

C-DLR 500

DA 881/2

2-2-2006

Gardner Denver Hanover Inc.

7222 Parkway Drive

HANOVER, MD 21076 USA

Phone +1 410 / 712 4100

Fax +1 410 / 712 4148

e-mail: sales.hanover@gardnerdenver.com

www.gd-elmoietschle.com

C-DLR	250			300			400				500				
cfm	138			177			227				294				
60 Hz	166			212			272				353				
psig	50 Hz	14.5	29.0	8.7	20.3	31.9	11.6	20.3	26.1	29.0	11.6	17.4	23.2	29.0	
60 Hz	23.2	31.9	14.5	26.1	31.9	14.5	23.2	29.0	-	-	20.3	-	29.0		
3 -	400/690V ± 10%														
50 Hz	208-230/460V ± 10%						230/460V ± 10%								
60 Hz	208-230/460V ± 10%						230/460V ± 10%								
kw	50 Hz	7.5	11	7.5	11	15	11	15	18.5	22	15	18.5	22	30	
hp	60 Hz	15	20	15	20	25	20	25	30	-	-	30	-	40	
A	60 Hz	39-37/18.5	51-46/23	39-37/18.5	51-46/23	62-58/29	51-46/23	62-58/29	68/34	-	-	68/34	-	92/46	
rpm	50 Hz	2850													
60 Hz	3450														
dB(A)	50 Hz	81			82			82				82			
60 Hz	85			85			85				85				
lbs	50 Hz	551	611	571	631	664	785	820	873	975	906	933	1010	1125	
60 Hz	643	641	663	661	801	816	956	100	-	-	1079	-	1183		
qt	0,75			0,75			0,75				0,75				
ZRZ	50			50			80				80				
ZDR	40			40			#				#				
ZPD	300			300			400				500				
ZMS / ZAD	#			#			#				#				

cfm	Capacity	Capacidad	Volume engendré	Capacidade
psig	Excess pressure	Exceso de presión	Surpression	Pressão excessiva
3 -	Motor version	Versión motor	Exécution moteur	Versão do motor
kw / hp	Motor rating	Datos motor	Puissance moteur	Potência do motor
A	Full load amperage	Amperaje de plena carga	Intensité absorbée	Amperagem da carga total
rpm	Speed	Velocidad	Vitesse rotation	Velocidade
dB(A)	Average noise level	Nível de ruido medio	Niveau sonore moyen	Nível médio de ruído
lbs	Weight	Peso	Poids	Peso
qt	Oil capacity (Gear)	Instrumentos capacidad aceite	Charge d'huile (Engrenage)	Engrenagem da capacidade do óleo
ZRZ	Accessories	Accesorios	Accessoires	Acessórios
ZDR	Non return leaf	Válvula retención	Clapet anti-retour	Válvula sem retorno
ZPD	Pressure regulating valve	Válvula reguladora de presión	Valve de réglage pression	Válvula de regulagem da pressão
ZMS	Pulsation silencer	Silenciador de pulsación	Absorbeur de pulsations	Silenciador de pulsação
ZAD	Motor starter	Arranque motor	Disjoncteur moteur	Arranque do motor
ZBZ	Soft starter	Soft starter	Démarrage progressif	Soft starter
	Sound box	Caja de sonido	Caïsson insonorisant	Canópia

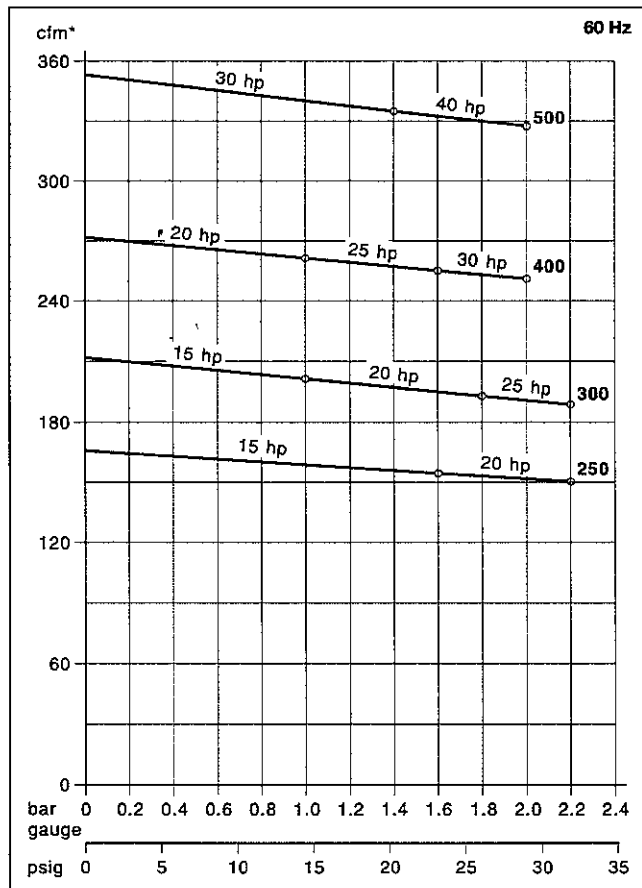
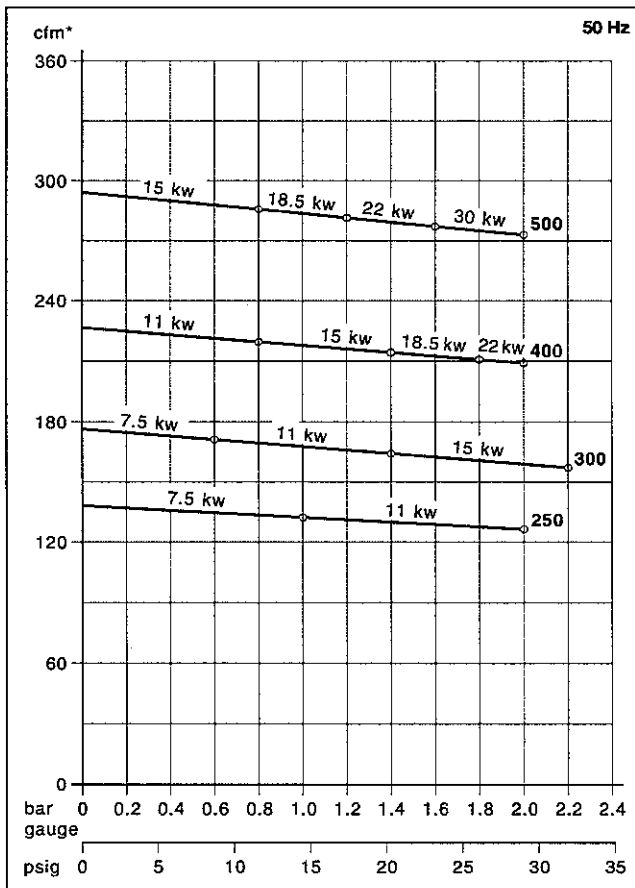

* Capacity refers to free air at 1 standard atmosphere and 20° C (68° F). / La capacidad se refiere al aire libre a 1 atmosfera estándar de presión y a 20° C (68° F) de temperatura. / Le débit est mesuré à l'atmosphère de 1 bar (abs.) à 20° C (68° F). / A capacidade refere-se ao ar livre a uma atmosfera padrão 1 e a 20° C (68° F).

Curves and tables refer to compressor at normal operating temperature. / Las curvas y las tablas se refieren al compresor a la temperatura normal de operación. / Les courbes et tableaux sont établies, compresseur à température de fonctionnement. / As curvas e tabelas referem-se ao compressor a temperatura normal de operação.

Technical information is subject to change without notice! / La información técnica está sujeta a cambios sin previo aviso! / Sous réserve de modification technique. / A informação técnica está sujeita a mudança sem aviso prévio!

The listed values for a, øw and full load amperage may vary because of different motor manufacturers. / Los valores listados para a, øw y para el amperaje de carga completa pueden variar para distintos fabricantes de motores. / Les dimensions a et øw ainsi que l'amperage peuvent différer des données indiquées ci-dessus, selon le fabricant du moteur. / Como variam os fabricantes de motores, poderá haver variação dos valores indicados para a, øw e para uma amperagem da carga total.

on request # on pedido # sur demande # a pedido