



Enviro-Equipment Inc.
10120 Industrial Drive
Pineville NC 28134

Serial#: EEI-1338

Status: In Stock, Tested

Dimensions: Skid is 106 x 37 x 83", Skid inside of crate is 115"x47"x95" and 2,400 pounds.

Description: 15HP SVE Skid Including Rotron EN909BG72WL 15HP 3PH XP Blower, Vacuum Gauges, Kunkle Vacuum Relief Valve with Inlet Screen, Exhaust Silencer, Knockout Tank with Integral Air Filter, Sight Glass and 3 Level Float Tree (LL, HL, HLA), Goulds 1ST1E5D4 Transfer Pump, Relay Logic Weatherproof Control Panel Wired 480V 3PH, Class 1 Div 2 Electrical (Outdoor Installation), All Mounted on Steel Skid



Environmental / Chemical Processing Blowers

EN 909 & CP 909

10.0 / 15.0 HP Sealed Regenerative w/Explosion-Proof Motor

ROTRON®

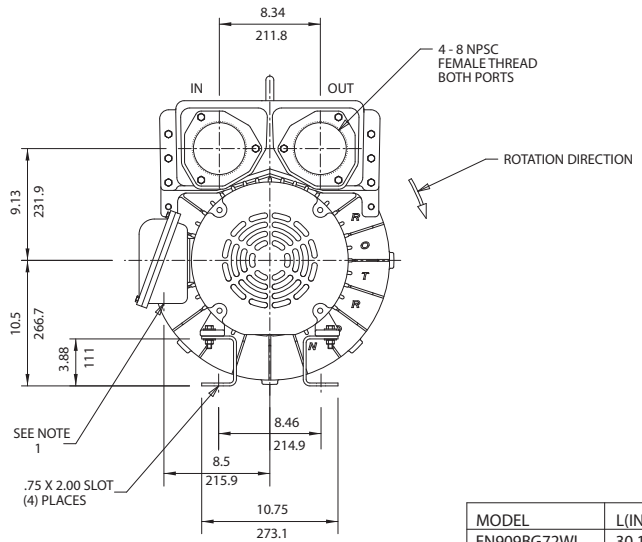
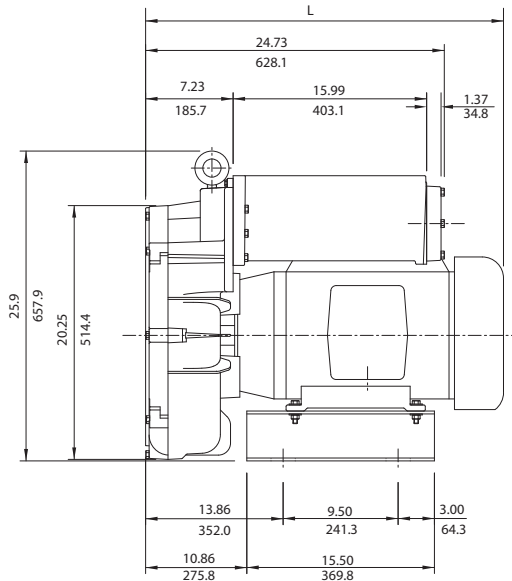

IN
MM

- NOTES
 1 TERMINAL BOX CONNECTOR HOLE 1 1/4" NPT FEMALE THREAD.
 2 DRAWING NOT TO SCALE, CONTACT FACTORY FOR SCALE CAD DRAWING.
 3 CONTACT FACTORY FOR BLOWER MODEL LENGTHS NOT SHOWN.

MODEL	L(IN/MM)
EN909BG72WL	30.17/766.3
EN909DB72WL	23.66/601.0

Specification	Units	Part/Model Number			
		EN909BG72WL 081741	EN909BG86WL 081736	EN909BD72WL 081743	CP909GA72WLR 038982
Motor Enclosure - Shaft Mtl.	-	15	15	10	15
Horsepower	-	Explosion-proof-CS	Explosion-proof-CS	Explosion-proof-CS	Chem XP-SS
Phase - Frequency	-	Three-60 hz	Three-60 hz	Three-60 hz	Three-60 hz
Voltage	AC	230/460	575	230/460	230/460
Motor Nameplate Amps	Amps (A)	36/18	14.4	24/12	36/18
Max. Blower Amps	Amps (A)	48/24	18	32/16	48/24
Inrush Amps	Amps (A)	240/120	100	234/117	240/120
Service Factor	-	2/2	2	2/1	2/2
Starter Size	-	1.0	1.0	1.0	1.0
Thermal Protection	-	Class B - Pilot Duty	Class B - Pilot Duty	Class B - Pilot Duty	Class B - Pilot Duty
XP Motor Class - Group	-	I-D, II-F&G	I-D, II-F&G	I-D, II-F&G	I-D, II-F&G
Shipping Weight	Lbs	524	524	504	524
	Kg	237.7	237.7	228.6	237.7

Voltage - ROTRON motors are designed to handle a broad range of world voltages and power supply variations. Our dual voltage 3 phase motors are factory tested and certified to operate on both: **208-230/415-460 VAC-3 ph-60 Hz** and **190-208/380-415 VAC-3 ph-50 Hz**. Our dual voltage 1 phase motors are factory tested and certified to operate on both: **104-115/208-230 VAC-1 ph-60 Hz** and **100-110/200-220 VAC-1 ph-50 Hz**. All voltages above can handle a ±10% voltage fluctuation. Special wound motors can be ordered for voltages outside our certified range.

Operating Temperatures - Maximum operating temperature: Motor winding temperature (winding rise plus ambient) should not exceed 140°C for Class F rated motors or 120°C for Class B rated motors. Blower outlet air temperature should not exceed 140°C (air temperature rise plus inlet temperature). Performance curve maximum pressure and suction points are based on a 40°C inlet and ambient temperature. Consult factory for inlet or ambient temperatures above 40°C.

Maximum Blower Amps - Corresponds to the performance point at which the motor or blower temperature rise with a 40°C inlet and/or ambient temperature reaches the maximum operating temperature.

XP Motor Class - Group - See Explosive Atmosphere Classification Chart in Section I

This document is for informational purposes only and should not be considered as a binding description of the products or their performance in all applications. The performance data on this page depicts typical performance under controlled laboratory conditions. AMETEK is not responsible for blowers driven beyond factory specified speed, temperature, pressure, flow or without proper alignment. Actual performance will vary depending on the operating environment and application. AMETEK products are not designed for and should not be used in medical life support applications. AMETEK reserves the right to revise its products without notification. The above characteristics represent standard products. For product designed to meet specific applications, contact AMETEK Technical & Industrial Products Sales department.

FEATURES

- Manufactured in the USA - ISO 9001 and NAFTA compliant
- Maximum flow: 615 SCFM
- Maximum pressure: 140 IWG
- Maximum vacuum: 112 IWG
- Standard motor: 15 HP, explosion-proof
- Cast aluminum blower housing, impeller, cover & manifold; cast iron flanges (threaded); teflon® lip seal
- UL & CSA approved motor with permanently sealed ball bearings for explosive gas atmospheres Class I Group D minimum
- Sealed blower assembly
- Quiet operation within OSHA standards

MOTOR OPTIONS

- International voltage & frequency (Hz)
- Chemical duty, high efficiency, inverter duty or industry-specific designs
- Various horsepower for application-specific needs

BLOWER OPTIONS

- Corrosion resistant surface treatments & sealing options
- Remote drive (motorless) models
- Slip-on or face flanges for application-specific needs

ACCESSORIES

- Flowmeters reading in SCFM
- Filters & moisture separators
- Pressure gauges, vacuum gauges, & relief valves
- Switches - air flow, pressure, vacuum, or temperature
- External mufflers for additional silencing
- Air knives (used on blow-off applications)
- Variable frequency drive package



Blower Performance at Standard Conditions

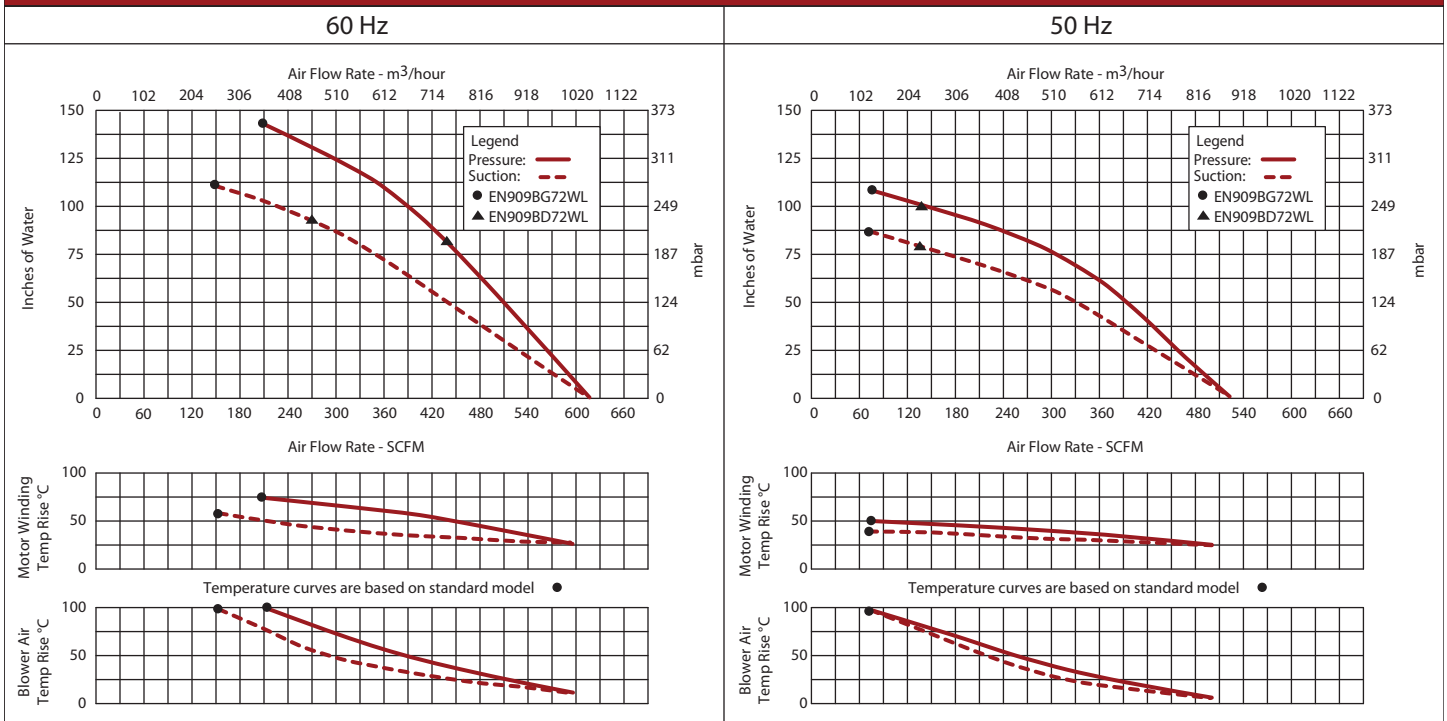

This document is for informational purposes only and should not be considered as a binding description of the products or their performance in all applications. The performance data on this page depicts typical performance under controlled laboratory conditions. AMETEK is not responsible for blowers driven beyond factory specified speed, temperature, pressure, flow or without proper alignment. Actual performance will vary depending on the operating environment and application. AMETEK products are not designed for and should not be used in medical life support applications. AMETEK reserves the right to revise its products without notification. The above characteristics represent standard products. For product designed to meet specific applications, contact AMETEK Technical & Industrial Products Sales department.