



Enviro-Equipment Inc.
10120 Industrial Drive
Pineville NC 28134

Stock#: EEI-1295

Status: in stock, tested

Dimensions: 273 pounds, 40" L x 24" W x 50" Tall

Description: Air Sparge Skid

Gast 2067-P118 Air Compressor, 17 CFM Max, 15 PSIG Max
1.5HP 1PH 115/230V Motor

Gast AJ126C Air Filter
Replacement Element AJ134C

3 Zone Air Sparge Manifold
Brass Ball Valves
0 – 15 PSIG Pressure Gauges
3 to 25 CFM Dwyer Rotameters
Quick Connect End Fittings

115V Control Panel with Blower HOA Switch, Run Hours,
Cycle Counter, 24 Hour Timer, Power Cord





GAST MANUFACTURING, INC.
 A Unit of IDEX Corporation
 Post Office Box 97
 Benton Harbor, Michigan
 Ph: 269/926-6171
 Fax: 269/925-8288

PART NUMBER:

STD470

REV.:

A

NOTES:

1. TECHNICAL DATA SUBJECT TO CHANGE WITHOUT NOTICE.
2. THIS PUMP MUST BE WIRED AND ENCLOSED IN CONFORMANCE WITH APPLICABLE LOCAL, STATE, NATIONAL OR INTERNATIONAL REGULATIONS.

SOUND LEVEL 86 dB(A) MAX.
 NORMAL AMBIENT +1 degC - +40 degC
 RELATIVE HUMIDITY 8% - 100% NON-CONDENSING
 ENVIRONMENT CLEAN DUST FREE

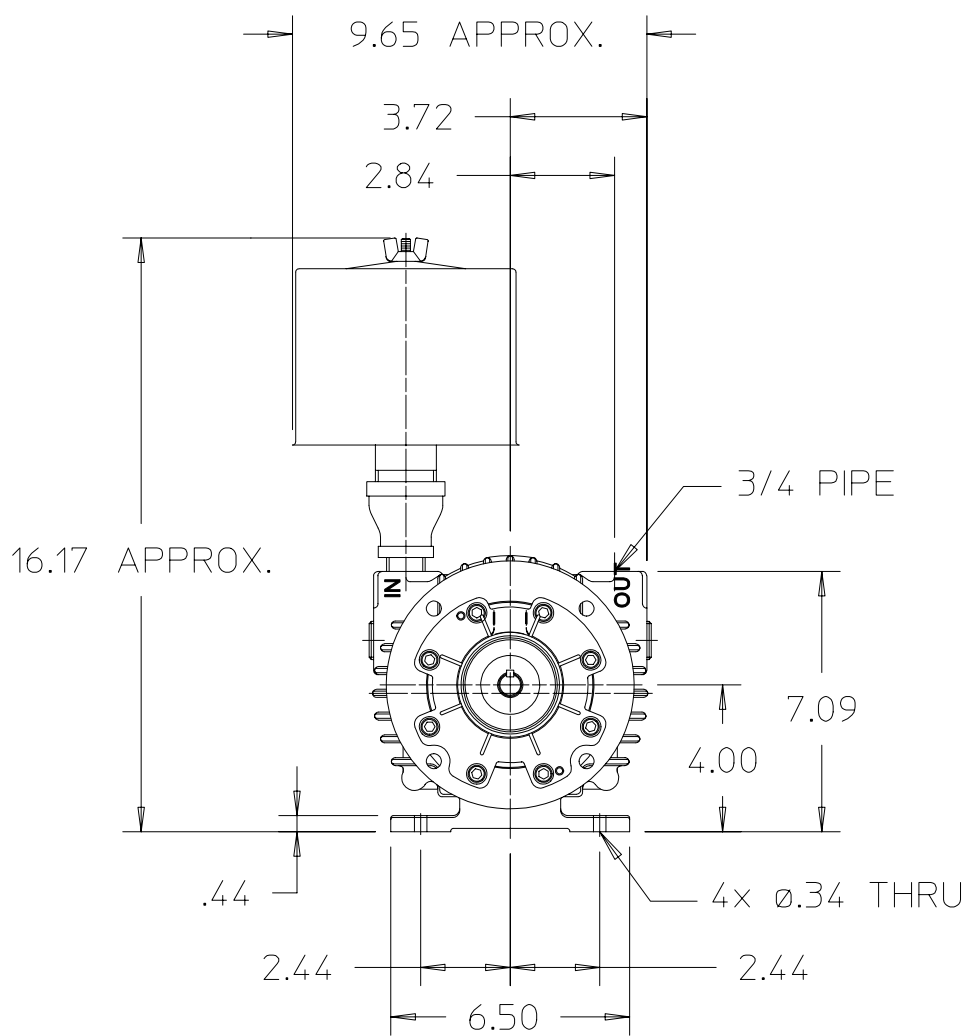
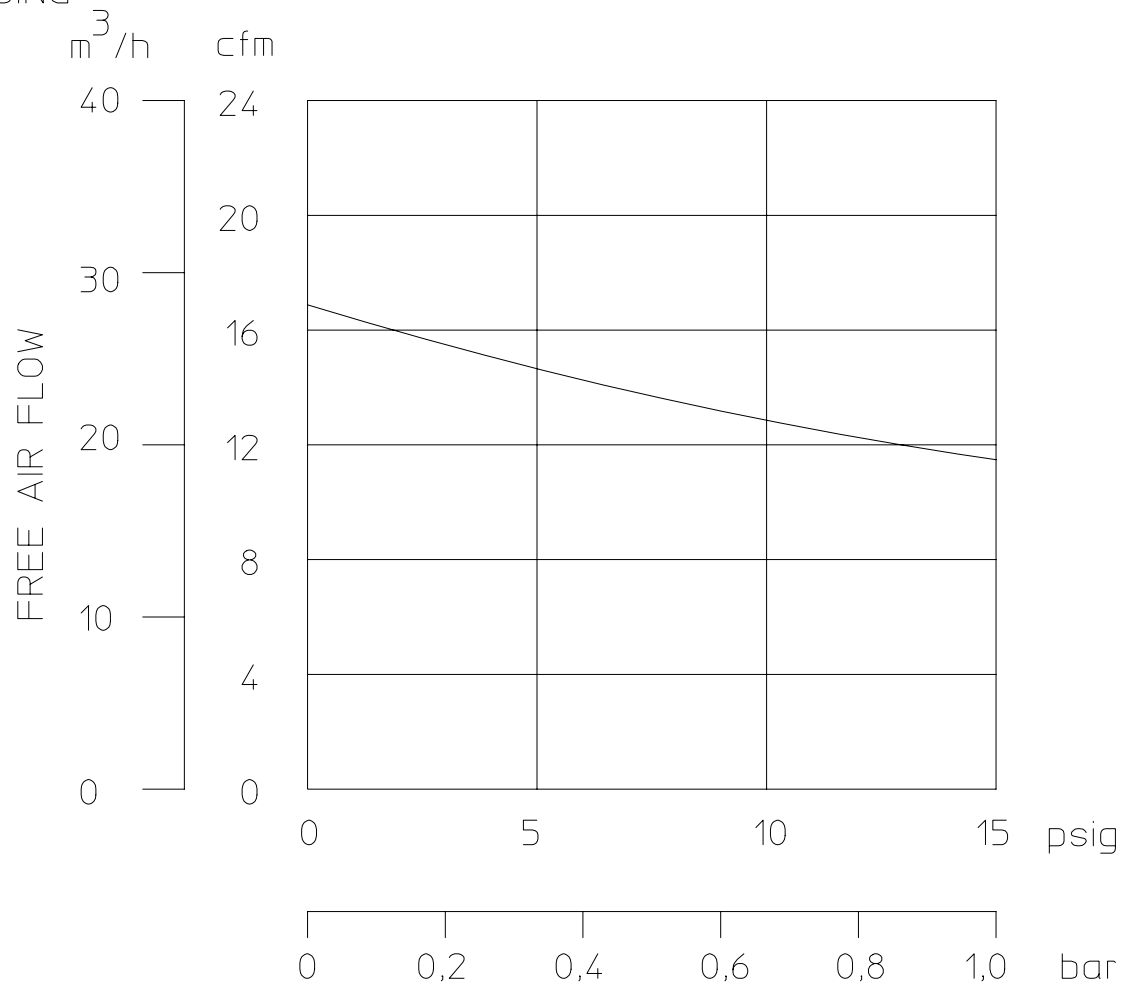

VIEW SHOWN LESS MOTOR

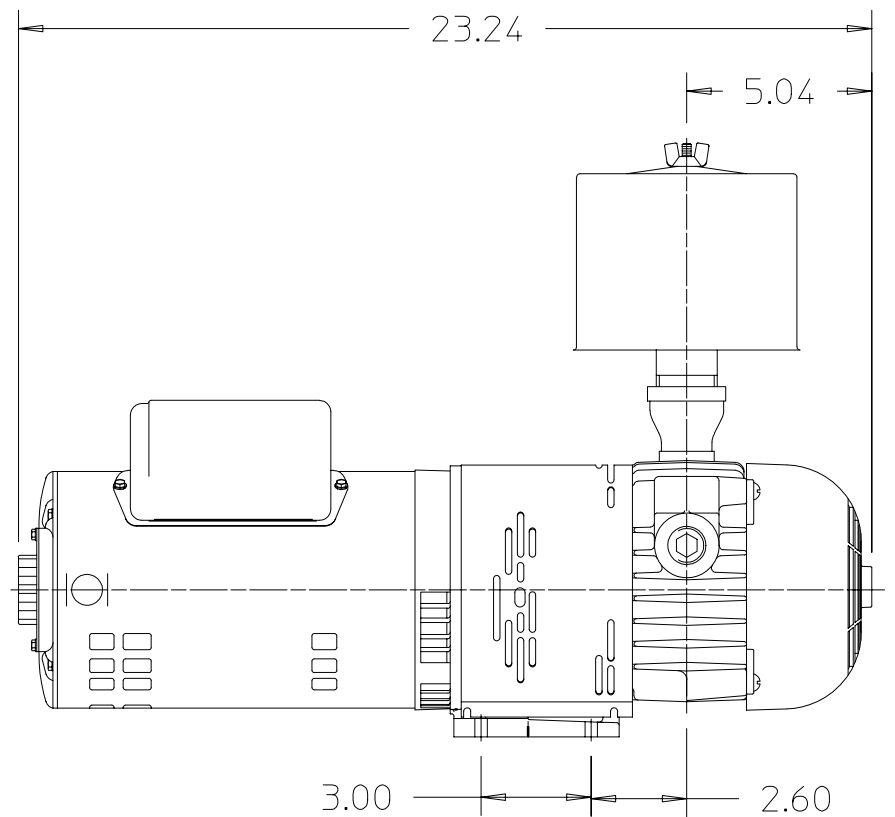

Product Specifications

Model Number	Motor	RPM		HP	kW	Net Wt.	
		60 cycle	50 cycle			lbs.	kg
2067-P118-G470X	115/230	1725	X	1.5	1,11	91	41,0