

G&L Series NPE/NPE-F

TABLE OF CONTENTS

NPE END SUCTION

NPE Product Line Numbering System	1
NPE Seal Chart (Part of Numbering System)	1
Parts List.....	2
Optional Components.....	2
Pictorial Breakdown of Pump	3
Impeller Chart Standard Impeller by Impeller Code.....	4
Impeller Chart by Motor Size at 3500 RPM	4
Motor Chart	5

NOTE:

For units built before September, 1997

The following upgrades are interchangeable.

- (1) Item 349 Guidevane O-Ring was upgraded from O-Ring to Square Seal Ring.
- (2) Pump Components have been upgraded from 304 SS to 316L SS.
- (3) Mechanical Seal upgrades as noted on page 1.
- (4) Pump Mounting location for motor adapter with foot to pump support are interchangeable.

NPE/NPE-F NUMBERING SYSTEM

1 ST 2 C 1 A 4 F

**SEAL VENT/FLUSH OPTION
MECHANICAL SEAL and O-RING**

4 = Pre-Engineered Standard
For Optional Mechanical Seal modify catalog order no. with Seal Code listed below.

21 Mechanical Seal (5/8" seal)						
Seal Code	Rotary	Stationary	Elastomers	Metal Parts	Part No.	Casing O-Ring
2	Carbon	Sil-Carbide	EPR	316 SS	10K18*	EPR
4			Viton		10K55***	Viton
5	Sil-Carbide		EPR		10K81	EPR
6			Viton		10K62**	Viton

Note: *Replaces obsolete 10K56 **Replaces obsolete 10K29 ***Replaces obsolete 10K46 and 10K24

Impeller Option Code . . . No Adder Required

For Optional Impeller Diameters modify catalog order no. with Impeller code listed below.

Select Optional Impeller Diameter from Pump Performance Curve.

Impeller Code	Pump Size		
	1 x 1 1/4-6	1 1/4 x 1 1/2-6	1 1/2 x 2-6
	Diameter	Diameter	Diameter
K		6 1/8	
G		5 15/16	5 3/8
H		5 1/2	5
A	6 1/8	5 1/4	4 3/4
B	5 3/4	5 1/16	4 5/8
C	5 3/16	4 7/8	4 3/8
D	4 3/4	4 5/8	4 1/16
E	4 7/16	4 1/4	3 5/8
F	4 1/16	3 7/8	

Note: Not recommended for operation beyond printed H-Q curve.

For critical application conditions, consult factory.

Note: Not all combinations of motor, impeller and seal options are available for every pump model. Please check with G&L on non-cataloged numbers.

Note: Impeller diameter is measured at the vane. The overall diameter of the shroud may be greater.

DRIVER

1 = 1PH, ODP 4 = 1 PH, TEFC 7 = 3 PH, XP
 2 = 3 PH, ODP 5 = 3 PH, TEFC 8 = 575 V, XP
 3 = 575 V, ODP 6 = 575 V, TEFC 0 = 1 PH, XP

HP RATING

C = 1/2 HP F = 1 1/2 HP J = 5 HP
 D = 3/4 HP G = 2 HP
 E = 1 HP H = 3 HP

DRIVER: HERTZ/POLE/RPM

1 = 60 HZ, 2 pole, 3500 RPM
 2 = 60 HZ, 4 pole, 1750 RPM
 3 = 60 HZ, 6 pole, 1150 RPM
 4 = 50 HZ, 2 pole, 2900 RPM
 5 = 50 HZ, 4 pole, 1450 RPM

MATERIAL

ST = Stainless Steel

PUMP SIZE

1 = 1 x 1 1/4 - 6 2 = 1 1/4 x 1 1/2 - 6 3 = 1 1/2 x 2 - 6

For Frame Mounted version, substitute the letters "FRM" in these positions.

NPE STANDARD REPAIR PARTS LIST

Item No.	Description	Materials of Construction	1ST 1 x 1¼	2ST 1¼ x 1½	3ST 1½ x 2	QTY.
100	Casing	AISI 316L SS	1L81	1L82	1L83	1
101	Impeller		See Impeller chart on page 4			1
108A	Motor adapter with foot*		1L80	1		
108B	Motor adapter less foot*		1L87			
123	Deflector	BUNA-N		5K7		1
184A	Seal housing standard	AISI 316L SS		1L79	1	
184B	Seal housing with seal flush		1L333			
240	Motor support	300 SS		4L320	1	
	Rubber channel	Rubber		9K188	1	
304	Impeller locknut	AISI 316 SS		13K286	1	
347	Guidevane	AISI 316L SS	3L23	3L24	3L25	1
349	Seal ring, guidevane	Viton standard	5K269	5K270		1
		EPR	5K273	5K274		
		BUNA	5K271	5K272		
370	Socket head screw, casing	AISI 410 SS	13L65			8
371	Bolts, motor	Steel/plated	13K252			4
383	Mechanical seal		See Mechanical Seal Chart on Page 1			1
408	Drain and vent plug, casing	AISI 316 SS		6L3		2
412B	O-ring, drain plugs	Viton, standard		5L99	2	
		EPR		5L80		
		BUNA		5L62		
513	O-ring, casing	Viton standard		5K206	1	
		EPR		5K193		
		BUNA		5K4		
575	Pipe Cap	304 SS		6K150	1	

* Flush access hole provided.

NOTE:
OPTIONAL SEAL FLUSH COMPONENTS

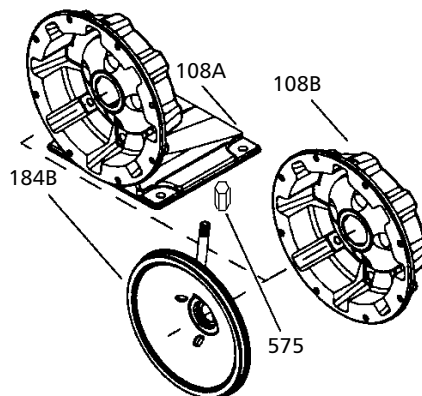

NOTE:

Close-coupled units using motors ½ – 1 HP (TEFC and ODP) will use footed motor adapter as standard.
 Close-coupled units using motors 1½ – 3 HP (TEFC and ODP) will use footless motor adapter as standard.
 Close-coupled units using motors 5 HP and all X-Proof will have a foot attached to the motor.

NOTE:

Frame mounted units (NPE-F) utilize the XS Power Frame and motor adapter less foot. For repair parts for the power frame refer to the XS-Power frame repair parts page in the parts section of your catalog. To order the power frame complete order item 14L61.

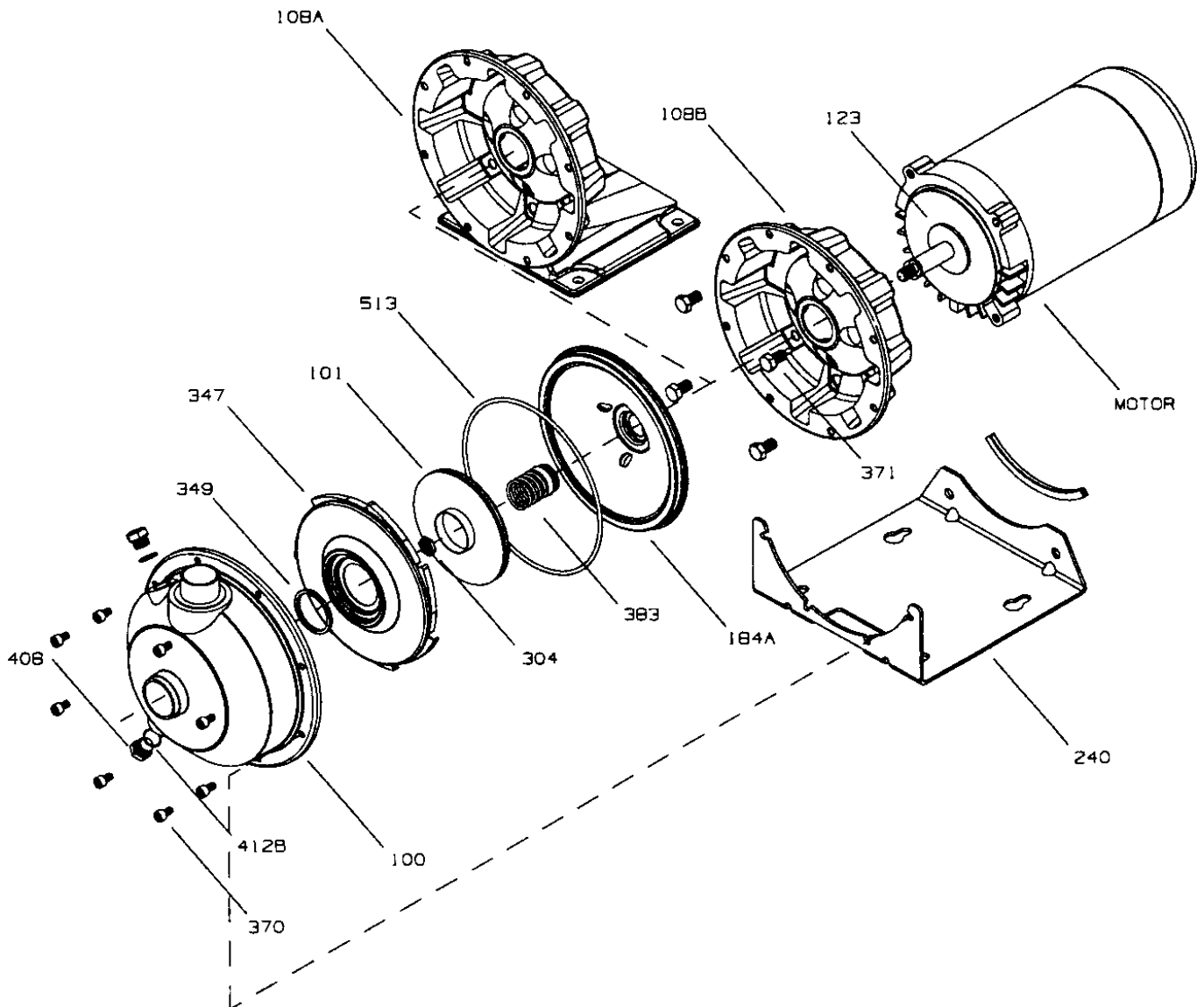

NPE STANDARD IMPELLERS

Impeller Code	Pump Size							
	1 x 1¼-6		1¼ x 1½-6		1½ x 2-6			
	Diameter	Part No.	Diameter	Part No.	Diameter	Part No.		
K			6⅛	2L885				
G			5 ¹⁵ / ₁₆	2L700			5 ³ / ₈	2L702
H			5½	2L699			5	2L701
A	6⅛	2L47	5¼	2L48	4¾	2L49		
B	5¾	2L44	5 ¹ / ₁₆	2L54	4 ⁵ / ₈	2L58		
C	5 ³ / ₁₆	2L46	4 ⁷ / ₈	2L53	4 ³ / ₈	2L57		
D	4¾	2L42	4 ⁵ / ₈	2L52	4 ¹ / ₁₆	2L56		
E	4 ⁷ / ₁₆	2L45	4¼	2L51	3 ³ / ₈	2L55		
F	4 ¹ / ₁₆	2L59	3 ⁷ / ₈	2L50				

NPE STANDARD IMPELLERS BY MOTOR SIZE AT 3500 RPM

For ODP/TEFC Units Built After September 1, 1997

HP	HP Code		1ST	2ST		3ST	
			ODP/TEFC	ODP/TEFC	ODP/TEFC		
½	C	Repair #	2L45				
		Dia.	4 ⁷ / ₁₆				
		Imp. Code	E				
¾	D	Repair #	2L42	2L50			
		Dia.	4¾	3 ⁷ / ₈			
		Imp. Code	D	F			
1	E	Repair #	2L46	2L51		2L55	
		Dia.	5 ³ / ₁₆	4¼		3 ³ / ₈	
		Imp. Code	C	E		E	
1½	F	Repair #	2L44	2L52		2L56	
		Dia.	5¾	4 ⁵ / ₈		4 ¹ / ₁₆	
		Imp. Code	B	D		D	
2	G	Repair #	2L47	2L53		2L57	
		Dia.	6⅛	4 ⁷ / ₈		4 ³ / ₈	
		Imp. Code	A	C		C	
3	H	Repair #	2L47	2L48		2L49	
		Dia.	6⅛	5¼		4¾	
		Imp. Code	A	A		A	
5	J	Repair #			2L700	2L885	2L702
		Dia.			5 ¹⁵ / ₁₆	6⅛	5 ³ / ₈
		Imp. Code			G	K	G

For Current Explosion Proof and All Units Built Before September 1, 1997

HP	HP Code		1ST		2ST		3ST		
			ODP	TEFC/EXP	ODP	TEFC/EXP	ODP	TEFC/EXP	
½	C	Repair #	2L45	2L59					
		Dia.	4 ⁷ / ₁₆	4 ¹ / ₁₆					
		Imp. Code	E	F					
¾	D	Repair #	2L42	2L45	2L50				
		Dia.	4¾	4 ⁷ / ₁₆	3 ⁷ / ₈				
		Imp. Code	D	E	F				
1	E	Repair #	2L46	2L42	2L51	2L50	2L55		
		Dia.	5 ³ / ₁₆	4¾	4¼	3 ⁷ / ₈	3 ³ / ₈		
		Imp. Code	C	D	E	F	E		
1½	F	Repair #	2L44	2L46	2L52	2L51	2L56	2L55	
		Dia.	5¾	5 ³ / ₁₆	4 ⁵ / ₈	4¼	4 ¹ / ₁₆	3 ³ / ₈	
		Imp. Code	B	C	D	E	D	E	
2	G	Repair #	2L47	2L44	2L53	2L52	2L57	2L56	
		Dia.	6⅛	5¾	4 ⁷ / ₈	4 ⁵ / ₈	4 ³ / ₈	4 ¹ / ₁₆	
		Imp. Code	A	B	C	D	C	D	
3	H	Repair #	2L47	2L47	2L48	2L54	2L49	2L58	
		Dia.	6⅛	6⅛	5¼	5 ¹ / ₁₆	4¾	4 ⁵ / ₈	
		Imp. Code	A	A	A	B	A	B	
5	J	Repair #			2L700	2L885			
		Dia.			5 ¹⁵ / ₁₆	6⅛			5 ³ / ₈
		Imp. Code			G	K			G

Note:** Max. Explosion Proof rating is 2 HP.

NPE CLOSE-COUPLED MOTORS

MODEL NPE 3500 RPM

HP	Single-Phase, 60 Hz, 115/230 V**, 56J Frame								
	Open, Drip-Proof ^①			Totally Enclosed, Fan Cooled			Explosion Proof		
	Order No.	Max. Amps	Wt. (lbs.)	Order No.	Max. Amps	Wt. (lbs.)	Order No.	Max. Amps	Wt. (lbs.)
1/2	E04853S	10.0/5.0	16	E04821	6.2/3.1	21	BBC04825	6.2/3.1	47
3/4	E05853S	14.0/7.0	19	E05821	8.8/4.4	24	BBC05825	8.8/4.4	41
1	E06853S	16.0/8.0	22	E06821	11.6/5.8	26	BBC06825	11.6/5.8	49
1 1/2	E07858S	21.4/10.7	31	E07821	16.2/8.1	35	BBC07825	16.2/8.1	56
2	E08854	26.8/13.4	36	E08821	20.8/10.4	39	BBC08825	20.8/10.4	60
3	E09854	14.0	40	E09821	11.89	44			
5	E10754	14.4	55						

Note:** 3 and 5 HP Single-Phase motors are 230 V only.

HP	Three-Phase, 60 Hz, 208-230/460 V, 56J Frame								
	Open, Drip-Proof ^①			Totally Enclosed, Fan Cooled			Explosion Proof		
	Order No.	Max. Amps	Wt. (lbs.)	Order No.	Max. Amps	Wt. (lbs.)	Order No.	Max. Amps	Wt. (lbs.)
1/2	E04873	2.6/1.3	19	E04876	1.9/.95	18	BBC04875	1.9/.95	27
3/4	E05873	3.4/1.7	19	E05876	2.3/1.15	21	BBC05875	2.3/1.15	30
1	E06873	4.2/2.1	22	E06876	3.2/1.6	21	BBC06875	3.2/1.6	30
1 1/2	E07878	5.8/2.9	25	E07876	4.8/2.4	27	BBC07875	4.8/2.4	37
2	E08874	6.9/3.3	39	E08876	5.4/2.7	33	BBC08875	5.4/2.7	44
3	E09874	7.2/3.6	31	E09876	7.6/3.8	37			
5	E10774	7.2/14.4	50	E10876	6.2/12.4	48			

① For vertical mounting order motor canopy separately - 9K272 for 1/2, 3/4 and 1 HP single phase or 9K273 for all other ODP motors.

MODEL NPE 1750 RPM

HP	Single-Phase, 60 HZ, 115/230 V, 56J Frame								
	Open, Drip-Proof ^①			Totally Enclosed, Fan Cooled			Explosion Proof		
	Order No.	Max. Amps	Wt. (lbs.)	Order No.	Max. Amps	Wt. (lbs.)	Order No.	Max. Amps	Wt. (lbs.)
1/2	E04811	8.6/4.3	19	E04812	8.0/4.0	20	BBC04815	8.0/4.0	45

HP	Three-Phase, 60 HZ, 208-230/460 V, 56J Frame								
	Open, Drip-Proof ^①			Totally Enclosed, Fan Cooled			Explosion Proof		
	Order No.	Max. Amps	Wt. (lbs.)	Order No.	Max. Amps	Wt. (lbs.)	Order No.	Max. Amps	Wt. (lbs.)
1/2	E04831	3.76/4.0/2.0	20	E04832	1.77/1.6/.8	20	BBC04835	1.77/1.6/.8	45

Note: Explosion Proof Motors are class 1 and 2, Group D



Goulds Pumps is a brand of ITT Water Technology, Inc.
- a subsidiary of ITT Industries, Inc.

Goulds Pumps, G&L and the ITT Engineered Blocks Symbol
are registered trademarks and tradenames of ITT Industries.

Printed in U.S.A.

SPECIFICATIONS ARE SUBJECT TO CHANGE WITHOUT NOTICE.
www.goulds.com

Goulds Pumps

