



Enviro-Equipment, Inc. Remediation Division

Stock # 1618

Used Rotron EN505AX72ML, 2HP, 230/460 V, 3-Phase XP Blower.

SPECIFICATIONS

Dimensions: 15.18" x 11.7" x 14.43"

Weight: 84 Lbs. (Blower Only)

Brand: Rotron

Model: EN505AX72ML

Max Pressure: 62" H2O

Max Vacuum: 60" H2O

Max Air Flow: 110 SCFM

Motor:

Explosion Proof: Yes

Horsepower: 2.00 HP

Phase: 3

Voltage: 230/460

RPM: 3450

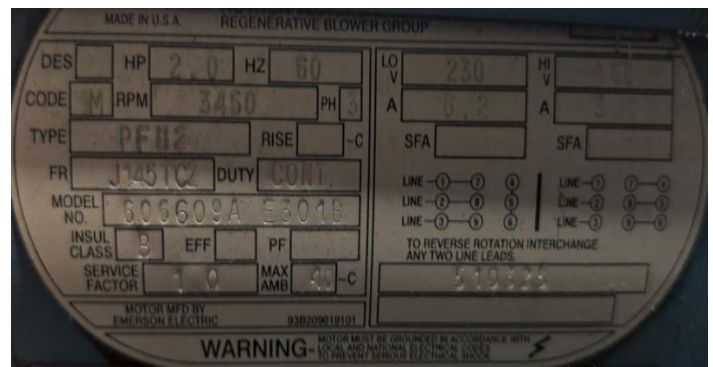

ADDITIONAL PICTURES BELOW



Enviro-Equipment, Inc.

Remediation Division

2.0 / 2.5 HP Sealed Regenerative w/Explosion-Proof Motor

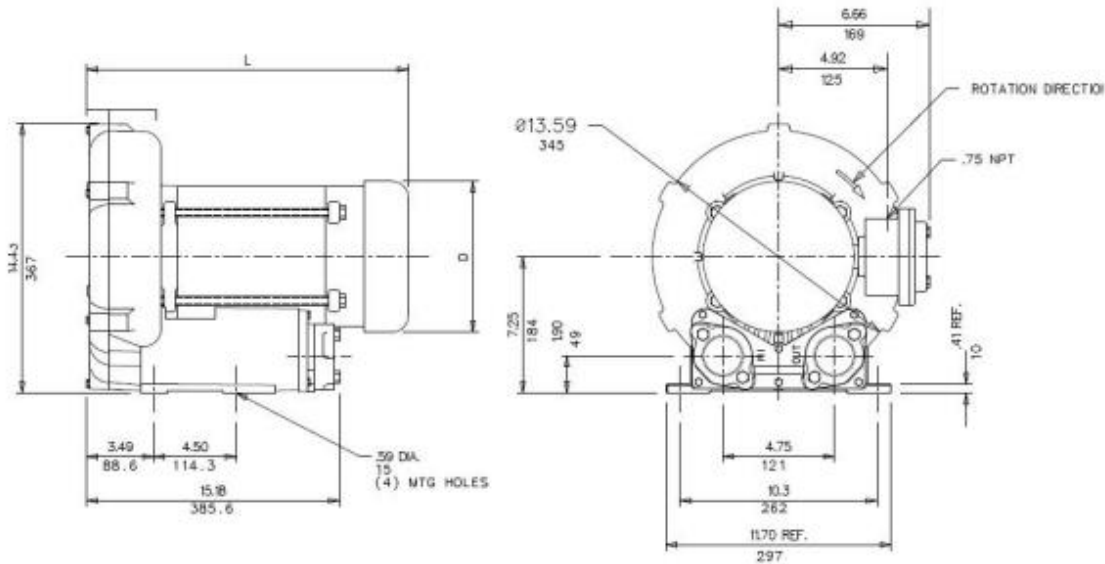

IN
MM

- NOTES
1. TERMINAL BOX CONNECTOR HOLE 3/4" NPT.
 2. DRAWING NOT TO SCALE, CONTACT FACTORY FOR SCALE CAD DRAWING.
 3. CONTACT FACTORY FOR BLOWER MODEL LENGTHS NOT SHOWN.

Specification	Units	Part/Model Number			
		EN505AX58ML 038177	EN505AX72ML 038178	CP505FS58MLR 080655	CP505FS72MLR 038962
Motor Enclosure - Shaft Mt.	-	Explosion-proof-CS	Explosion-proof-CS	CHEM XP-SS	CHEM XP-SS
Horsepower	-	2.0	2.0	2.0	2.0
Phase - Frequency	-	Single-60 hz	Three-60 hz	Single-60 hz	Three-60 hz
Voltage	AC	115/230	230/460	115/230	230/460
Motor Nameplate Amps	Amps (A)	22/11	5.8/2.9	22/11	5.8/2.9
Max. Blower Amps	Amps (A)	24/12	6.4/3.2	24/12	6.4/3.2
Locked Rotor Amps	Amps (A)	112/56	56/28	112/56	56/28
Service Factor	-	1/0	0/0	1/0	0/0
Starter Size	-	1.0	1.0	1.0	1.0
Thermal Protection	-	Class B - Pilot Duty	Class B - Pilot Duty	Class B - Pilot Duty	Class B - Pilot Duty
XP Motor Class - Group	-	I-D, II-F&G	I-D, II-F&G	I-D, II-F&G	I-D, II-F&G
Shipping Weight	Lbs	92	84	92	84
	Kg	41.7	38.1	41.7	38.1

Voltage - ROTRON motors are designed to handle a broad range of world voltages and power supply variations. Our dual voltage 3 phase motors are factory tested and certified to operate on both: 208-230/415-460 VAC-3 ph-60 Hz and 190-208/380-415 VAC-3 ph-50 Hz. Our dual voltage 1 phase motors are factory tested and certified to operate on both: 104-115/208-230 VAC-1 ph-60 Hz and 100-110/200-220 VAC-1 ph-50 Hz. All voltages above can handle a ±10% voltage fluctuation. Special wound motors can be ordered for voltages outside our certified range.

Operating Temperatures - Maximum operating temperature: Motor winding temperature (winding rise plus ambient) should not exceed 140°C for Class F rated motors or 120°C for Class B rated motors. Blower outlet air temperature should not exceed 140°C (air temperature rise plus inlet temperature). Performance curve maximum pressure and suction points are based on a 40°C inlet and ambient temperature. Consult factory for inlet or ambient temperatures above 40°C.

Maximum Blower Amps - Corresponds to the performance point at which the motor or blower temperature rise with a 40°C inlet and/or ambient temperature reaches the maximum operating temperature.

XP Motor Class - Group - See Explosive Atmosphere Classification Chart in Section I

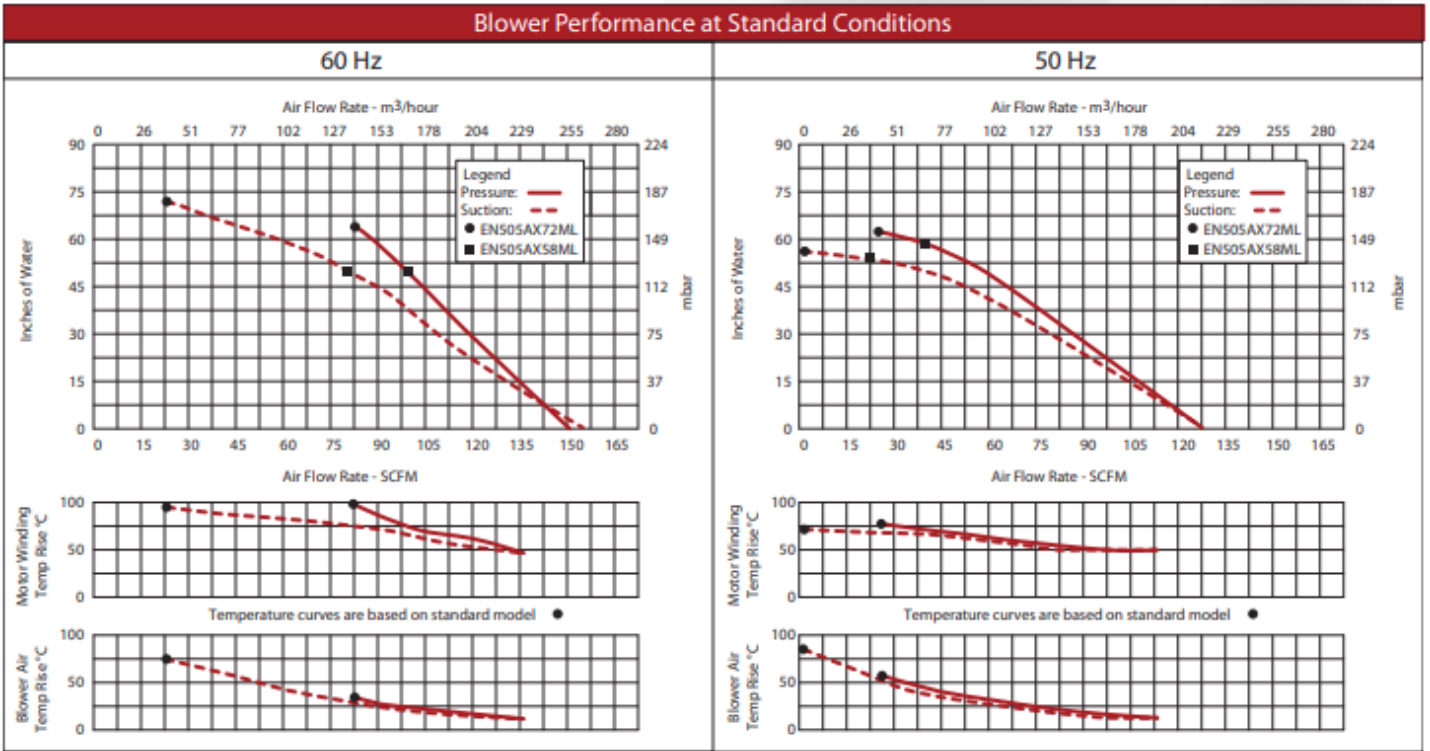

This document is for informational purposes only and should not be considered as a binding description of the products or their performance in all applications. The performance data on this page depicts typical performance under controlled laboratory conditions. AMETEK is not responsible for blowers driven beyond factory specified speed, temperature, pressure, flow or without proper alignment. Actual performance will vary depending on the operating environment and application. AMETEK products are not designed for and should not be used in medical life support applications. AMETEK reserves the right to revise its products without notification. The above characteristics represent standard products. For product designed to meet specific applications, contact AMETEK Technical & Industrial Products Sales department.

