



Stock # 1024

Used Rotron DR101BX9M, 0.33 HP, 115/230V, 1PH, TEFC Blower

SPECIFICATIONS

Dimensions: 11.1" x 7.41" x 8.25"

Weight: 31-Lbs. (Blower Only)

Brand: Rotron
Model: DR101BX9M

Max Pressure: 32" H2O
Max Vacuum: 28.5" H2O
Max Air Flow: 29 SCFM

Motor: Baldor
Explosion Proof: No
Horsepower: 0.33
Phase: 1
Voltage: 115/230
RPM: 3450

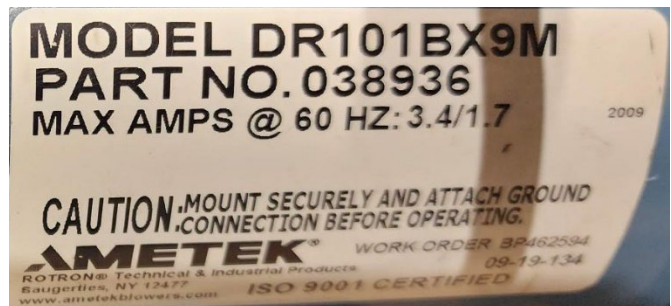
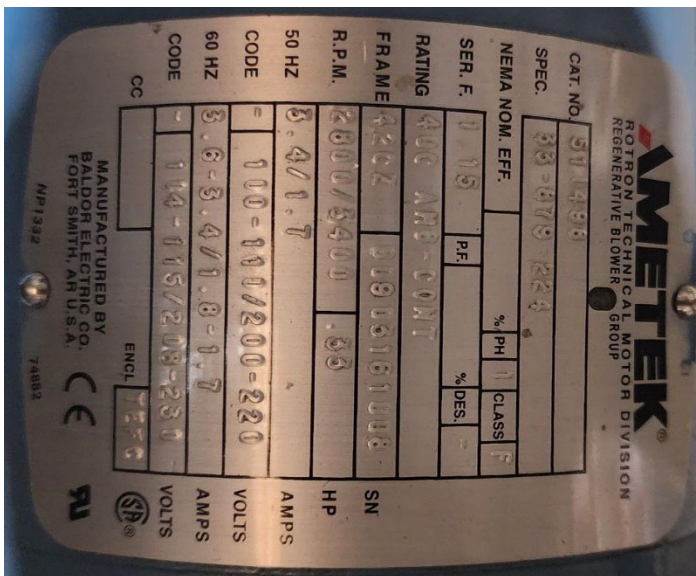



FEATURES

- Manufactured in the USA – ISO 9001 compliant
- CE compliant – Declaration of Conformity on file
- Maximum flow: 29 SCFM
- Maximum pressure: 32 IWG
- Maximum vacuum: 2.1" IHG (28.5 IWG)
- Standard motor: 0.33 HP, TEFC
- Cast aluminum blower housing, diecast impeller & cover; cast iron flanges (threaded)
- UL & CSA approved motor with permanently sealed ball bearings
- Inlet & outlet internal muffling
- Quiet operation within OSHA standards

MOTOR OPTIONS

- International voltage & frequency (Hz)
- Chemical duty, high efficiency, inverter duty or industry-specific designs
- Various horsepower for application-specific needs

BLOWER OPTIONS

- Corrosion resistant surface treatments & sealing options
- Remote drive (motorless) models
- Slip-on or face flanges for application-specific needs

ACCESSORIES (See Catalog Accessory Section)

- Flowmeters reading in SCFM
- Filters & moisture separators
- Pressure gauges, vacuum gauges & relief valves
- Switches – air flow, pressure, vacuum or temperature
- External mufflers for additional silencing
- Air knives (used on blow-off applications)
- Variable frequency drive package

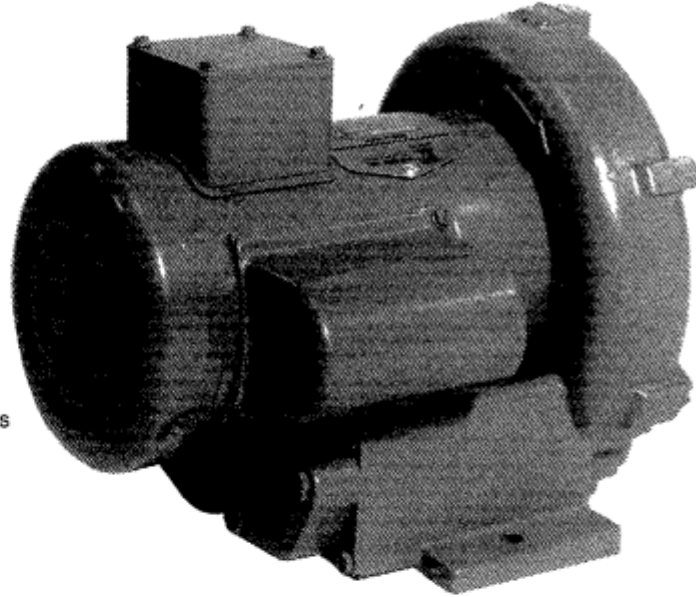

BLOWER PERFORMANCE AT STANDARD CONDITIONS

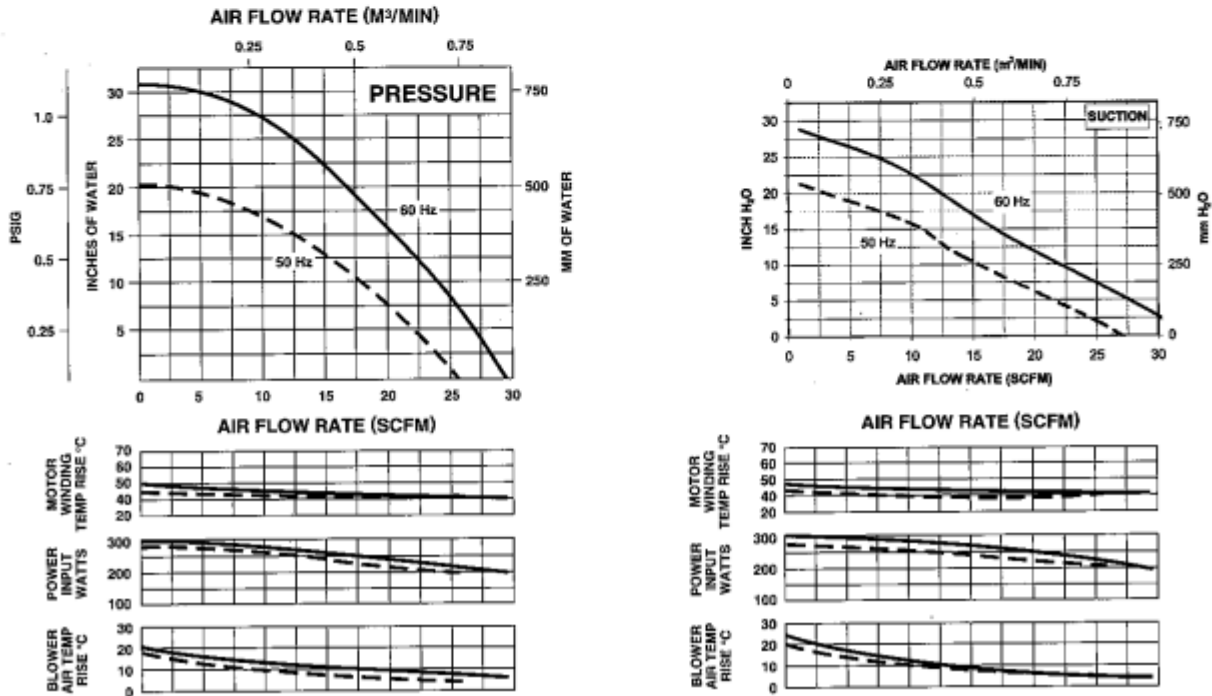

Rev. 2/04



Enviro-Equipment, Inc.

Remediation Division

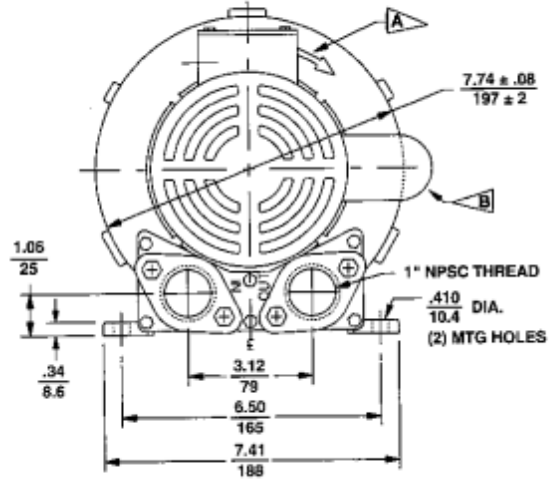
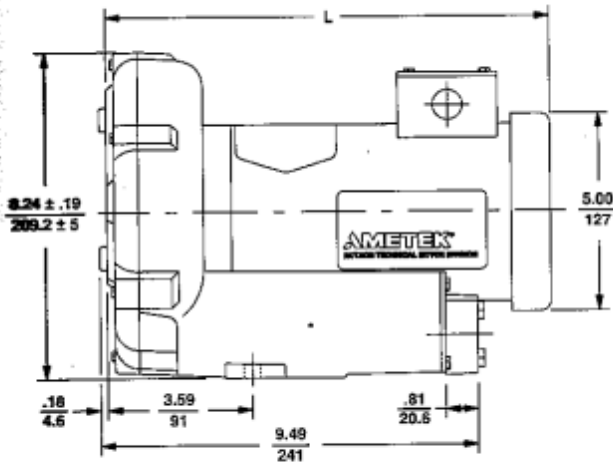

MODEL	L (IN/MM)
DR101DC9M	9.43 / 239.5
DR101BX9M	11.1 / 281.9
DR101BX72M	11.1 / 281.9
DR101BX86M	11.1 / 281.9

DIMENSIONS: $\frac{IN}{MM}$
 TOLERANCES: $.XX \pm \frac{.08}{2}$
 UNLESS OTHERWISE NOTED

- A** .87 INCH DIAMETER CONNECTOR HOLE
- B** CAPACITOR LOCATION ON SINGLE PHASE MOTORS

SPECIFICATIONS

MODEL	DR101BX9M	DR101BX72M	DR101BX86M	CP101FB91MLR
Part No.	038936	038937	038938	038225
Motor Enclosure – Shaft Material	TEFC – CS	TEFC – CS	TEFC – CS	ChemTEFC – SS
Horsepower	0.33	0.33	0.33	Same as DR101BX72M – 038937 except add Chemical Processing (CP) features from catalog inside front cover
Voltage ¹	115/230	200-230/460	575	
Phase – Frequency ¹	Single - 60 Hz	Three - 60 Hz	Three - 60 Hz	
Insulation Class ²	F	F	F	
NEMA Rated Motor Amps	4.2/2.1	1.3-1.2/0.6	0.6	
Service Factor	1.35	1.25	1.25	
Locked Rotor Amps	16.4/8.2	6.4-5.8/2.9	4.2	
Max. Blower Amps ³	3.8/1.9	1.30/.65	0.4	
Recommended NEMA Starter Size	00/00	00-00/00	00	
Shipping Weight	31 lb (14 kg)	31 lb (14 kg)	58 lb (26 kg)	

- ¹ Rotron motors are designed to handle a broad range of world voltages and power supply variations. Our dual voltage 3 phase motors are factory tested and certified to operate on both: **208-230/415-460 VAC-3 ph-60 Hz** and **190-208/380-415 VAC-3 ph-50 Hz**. Our dual voltage 1 phase motors are factory tested and certified to operate on both: **104-115/208-230 VAC-1 ph-60 Hz** and **100-110/200-220 VAC-1 ph-50 Hz**. All voltages above can handle a $\pm 10\%$ voltage fluctuation. Special wound motors can be ordered for voltages outside our certified range.
- ² Maximum operating temperature: Motor winding temperature (winding rise plus ambient) should not exceed 140°C for Class F rated motors or 120°C for Class B rated motors. Blower outlet air temperature should not exceed 140°C (air temperature rise plus inlet temperature). Performance curve maximum pressure and suction points are based on a 40°C inlet and ambient temperature. Consult factory for inlet or ambient temperatures above 40°C.
- ³ Maximum blower amps corresponds to the performance point at which the motor or blower temperature rise with a 40°C inlet and/or ambient temperature reaches the maximum operating temperature.