

## DR 656 & CP 656

3.0 / 3.5 HP Regenerative Blower

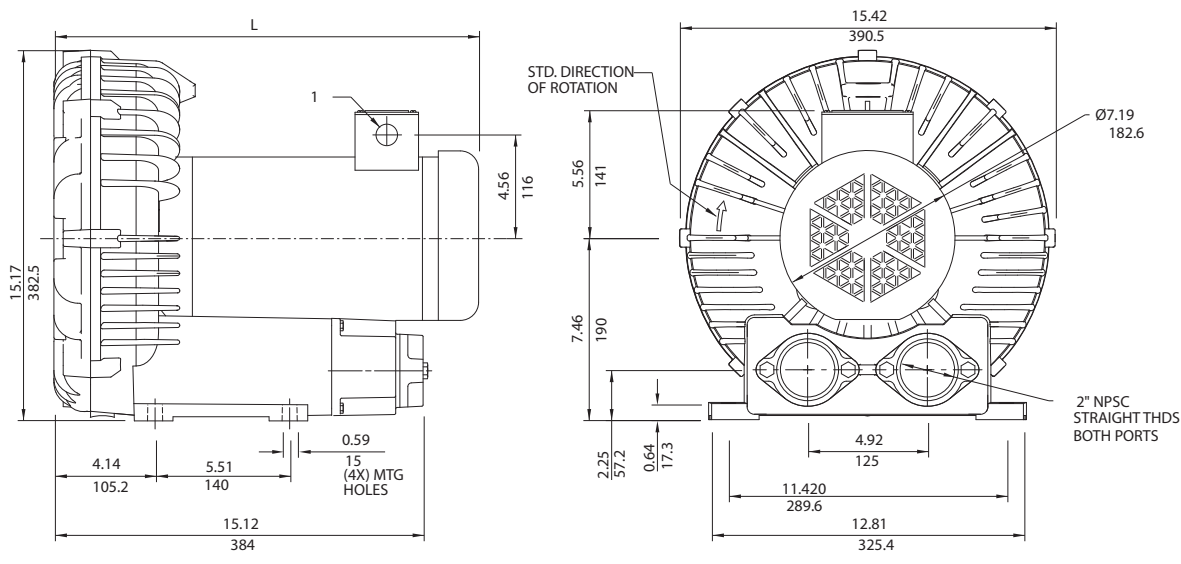

NOTES

- 1) TERMINAL BOX CONNECTOR HOLE .88 (22) DIA.
- 2) DRAWING NOT TO SCALE, CONTACT FACTORY FOR SCALE CAD DRAWING.
- 3) CONTACT FACTORY FOR BLOWER MODEL LENGTHS NOT SHOWN.

MODEL	L (IN/MM)
DR656CK72X	17.50/444.5
DR656K72X	16.00/406.4

Specification	Units	Part/ Model Number					
		DR656CK72X	DR656CK86X	DR656CK5X	DR656K72X	DR656K58X	CP656CR72XLR
Motor Enclosure - Shaft Mtl.	-	TEFC - CS	TEFC - CS	TEFC-CS	TEFC - CS	TEFC - CS	CHEM TEFC-SS
Horsepower	-	3.5	3.5	3.5	3.0	3.0	3.5
Voltage	AC	230/460	575	230	230/460	115/230	230/460
Phase - Frequency	-	Three - 60 Hz	Three - 60 Hz	Single - 60 Hz	Three - 60 Hz	Single - 60 Hz	Three - 60 Hz
Insulation Class	-	F	F	F	F	F	F
NEMA Rated Motor Amps	Amps (A)	10.0/5.0	4.0	18	7.4/3.7	29/14.5	10.0/5.0
Service Factor	-	1.15	1.0	1.15	1.15	1.0	1.15
Max. Blower Amps	Amps (A)	11.4/5.7	5.2	18	9/4.5	27.8/13.9	11.4/5.7
Locked Rotor Amps	Amps (A)	94/47	80	115	54/27	172/86	94/47
NEMA Starter Size	-	1/0	0	1	0/0	1.5/1.0	1/0
Shipping Weight	Lbs Kg	110 49.9	114 51.7	101 45.8	103 46.7	114 51.7	110 49.9

**Voltage** - ROTRON motors are designed to handle a broad range of world voltages and power supply variations. Our dual voltage 3 phase motors are factory tested and certified to operate on both: **208-230/415-460 VAC-3 ph-60 Hz** and **190-208/380-415 VAC-3 ph-50 Hz**. Our dual voltage 1 phase motors are factory tested and certified to operate on both: **104-115/208-230 VAC-1 ph-60 Hz** and **100-110/200-220 VAC-1 ph-50 Hz**. All voltages above can handle a ±10% voltage fluctuation. Special wound motors can be ordered for voltages outside our certified range.

**Operating Temperatures** - Maximum operating temperature: Motor winding temperature (winding rise plus ambient) should not exceed 140°C for Class F rated motors or 120°C for Class B rated motors. Blower outlet air temperature should not exceed 140°C (air temperature rise plus inlet temperature). Performance curve maximum pressure and suction points are based on a 40°C inlet and ambient temperature. Consult factory for inlet or ambient temperatures above 40°C.

**Maximum Blower Amps** - Corresponds to the performance point at which the motor or blower temperature rise with a 40°C inlet and/or ambient temperature reaches the maximum operating temperature.

*This document is for informational purposes only and should not be considered as a binding description of the products or their performance in all applications. The performance data on this page depicts typical performance under controlled laboratory conditions. AMETEK is not responsible for blowers driven beyond factory specified speed, temperature, pressure, flow or without proper alignment. Actual performance will vary depending on the operating environment and application. AMETEK products are not designed for and should not be used in medical life support applications. AMETEK reserves the right to revise its products without notification. The above characteristics represent standard products. For product designed to meet specific applications, contact AMETEK Technical & Industrial Products Sales department.*

## DR 656 & CP 656

3.0 / 3.5 HP Regenerative Blower

### FEATURES

- Manufactured in the USA - ISO 9001 and NAFTA compliant
- CE compliant - Declaration of Conformity on file
- Maximum flow: 210 SCFM
- Maximum pressure: 110 IWG
- Maximum vacuum: 89 IWG
- Standard motor: 4.0 HP, TEFC
- Cast aluminum blower housing, impeller & cover; cast iron muffler extension & flanges (threaded)
- UL & CSA approved motor with permanently sealed ball bearings
- Inlet & outlet internal muffling
- Quiet operation within OSHA standards

### MOTOR OPTIONS

- International voltage & frequency (Hz)
- Chemical duty, high efficiency, inverter duty or industry-specific designs
- Various horsepower for application-specific needs

### BLOWER OPTIONS

- Corrosion resistant surface treatments & sealing options
- Remote drive (motorless) models
- Slip-on or face flanges for application-specific needs
- Cast iron cover for additional noise resonance

### ACCESSORIES

- Flowmeters reading in SCFM
- Filters & moisture separators
- Pressure gauges, vacuum gauges, & relief valves
- Switches - air flow, pressure, vacuum, or temperature
- External mufflers for additional silencing
- Air knives (used on blow-off applications)



### Blower Performance at Standard Conditions

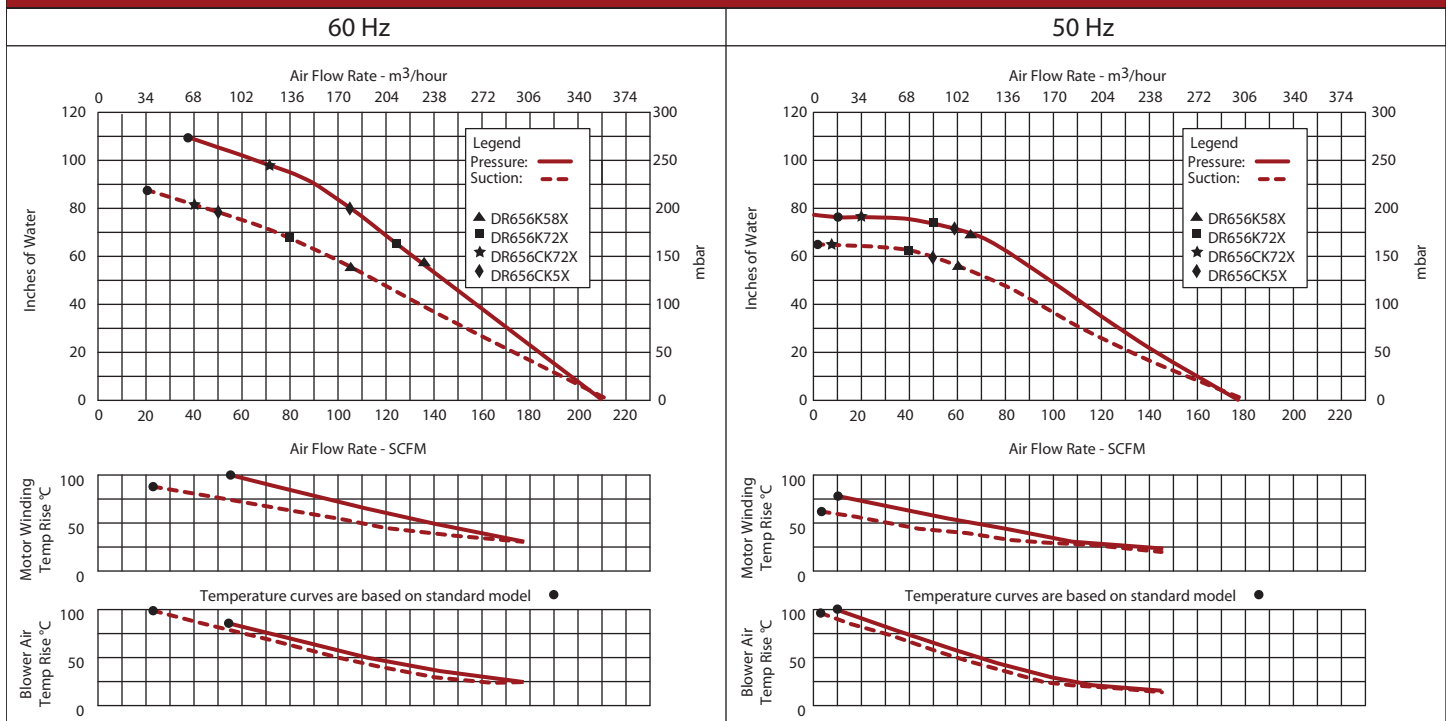

This document is for informational purposes only and should not be considered as a binding description of the products or their performance in all applications. The performance data on this page depicts typical performance under controlled laboratory conditions. AMETEK is not responsible for blowers driven beyond factory specified speed, temperature, pressure, flow or without proper alignment. Actual performance will vary depending on the operating environment and application. AMETEK products are not designed for and should not be used in medical life support applications. AMETEK reserves the right to revise its products without notification. The above characteristics represent standard products. For product designed to meet specific applications, contact AMETEK Technical & Industrial Products Sales department.