



Enviro-Equipment Inc.
10120 Industrial Drive
Pineville NC 28134

Stock #1521

Dimensions: Air Stripper – See Cut Sheet
Blower Skid: 48" x 40" x 73", 618 lb

Description: Shallow Tray 2631 Stainless Steel Air Stripper, 3 Trays, 115 GPM, 600 SCFM
7.5HP 3ph 3500RPM Aeration Blower on Stand with Inlet Screen and Discharge Butterfly Valve





Enviro-Equipment Inc.
10120 Industrial Drive
Pineville NC 28134



FRONT

RIGHT SIDE

MINIMUM CLEARANCE

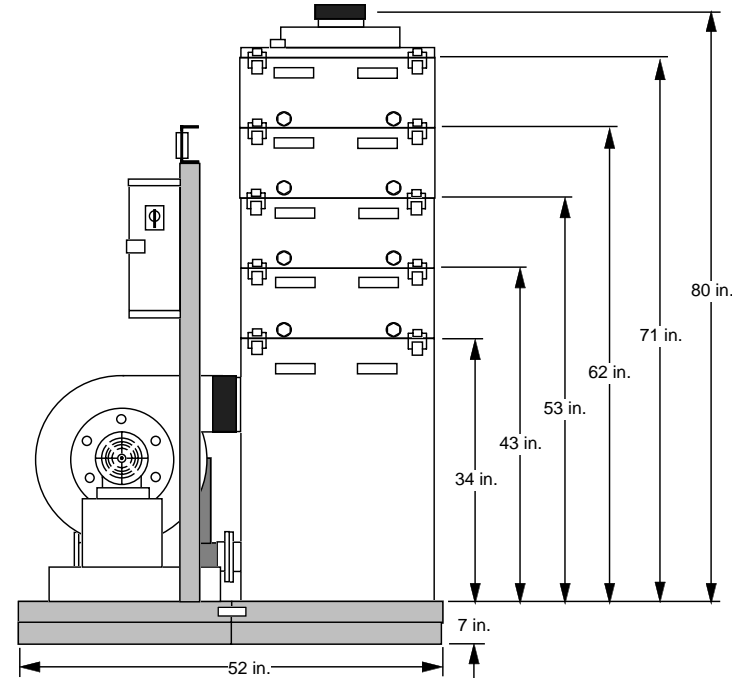
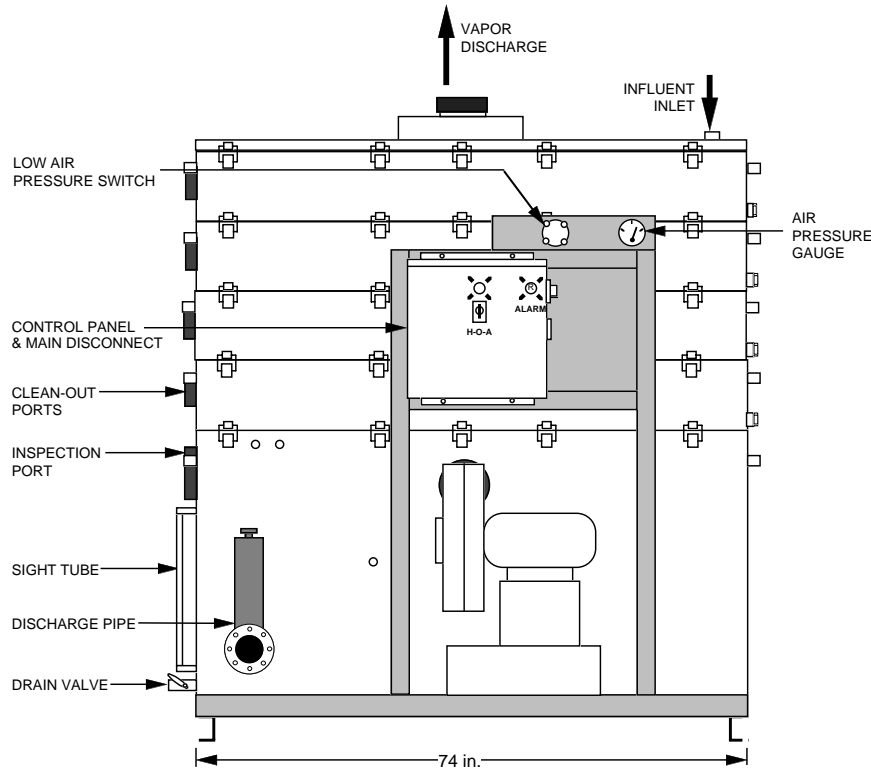

FRONT	1.5 ft.
TOP	15 in.
REAR	N/A
LEFT	6.5 ft.
RIGHT	1 ft.

BASIC SYSTEM

- ✓ SUMP TANK
- ✓ STRIPPER TRAYS
- ✓ BLOWER
- ✓ MIST ELIMINATOR
- ✓ PIPING
- ✓ SPRAY NOZZLE
- ✓ WATER LEVEL SIGHT TUBE
- ✓ GASKETS
- ✓ LATCHES

OPTIONAL ITEMS

- ✓ SKID & STANCHION
- ✓ GRAVITY DISCHARGE PIPING
- DISCHARGE PUMP
- FEED PUMP
- ADDITIONAL BLOWER
- EXPLOSION-PROOF MOTOR(S)
- LOCAL DISCONNECT NEMA 7
- ✓ CONTROL PANEL
- ✓ MAIN DISCONNECT SWITCH
- I.S. COMPONENTS/REMOTE MOUNT
- ✓ INTERMITTENT OPERATION
- STROBE LIGHT
- ALARM HORN
- POWER LAPSE INDICATOR
- ✓ LOW AIR PRESSURE ALARM SWITCH(ES)
- ✓ HIGH WATER LEVEL ALARM SWITCH
- DISCHARGE PUMP LEVEL SWITCH
- WATER PRESSURE GAUGE(S)
- DIGITAL WATER FLOW INDICATOR
- ✓ AIR PRESSURE GAUGE
- AIR FLOW METER
- TEMPERATURE GAUGE(S)
- LINE SAMPLING PORT(S)
- AIR BLOWER SILENCER
- ✓ WASHER WAND
- AUTO DIALER

NOTE: THIS DRAWING IS REPRESENTATIVE OF A STANDARD SHALLOWTRAY CONFIGURATION, AND IS NOT INTENDED FOR ENGINEERING DESIGN OR LAYOUT. ACTUAL ARRANGEMENT AND DIMENSIONS MAY VARY DEPENDING ON BLOWER SELECTION OR OTHER ACCESSORIES. PLEASE CONTACT NEEP FOR DETAILED DESIGN INFORMATION.

POWER: 3Ø, 460 Volt, 3 WIRE + GROUND 60 Hz
CONSULT N.E.E.P. FOR OTHER CAPACITIES AND VOLTAGE OPTIONS

CONNECTION INFORMATION

ITEM	SIZE
GRAVITY DISCHARGE	4"Ø FLANGE, PVC80
DISCHARGE PUMP	2"Ø FNPT
WATER INLET	2"Ø FNPT
AIR EXHAUST NOZZLE	8"Ø STUB w/8" CPLG

STRIPPER CONSTRUCTION:
304L STAINLESS STEEL

	NORTH EAST ENVIRONMENTAL PRODUCTS, INC. 7 COMMERCE AVENUE WEST LEBANON, NEW HAMPSHIRE 03784 PHONE: 603-298-7061 FAX: 603-298-7063 www.neepsystems.com		
	TOLERANCES UNLESS OTHERWISE SPECIFIED: ± 1 INCH $\delta_{x,y,z}$		
DRAWING NAME:		© 2002 NEEP	
DRAWING #:		ShallowTray® Model 2641	
DRAWN: DCS		CUSTOMER: NEEPSYSTEMS.com	
DATE: 10/08/02	SCALE: NTS	SHEET: 1 OF 1	



NEEP ShallowTray[®] Low Profile Air Strippers

- Discreet size designed for smaller spaces, indoors or outdoors
- Removes a wide variety of volatile organic contaminants
- Wide variety of sizes and number of trays used
- Cleaning ports allow easy in-place maintenance, using washing wand and pressure washer
- No removable trays, avoiding air leaks and decreases maintenance time, handling and consumable parts
- Guaranteed performance under specified conditions
- Over 10,000 analytical tests have been performed to confirm favorable results



The NEEP ShallowTray, invented in 1988, was the first low profile air stripper on the market. Since then, over 4,000 units have been installed worldwide. The ShallowTray modeler software program accurately sizes the unit for your application. With this program, equipment performance is guaranteed under specified conditions.

INLET CHAMBER

Influent wastewater enters into the unit through the inlet or optional spray nozzle. The wastewater will then flow over the weir and enter into the aeration trays.

INLET CONNECTIONS

All connections 3" and smaller are FNPT couplings. All connections 4" and larger are flanges

with ANSI 150 pound standard bolt circle. Flanged piping connections conform to ANSI B16.5.

AERATION TRAYS

Units are constructed out of polyethylene or stainless steel.

Once the wastewater starts to flow over the trays, clean air is blown up through 3/16" orific-

es that are strategically spaced in the tray. This injection of clean air will create a froth of bubbles, which generates a large mass transfer surface area. This surface area will volatilize the specified contaminants in the water.

More trays and larger sized units are used to strip the contaminants that require more

residence time to reach optimal volatilization.

The water will flow through a series of aeration tray channels and then flow down through the downcomer to the next tray or water holding sump tank.

OUTLET

Clean water exits the water holding sump tank through the outlet, either by pumped flow or gravity flow discharge.

FEATURES

All units include the following:

- Sump tank
- Cover
- Trays
- Air blower sized to number of trays
- Blower inlet screen and damper
- Mist eliminator
- Water inlet or optional spray nozzle
- Water level sight tube

- Gaskets
- Latches
- Internal piping
- Schedule 80 PVC
- Tray cleanout ports (for stainless steel models only)

For a full list of options, such as gauges, control panels, and alarm switches, see: hydroquipinc.com/air-strippers

NEEP SHALLOWTRAY® CYLINDRICAL (POLYETHYLENE) UNIT

SPECIFICATIONS

* Dimensions are approximate and do not include Skid. Actual dimensions will vary depending on options or blower selection.

** Induced draft configuration

Model	No. of Trays	Flow Rate (GPM)	Dimensions*		Sump Pump Range (GAL)	Sump Cap. (GAL)	Flood Vol. (GAL)	Airflow SCFM (MIN/MAX)	Delta P (IN-H ₂ O)	Air Duct Dia.		Liquid Connection		
			Ht.	Dia.						Sump Inlet	Outlet Cplg.	Inlet	Outlet Pumped	Outlet Gravity
1300-P SERIES														
NS-1311-P	1	0.5-15	3'11"	28"	15	28	49	150/195	6	8"	8" x 6"	1" FNPT	2" FNPT	2" FNPT
NS-1321-P	2	0.5-15	4'8"	28"	15	28	49	150/195	10	8"	8" x 6"	1" FNPT	2" FNPT	2" FNPT
NS-1331-P	3	0.5-15	5'9"	28"	15	28	49	150/195	14	8"	8" x 6"	1" FNPT	2" FNPT	2" FNPT
NS-1341-P	4	0.5-15	6'10"	28"	15	28	49	150/195	18	8"	8" x 6"	1" FNPT	2" FNPT	2" FNPT
2300-P SERIES														
NS-2311-P	1	1-50	4'6"	44"	34	65	114	300/390	6-10	8"	8" x 6"	1.25" FNPT	3" FNPT	3" FNPT
NS-2321-P	2	1-50	5'3"	44"	34	65	114	300/390	10-14	8"	8" x 6"	1.25" FNPT	3" FNPT	3" FNPT
NS-2331-P	3	1-50	6'0"	44"	34	65	114	300/390	14-18	8"	8" x 6"	1.25" FNPT	3" FNPT	3" FNPT
NS-2341-P	4	1-50	6'9"	44"	34	65	114	300/390	18-22	8"	8" x 6"	1.25" FNPT	3" FNPT	3" FNPT
NS-2351-P**	5	1-50	7'6"	44"	34	65	114	300/390	22-26	8"	8" x 6"	1.25" FNPT	3" FNPT	3" FNPT

NEEP SHALLOWTRAY® RECTANGULAR UNIT

SPECIFICATIONS

* Dimensions are approximate and do not include Skid. Actual dimensions will vary depending on options or blower selection.

** Induced draft configuration

Model	No. of Trays	Flow Rate (GPM)	Dimensions*			Sump Pump Range (GAL)	Sump Cap. (GAL)	Flood Vol. (GAL)	Airflow SCFM (MIN/MAX)	Delta P (IN-H ₂ O)	Air Duct Dia.		Liquid Connection	
			H	L	W						Sump Inlet	Outlet Cplg.	Inlet	Outlet Pumped

1300 SERIES

NS-1311	1	0.5-22.5	4'6"	3'0"	1'0"	10	20	42	150/195	6-10	8"	6"	1.25" FNPT	2" FNPT	2" FNPT
NS-1321	2	0.5-22.5	5'3"	3'0"	1'0"	10	20	42	150/195	10-14	8"	6"	1.25" FNPT	2" FNPT	2" FNPT
NS-1331	3	0.5-22.5	6'0"	3'0"	1'0"	10	20	42	150/195	14-18	8"	6"	1.25" FNPT	2" FNPT	2" FNPT
NS-1341	4	0.5-22.5	6'9"	3'0"	1'0"	10	20	42	150/195	18-22	8"	6"	1.25" FNPT	2" FNPT	2" FNPT
NS-1351	5	0.5-22.5	7'6"	3'0"	1'0"	10	20	42	150/195	22-26	8"	6"	1.25" FNPT	2" FNPT	2" FNPT
NS-1361**	6	0.5-22.5	8'3"	3'0"	1'0"	10	20	42	150/195	26-30	8"	6"	1.25" FNPT	2" FNPT	2" FNPT

2300 SERIES

NS-2311	1	1-45	4'6"	3'0"	2'0"	21	40	85	300/390	6-10	8"	6"	2" FNPT	3" FNPT	3" FNPT
NS-2321	2	1-45	5'3"	3'0"	2'0"	21	40	85	300/390	10-14	8"	6"	2" FNPT	3" FNPT	3" FNPT
NS-2331	3	1-45	6'0"	3'0"	2'0"	21	40	85	300/390	14-18	8"	6"	2" FNPT	3" FNPT	3" FNPT
NS-2341	4	1-45	6'9"	3'0"	2'0"	21	40	85	300/390	18-22	8"	6"	2" FNPT	3" FNPT	3" FNPT
NS-2351	5	1-45	7'6"	3'0"	2'0"	21	40	85	300/390	22-26	8"	6"	2" FNPT	3" FNPT	3" FNPT
NS-2361**	6	1-45	8'3"	3'0"	2'0"	21	40	85	300/390	26-30	8"	6"	2" FNPT	3" FNPT	3" FNPT

* Dimensions are approximate and do not include Skid. Actual dimensions will vary depending on options or blower selection.
 ** Induced draft configuration

Model	No. of Trays	Flow Rate (GPM)	Dimensions*			Sump Pump Range (GAL)	Sump Cap. (GAL)	Flood Vol. (GAL)	Airflow SCFM (MIN/MAX)	Delta P (IN-H ₂ O)	Air Duct Dia.		Liquid Connection	
			H	L	W						Sump Inlet	Outlet Cplg.	Inlet	Outlet Pumped

2600 SERIES

NS-2611	1	2-115	4'6"	6'0"	2'0"	42	80	170	600/780	6-10	8"	2" FNPT	4" FNPT	4" FLG
NS-2621	2	2-115	5'3"	6'0"	2'0"	42	80	170	600/780	10-14	8"	2" FNPT	4" FNPT	4" FLG
NS-2631	3	2-115	6'0"	6'0"	2'0"	42	80	170	600/780	14-18	8"	2" FNPT	4" FNPT	4" FLG
NS-2641	4	2-115	6'9"	6'0"	2'0"	42	80	170	600/780	18-22	8"	2" FNPT	4" FNPT	4" FLG
NS-2651	5	2-115	7'6"	6'0"	2'0"	42	80	170	600/780	22-26	8"	2" FNPT	4" FNPT	4" FLG
NS-2661**	6	2-115	8'3"	6'0"	2'0"	42	80	170	600/780	26-30	8"	2" FNPT	4" FNPT	4" FLG

3600 SERIES

NS-3611	1	3-160	4'6"	6'0"	3'0"	64	121	255	900/1170	6-10	8"	3" FNPT	4" FNPT	6" FLG
NS-3621	2	3-160	5'3"	6'0"	3'0"	64	121	255	900/1170	10-14	8"	3" FNPT	4" FNPT	6" FLG
NS-3631	3	3-160	6'0"	6'0"	3'0"	64	121	255	900/1170	14-18	8"	3" FNPT	4" FNPT	6" FLG
NS-3641	4	3-160	6'9"	6'0"	3'0"	64	121	255	900/1170	18-22	8"	3" FNPT	4" FNPT	6" FLG
NS-3651	5	3-160	7'6"	6'0"	3'0"	64	121	255	900/1170	22-26	8"	3" FNPT	4" FNPT	6" FLG
NS-3661**	6	3-160	8'3"	6'0"	3'0"	64	121	255	900/1170	26-30	8"	3" FNPT	4" FNPT	6" FLG

31200 SERIES

NS-31211	1	6-425	5'7"	11'8"	2'10"	116	301	587	1800/2340	6-10	10"	4" FLG	4" FNPT	8" FLG
NS-31221	2	6-425	6'7"	11'8"	2'10"	116	301	587	1800/2340	10-14	10"	4" FLG	4" FNPT	8" FLG
NS-31231	3	6-425	7'7"	11'8"	2'10"	116	301	587	1800/2340	14-18	10"	4" FLG	4" FNPT	8" FLG
NS-31241	4	6-425	8'7"	11'8"	2'10"	116	301	587	1800/2340	18-22	10"	4" FLG	4" FNPT	8" FLG
NS-31251	5	6-425	9'7"	11'8"	2'10"	116	301	587	1800/2340	22-26	10"	4" FLG	4" FNPT	8" FLG
NS-31261**	6	6-425	10'7"	11'8"	2'10"	116	301	587	1800/2340	26-30	10"	4" FLG	4" FNPT	8" FLG

* Dimensions are approximate and do not include Skid. Actual dimensions will vary depending on options or blower selection.

** Induced draft configuration

Model	No. of Trays	Flow Rate (GPM)	Dimensions*			Sump Pump Range (GAL)	Sump Cap. (GAL)	Flood Vol. (GAL)	Airflow SCFM (MIN/MAX)	Delta P (IN-H ₂ O)	Air Duct Dia.		Liquid Connection	
			H	L	W						Sump Inlet	Outlet Cplg.	Inlet	Outlet Pumped

41200 SERIES

NS-41211	1	8-550	5'7"	12'0"	4'0"	171	442	862	2400/3120	6-10	10"	18"	6" FLG	4" FNPT	10" FLG
NS-41221	2	8-550	6'7"	12'0"	4'0"	171	442	862	2400/3120	10-14	10"	18"	6" FLG	4" FNPT	10" FLG
NS-41231	3	8-550	7'7"	12'0"	4'0"	171	442	862	2400/3120	14-18	10"	18"	6" FLG	4" FNPT	10" FLG
NS-41241	4	8-550	8'7"	12'0"	4'0"	171	442	862	2400/3120	18-22	10"	18"	6" FLG	4" FNPT	10" FLG
NS-41251	5	8-550	9'7"	12'0"	4'0"	171	442	862	2400/3120	22-26	10"	18"	6" FLG	4" FNPT	10" FLG
NS-41261**	6	8-550	10'7"	12'0"	4'0"	171	442	862	2400/3120	26-30	10"	18"	6" FLG	4" FNPT	10" FLG

61200 SERIES

NS-61211	1	12-1000	5'7"	12'0"	6'0"	256	663	1293	3600/4680	6-10	12"	18"	8" FLG	4" FNPT	12" FLG
NS-61221	2	12-1000	6'7"	12'0"	6'0"	256	663	1293	3600/4680	10-14	12"	18"	8" FLG	4" FNPT	12" FLG
NS-61231	3	12-1000	7'7"	12'0"	6'0"	256	663	1293	3600/4680	14-18	12"	18"	8" FLG	4" FNPT	12" FLG
NS-61241	4	12-1000	8'7"	12'0"	6'0"	256	663	1293	3600/4680	18-22	12"	18"	8" FLG	4" FNPT	12" FLG
NS-61251	5	12-1000	9'7"	12'0"	6'0"	256	663	1293	3600/4680	22-26	12"	18"	8" FLG	4" FNPT	12" FLG
NS-61261**	6	12-1000	10'7"	12'0"	6'0"	256	663	1293	3600/4680	26-30	12"	18"	8" FLG	4" FNPT	12" FLG

81200 SERIES

NS-81211	1	16-1300	5'7"	12'0"	8'0"	342	884	1724	4800/6240	6-10	12"	18"	8" FLG	4" FNPT	12" FLG
NS-81221	2	16-1300	6'7"	12'0"	8'0"	342	884	1724	4800/6240	10-14	12"	18"	8" FLG	4" FNPT	12" FLG
NS-81231	3	16-1300	7'7"	12'0"	8'0"	342	884	1724	4800/6240	14-18	12"	18"	8" FLG	4" FNPT	12" FLG
NS-81241	4	16-1300	8'7"	12'0"	8'0"	342	884	1724	4800/6240	18-22	12"	18"	8" FLG	4" FNPT	12" FLG
NS-81251	5	16-1300	9'7"	12'0"	8'0"	342	884	1724	4800/6240	22-26	12"	18"	8" FLG	4" FNPT	12" FLG
NS-81261**	6	16-1300	10'7"	12'0"	8'0"	342	884	1724	4800/6240	26-30	12"	18"	8" FLG	4" FNPT	12" FLG

Cylindrical (Polyethylene) Unit

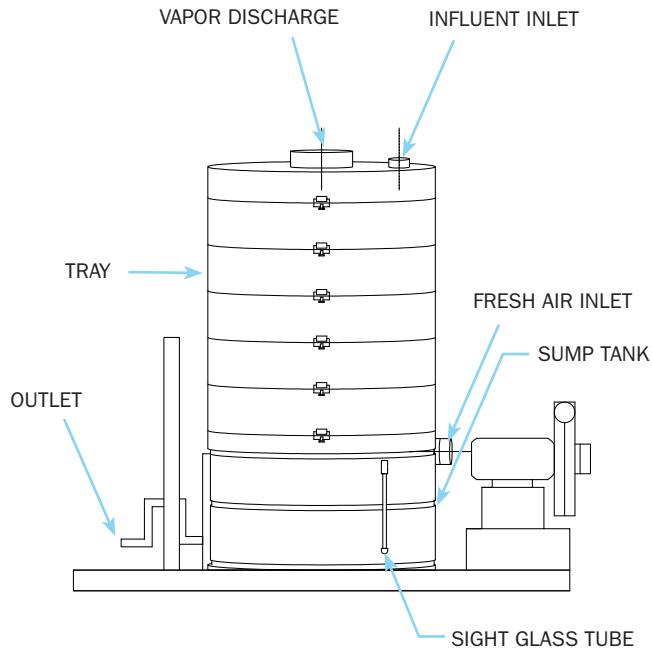

Rectangular Unit

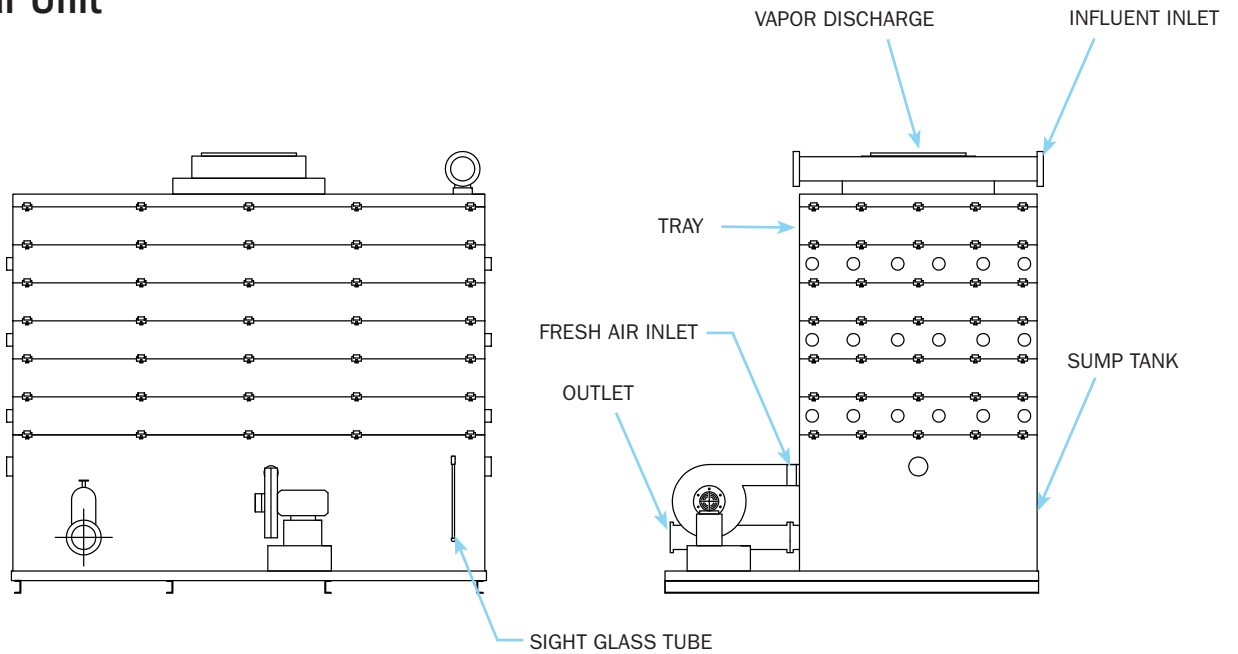

Whether an off-the-shelf unit or customized equipment, we'll help you determine the best solution for your application and site-specific needs.

TEL: 508-399-5771

FAX: 508-399-5352

108 Pond St, Seekonk, MA 02703

hqisales@hydroquipinc.com

www.hydroquipinc.com