



**Stock # 1500 Enclosed SVE System**

**Dimensions: 59" L x 48" W x 77" H    Weight: 1438 Pounds**

SVE System inside of Enclosure Including:

- Rotron EN6F5L 5HP 1PH 230V XP Blower – 225 CFM Max, 85" WC Max Vacuum
- 2" Solberg Inlet Vacuum Filter
- 2" Solberg Exhaust Silencer
- 2" Solberg Filter Silencer with 2" Brass Gate Valve (Dilution Valve)
- Vacuum Gauges
- Rotron MS200PS Moisture Separator with XP High Level Float and manual drain
- 4 Zone Inlet Manifold Each Leg Includes Ball Valve and 2" FNPT Connection
- Dwyer 1950 XP Low Vacuum Switch with adjustable 4-20" WC Range
- 4' W x 4' L x 6' H Enclosure Including
  - o XP Exhaust Fan with Thermostat
  - o XP Heater with Thermostat
  - o 1" Thick Sound Foam
  - o Interior Wired for Class 1 Div 2 Hazardous Location
- UL 508/698 Weatherproof Relay Logic Control Panel mounted on exterior. 230V 1PH 33 Full Load Amps.





**Enviro-Equipment, Inc.**  
**Remediation Division**







**Enviro-Equipment, Inc.**  
**Remediation Division**



# ROTRON® Regenerative Blowers

## EN 6 & CP 6 Sealed Regenerative Blower w/Explosion-Proof Motor

### FEATURES

- Manufactured in the USA – ISO 9001 compliant
- Maximum flow: 225 SCFM
- Maximum pressure: 104 IWG
- Maximum vacuum: 85 IWG
- Standard motor: 5.0 HP, explosion-proof
- Cast aluminum blower housing, cover, impeller & manifold; cast iron flanges (threaded); teflon lip seal
- UL & CSA approved motor with permanently sealed ball bearings for explosive gas atmospheres Class I Group D minimum
- Sealed blower assembly
- Quiet operation within OSHA standards

### MOTOR OPTIONS

- International voltage & frequency (Hz)
- Chemical duty, high efficiency, inverter duty or industry-specific designs
- Various horsepower for application-specific needs

### BLOWER OPTIONS

- Corrosion resistant surface treatments & sealing options
- Remote drive (motorless) models
- Slip-on or face flanges for application-specific needs

### ACCESSORIES (See Catalog Accessory Section)

- Flowmeters reading in SCFM
- Filters & moisture separators
- Pressure gauges, vacuum gauges & relief valves
- Switches – air flow, pressure, vacuum or temperature
- External mufflers for additional silencing
- Air knives (used on blow-off applications)
- Variable frequency drive package

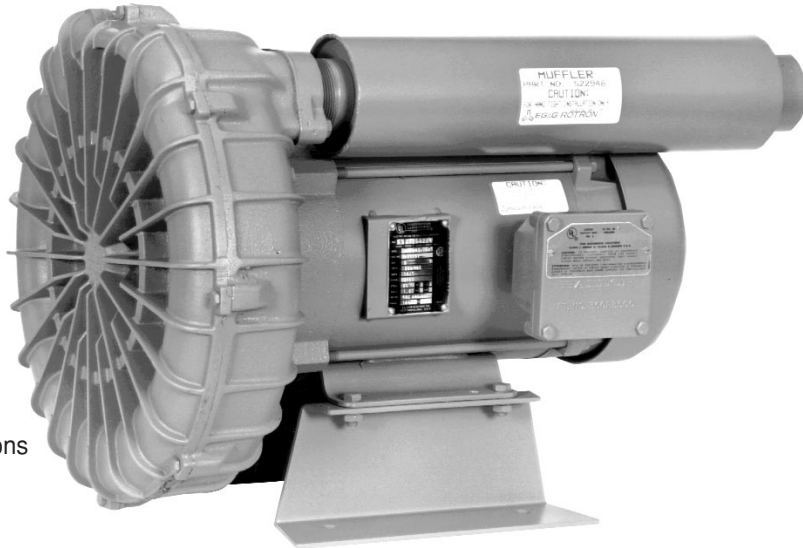

### BLOWER PERFORMANCE AT STANDARD CONDITIONS

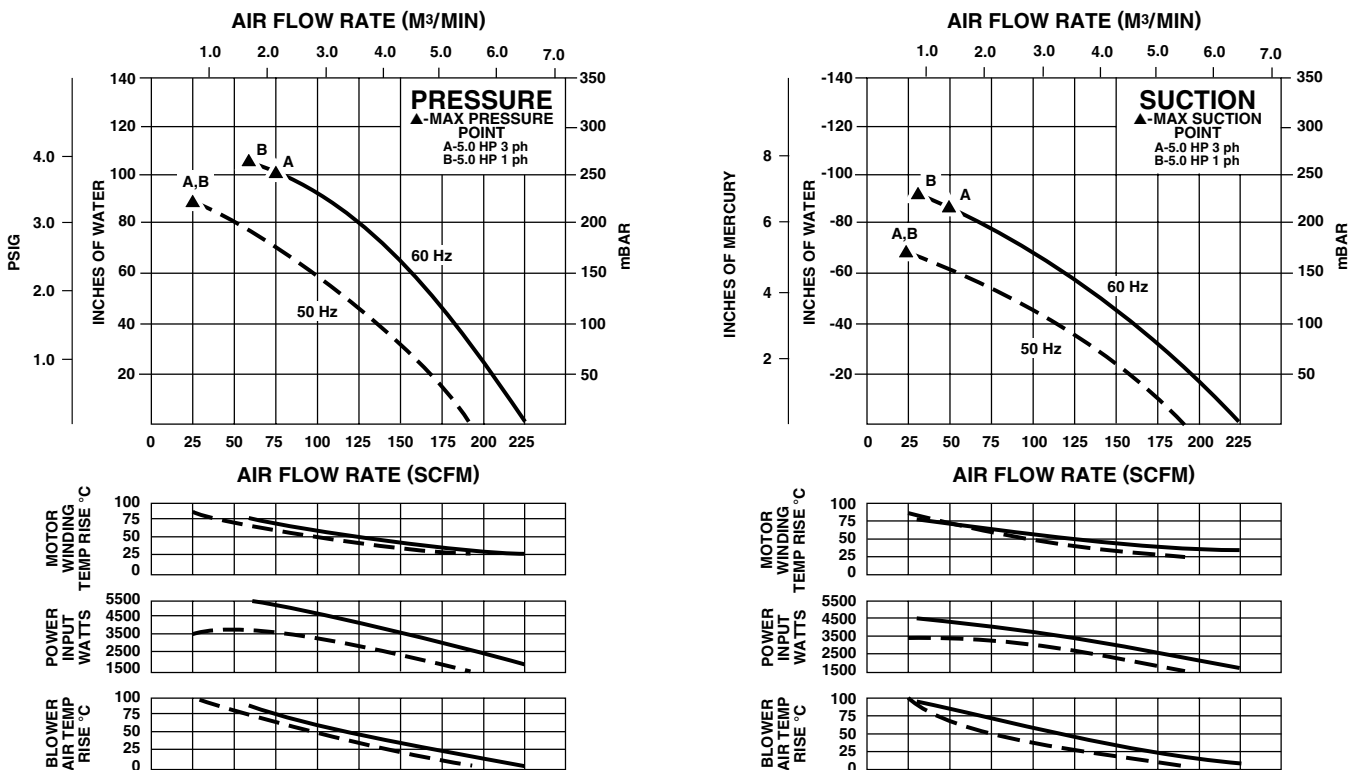

Rev. 2/04

# ROTRON® Regenerative Blowers

## EN 6 & CP 6 Sealed Regenerative Blower w/Explosion-Proof Motor

Scale CAD drawing available upon request.

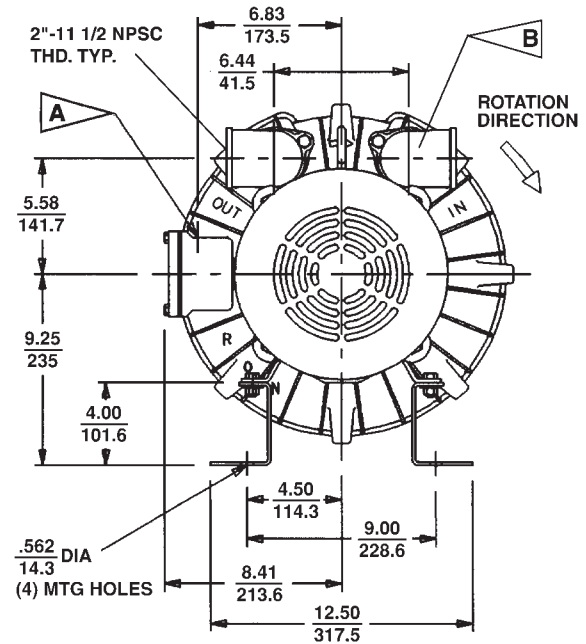
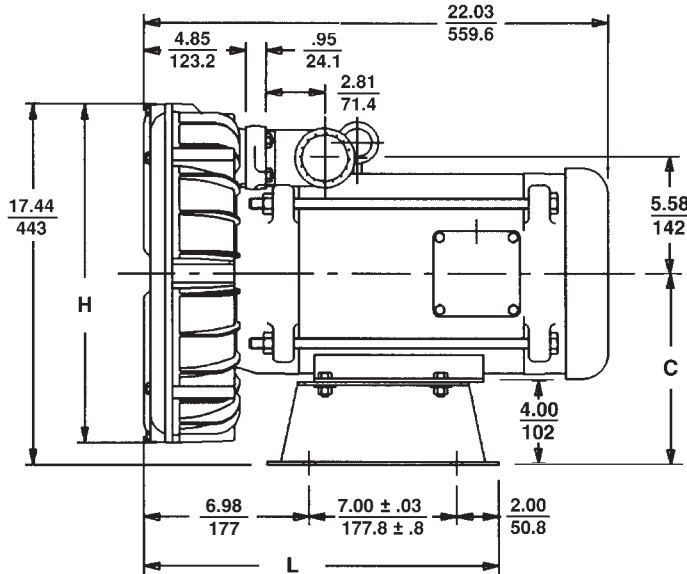

DIMENSIONS:  $\frac{\text{IN}}{\text{MM}}$   
TOLERANCES:  $.XX \pm \frac{.12}{3}$   
(UNLESS OTHERWISE NOTED)

MODEL	L (IN/MM)	C (IN/MM)	H (IN/MM)
EN/CP6F72L	20.37/517	8.5/216	16.7/424
EN/CP6F5L	22.0/560	10.21/259	17.5/443

**A** 0.75" NPT CONDUIT CONNECTION AT 12 O'CLOCK POSITION

**B** 90° ELBOW SUPPLIED ON 1 PHASE MODEL ONLY

### SPECIFICATIONS

ALL PRODUCTS LISTED INCLUDE MUFFLER PN 522948

MODEL	EN6F5L	EN6F72L	EN6F86L	CP6FW5LR	CP6FW72LR
Part No.	038361	038180	038438	-	038978
Motor Enclosure – Shaft Material	Explosion-proof – CS	Explosion-proof – CS	Explosion-proof – CS	Chem XP – SS	Chem XP – SS
Horsepower	5.0	5.0	5.0	Same as EN6F5L – 038361 except add Chemical Processing (CP) features from catalog inside front cover	Same as EN6F72L – 038180 except add Chemical Processing (CP) features from catalog inside front cover
Phase – Frequency <sup>1</sup>	Single - 60 Hz	Three - 60 Hz	Three - 60 Hz		
Voltage <sup>1</sup>	230	230   460	575		
Motor Nameplate Amps	19.5	14   7	5.7		
Max. Blower Amps <sup>3</sup>	23	15.8   7.9	6.3		
Inrush Amps	175	152   76	38		
Starter Size	2	1   0	0		
Service Factor	1.0	1.0	1.0		
Thermal Protection <sup>2</sup>	Class B - Pilot Duty	Class B - Pilot Duty	Class B - Pilot Duty		
XP Motor Class – Group	I-D, II-F&G	I-D, II-F&G	I-D, II-F&G		
Shipping Weight	232 lb (105 kg)	160 lb (73 kg)	160 lb (73 kg)		

<sup>1</sup> Rotron motors are designed to handle a broad range of world voltages and power supply variations. Our dual voltage 3 phase motors are factory tested and certified to operate on both: **208-230/415-460 VAC-3 ph-60 Hz** and **190-208/380-415 VAC-3 ph-50 Hz**. Our dual voltage 1 phase motors are factory tested and certified to operate on both: **104-115/208-230 VAC-1 ph-60 Hz** and **100-110/200-220 VAC-1 ph-50 Hz**. All voltages above can handle a ±10% voltage fluctuation. Special wound motors can be ordered for voltages outside our certified range.

<sup>2</sup> Maximum operating temperature: Motor winding temperature (winding rise plus ambient) should not exceed 140°C for Class F rated motors or 120°C for Class B rated motors. Blower outlet air temperature should not exceed 140°C (air temperature rise plus inlet temperature). Performance curve maximum pressure and suction points are based on a 40°C inlet and ambient temperature. Consult factory for inlet or ambient temperatures above 40°C.

<sup>3</sup> Maximum blower amps corresponds to the performance point at which the motor or blower temperature rise with a 40°C inlet and/or ambient temperature reaches the maximum operating temperature.

Specifications subject to change without notice. Please consult your Local Field Sales Engineer for specification updates.

Rev. 2/04

AMETEK Technical and Industrial Products, Kent, OH 44240 • e mail: rotronindustrial@ametek.com • internet: www.ametekmd.com

C-16