



ENVIRO-EQUIPMENT

REMEDIAION DIVISION

STOCK# 1368

REFURBISHED EQUIPMENT

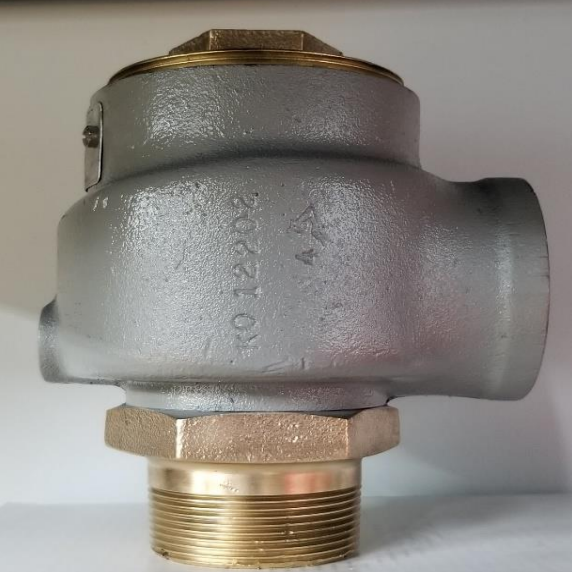
ITEM: KUNKLE 215V VACUUM RELEIF VALVE	SPECIFICATION
	<p>MANUFACTURER: EMERSON MODEL: 215V - HO1 VACUUM RANGE: Set at 5" HG (67.98" of H2O) MAX. FLOW (SCFM): 331 CONNECTIONS: 2" THREADED NPT TEMP. RANGE: -20^F to 406^F SERIAL NO:N/A EEI SN 190611-01</p>
	<p style="text-align: center;">FEATURES</p> <ul style="list-style-type: none"> * Large nozzle design provides high capacity flow. * Flat bronze valve seats ar lapped for optimum performance. * Warn ring offers easy adjustability for percise opening with minimum pre-open or simmer. * Pivot between disc and spring corects misalignment and and compensates for spring side thrust * Has seal cap for vacuum service.

GENERAL APPLICATION

EMERSON Kunkle Model 215V Vacuum Relief Valve is suitable for the protection of high volume vacuum pumps, conveying systems, and light gauge tanks.

PARTS AND MATERIALS

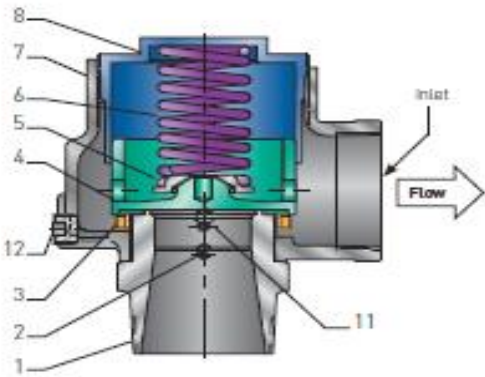

MODEL 215V

Part No.	Part Name	
1	Nozzel	Bronze, SB62 or Brass B283-C48500
2	Set Screw	Steel A108-1018 Brass Plated
3	Regulator Ring	Bronze BS584 alloy 84400
4	Disc	Bronze BS584 alloy 84401
5	Spring Step	Steel A109 Coated
6	Spring	SS, A313 TY 302 or 17-7
7	Body	Cast Iron A-126, CL A or B
8	Compression Screw	Bronze BS584 alloy 84400
11	Reg. Ring Set Screw	N/A
12	NPT Drain Plug	Steel A108-1018

SPECIFICATIONS

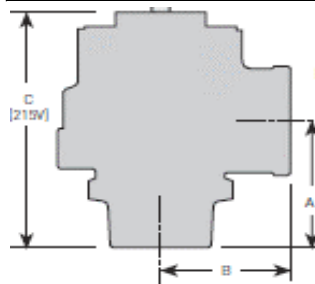

A	3 1/4"
B	3"
C	6 1/2"
Weight (lb)	8-Lb