

Protege User Guide



*PROTEGE PORTABLE GAS
MONITOR*

087-0038

Rev L





Protege User Guide

PROTEGE PORTABLE GAS MONITOR

087-0038

Rev L

© 2011 Scott Safety. SCOTT, the SCOTT SAFETY Logo, Scott Safety Health and Safety, Protege, Proton, Scout, Freedom, Masterdock are registered and/or unregistered marks of Scott Technologies, Inc. or its affiliates.

All rights reserved. No part of this documentation may be reproduced in any form or by any means or used to make any derivative work (such as translation, transformation, or adaptation) without written permission from Scott Safety.

Scott Safety reserves the right to revise this documentation and to make changes in content from time to time without obligation on the part of Scott Safety to provide notification of such revision or change.

Scott Safety provides this documentation without warranty, term, or condition of any kind, either implied or expressed, including, but not limited to, the implied warranties, terms or conditions of merchantability, satisfactory quality, and fitness for a particular purpose. Scott Safety may make improvements or changes in the product(s) described in this documentation at any time.

While every effort has been made to ensure accuracy in this guide, no responsibility can be accepted for errors or omissions. This publication is not intended to form the basis of a contract, and the company reserves the right to amend the design, content, and specifications of the detector without notice.

Scott Safety, 4320 Goldmine Road, Monroe, NC 28110, Telephone 800-247-7257, FAX 704-291-8330, E-mail techsupport.scottths.us@tycoint.com, Web www.scottsafety.com

Microsoft, Windows, Windows 2000, Windows Me, Windows XP, Windows NT, Windows Vista, Windows 7, Internet Explorer and MS-DOS are either trademarks or registered trademarks of Microsoft Corporation in the United States and other countries. Solaris and JAVA are either trademarks or registered trademarks of Sun Microsystems, Inc. All other products or service names are the property of their respective owners.

The international transport of this device is regulated under United States export regulations and may be regulated by the import regulations of other countries.

SCOTT CONTENTS

About This Guide

Guide Overview	xi
Using Scott Safety Electronic Documents	xii
Guide Conventions	xiii
Related Product Documentation	xiv
Revision History	xv
Certifications and Approvals	xvi
General Safety Information	xix
Warnings and Cautions – Device Use and Care	xx
Warnings and Cautions – Sensor Use and Care	xxii
Warnings and Cautions – Battery Use and Care	xxiii
Acronyms	xxiv

CHAPTER 1

Introduction

Chapter Overview	1
Device Overview	2

CHAPTER 2

Installation

Chapter Overview	5
Planning for Installation	6
Verifying Items Shipped	6
Downloading Software	6
Charging the Battery	6
Charging the Battery with the Multi-Charger (Optional)	8
Installation Checklist	11
Installing the SGM software	11
Installing the JAVA Runtime Environment (JRE) Software	15
Installing the Optional Pump	17
Installing - Device Powered Down	18
Installing - Device Powered Up	19
Disconnecting the Optional Pump	19

CHAPTER 3

Configuration and Setup

Chapter Overview	21
Configuration and Setup Checklist	22
Connecting the Device to a PC	22
Configuring the Scott Gas Monitor Software	23
SGM Defaults	27

CHAPTER 4	Operation	
	Chapter Overview	29
	Operating the Device	30
	LCD Alerts and Displays	31
	Powering Up	33
	Powering Down	35
CHAPTER 5	Maintenance	
	Chapter Overview	37
	Calibrating the Device	38
	Zero Calibration	39
	Span Calibration	40
	Bump Testing	43
	Maintaining the Device	44
	Replacing the Sensor	44
	Cleaning the Pump	46
	Troubleshooting the Device	51
APPENDIX A	Specifications	
	Appendix Overview	53
	Specifications	54
APPENDIX B	Quick Reference	
	Appendix Overview	57
	Quick Setup	58
	Alerts & Messages	58
	Powering the Device	59
	Daily Bump Test	60
	Daily Zero Calibration	60
	Span Gas Calibration	60
	Optional Pump	61
APPENDIX C	Sensor Information	
	Appendix Overview	63
	Sensor K-Factors	64
	Gas Interferences	65
APPENDIX D	Support	
	Appendix Overview	67
	Assistance	68
	Parts List	69
	Warranty Statement	73
	Product Information	74
	Index	75

LIST OF FIGURES

1	Major Parts	3
2	Charging the Battery	7
3	Multi-Charger Mounting	8
4	Multi-Charger Use	9
5	Multi-Charger Cleaning	10
6	Windows Vista OS Only	12
7	Scott Gas Monitor Software Installation (1 of 5)	13
8	Scott Gas Monitor Software Installation (2 of 5)	13
9	Scott Gas Monitor Software Installation (3 of 5)	14
10	Scott Gas Monitor Software Installation (4 of 5)	14
11	Scott Gas Monitor Software Installation (5 of 5)	15
12	JAVA JRE Software Installation (1 of 3)	16
13	JAVA JRE Software Installation (2 of 3)	16
14	JAVA JRE Software Installation (3 of 3)	17
15	Pump Installation.	18
16	Pump Displays - Start Up	19
17	Device Icon	22
18	Connecting the Device to a PC	23
19	Scott Gas Monitor (SGM) Software Home Screen	24
20	Scott Gas Monitor (SGM) Software Settings Screen	24
21	Scott Gas Monitor (SGM) Software Set Clock Screen	25
22	Scott Gas Monitor (SGM) Software View Log Screen.	26
23	LCD Indicators	30
24	Power Up Buttons	33
25	Zero Calibration Display - In Progress	39
26	Zero Calibration Display - Passed.	40
27	Zero Calibration Display - Failed.	40
28	Span Calibration - Calibration Adapter Attached.	42
29	Span Calibration - LCD Display Sequence	42
30	Bump Test - Calibration Adapter Attached	43
31	Removing Device Cover	45
32	Removing Sensor	45
33	Sensor Pin Alignment	46
34	Removing Pump Screws	47
35	Disassembly of Pump	47
36	Pump Ports and Hoses	48
37	Setup Syringe	48
38	Routing the Pump Wires	49
39	Pump Reassembly	50
40	Connecting the Device to a PC	58

VIII LIST OF FIGURES

41	Left and Right Operation Buttons	59
42	Span Calibration - Calibration Adapter Attached	60
43	Pump Installation	61

SCOTT LIST OF TABLES

1	Navigating Within a PDF Document	xii
2	Scott Safety Documentation Set	xiv
3	Protege User Guide Revision History	xv
4	Certifications and Approvals	xvi
5	Acronyms	xxiv
6	Major Parts	4
7	Installation Checklist	11
8	Configuration and Setup Checklist	22
9	SGM Defaults	27
10	LCD Items and Descriptions	31
11	Recommended Calibration and Test Matrix	39
12	Recommended Maintenance Matrix	44
13	Troubleshooting Matrix	51
14	Device Specifications	54
15	Hydrogen Sulfide Sensor Specifications	54
16	Carbon Monoxide Sensor Specifications	55
17	Oxygen Sensor Specifications	55
18	Combustible Sensor Specifications	55
19	Combustible Sensor K-Factors	64
20	Gas Interferences	65
21	Applicable Parts List	69

Guide Overview

This guide describes the steps required to use the Protege. This document is for gas detection personnel to manage their gas monitoring device. This document contains information on installation, configuration, operation, maintenance and troubleshooting.

This user guide assumes a basic knowledge of gas detection procedures.

The user guide is divided into the following topics:

- [Introduction](#)
- [Installation](#)
- [Configuration and Setup](#)
- [Operation](#)
- [Maintenance](#)
- [Quick Reference](#)
- [Specifications](#)
- [Sensor Information](#)
- [Support](#)



Warning: *Read, understand and follow the entire content of this guide prior to use. Failure to do so may result in serious injury or death.*

Using Scott Safety Electronic Documents

Scott Safety electronic documents are provided as PDF files. Open and view them using the Adobe® Acrobat® Reader application, version 3.0 or later. If necessary, download the Acrobat Reader from the Adobe Systems, Inc. web site:

<http://www.adobe.com/prodindex/acrobat/readstep.html>

Each provided PDF file offers several ways for moving among the document’s pages, as follows:

To move quickly from section to section within the document, use the *Acrobat bookmarks* that appear on the left side of the Acrobat Reader window. The bookmarks provide an expandable outline view of the document’s contents. To display the document’s Acrobat bookmarks, press the “Display both bookmarks and page” button on the Acrobat Reader tool bar.

To move to the referenced page of an entry in the document’s Contents or Index, click on the entry itself, each of which is hyperlinked.

To follow a [cross-reference](#) to a heading, figure, or table, click the blue text.

To move to the beginning or end of the document, to move page by page within the document, or to navigate among the pages you displayed by clicking on hyperlinks, use the Acrobat Reader navigation buttons shown in this figure:

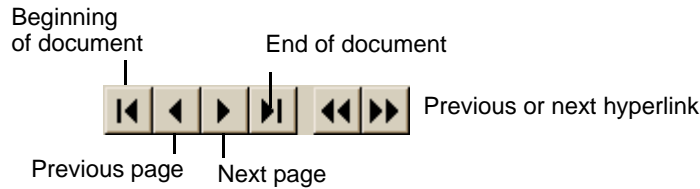

[Table 1](#) summarizes how to navigate within a Scott Safety electronic document.

Table 1 Navigating Within a PDF Document

TO NAVIGATE THIS WAY	CLICK THIS
Move from section to section within the document.	A bookmark on the left side of the Acrobat Reader window
Move to an entry in the Table of Contents.	The entry itself
Move to an entry in the Index.	The page number
Move to an entry in the List of Figures or List of Tables.	The Figure or Table number
Follow a cross-reference (highlighted in blue text).	The cross-reference text
Move page by page.	The appropriate Acrobat Reader navigation buttons
Move to the beginning or end of the document.	The appropriate Acrobat Reader navigation buttons
Move backward or forward among a series of hyperlinks you have selected.	The appropriate Acrobat Reader navigation buttons

Guide Conventions

The following visual elements are used throughout this guide, where applicable:



Warning: *This icon and text indicate a potentially hazardous situation, which, if not avoided, could result in death or injury.*



Caution: *This icon and text indicates a potentially dangerous procedure. Instructions contained in the warning must be followed. Failure to do so may result in damage to the device.*



This icon and text indicate the possibility of electrostatic discharge (ESD) in a procedure that requires the reader to take the proper ESD precautions.



This icon and text designates information of special note.

Related Product Documentation

[Table 2](#) lists the Scott Safety Family documentation set.

Table 2 Scott Safety Documentation Set

DOCUMENT NAME	PURPOSE	DOCUMENT ID
<i>Protege Masterdock Docking Station Manual</i>	Covers use, operation and maintenance.	087-0045

Revision History

Table 3 shows the revision history for this guide, providing a description of the changes.

Table 3 Protege User Guide Revision History

REVISION	CHANGE
K	Added record of revisions, updated parts list, updated toxic gas interference table, added Microsoft Windows® 7 as new OS for the SGM software, added a Note about powering down the device prior to new calibration values being saved, updated company name, copyright and contact information, updated content for ease of use and made various corrections throughout. Updated certifications and approvals section. Updated part numbers. Updated cross references, tables, figures and headings. As well as, other related maintenance items.
L	<ul style="list-style-type: none"> • Re-structured entire manual. • About This Guide chapter – Added IEC pending approval, Gost approval, Chinese approval, CSA approval and updated Inmetro approval. Added Protege Masterdock Docking Station Manual to related documents table. Added European disposal requirements. Added a caution not to operate device within 1 to 2’ of a high-powered portable radio. • Introduction chapter – Added content about Protege Masterdock Docking Station. Changed data log up to events from 4000 to 7000. Added 12 hours typical run time with pump. • Installation chapter – Added content about downloading Scott Gas Monitor (SGM) software from our Web site, un-installing lower version of SGM and added content about Multi-Charger. Added requirement for JRE 32-bit software. Added details for Windows 7 64-bit OS and for Windows Vista. Added details about administrator privileges. • Configuration and Setup chapter – Updated SGM Home Tab screen to include Portuguese button. • Maintenance chapter – Corrected location of Inlet and Outlet Ports in figure. Bump testing section, changed 10% to +/-20% regarding verification of readings. Added troubleshooting information related to exposure to high-powered portable radios. • Specifications appendix – Added Data Log Event value. Added Nominal Voltage value. Corrected CO Sensor range. • Quick Reference appendix – Added to manual. • Support appendix – Added more part numbers with photos to parts list. Added combustible sensor (CSA) part number. Added two new Calibration kits. • Added Scott Safety branding items and updated URL for SGM downloads. • Updated cross references, tables, figures and headings. As well as, other related maintenance items.

Certifications and Approvals

Table 4 shows the device has been tested and complies with the following directives, standards, or standardized documents.

Table 4 Certifications and Approvals



SYMBOL	SPECIFIC DIRECTIVES, STANDARDS	MONROE, US FACTORY	SKELMERSDALE, UK FACTORY	SHANGHAI, CHINA FACTORY
 CLASS I DIVISION 1 GROUPS A B C D Ambient temperature: -20°C to +50°C	UL913	Applicable	N/A	N/A
 CLASS I DIVISION 1 GROUPS A B C D T4 Ambient temperature: -20°C to +50°C Intrinsically Safe Sécurité Intrinsèque Maybe used with Pump P/N 096-3259	CSA C22.2 No. 152-M1984 CSA C22.2 No. 157-92 CSA C22.2 No. 0-M91	Applicable	N/A	N/A
 Ex d ia IIC T4 DEMKO 08 ATEX 0813482X Ambient temperature: -20°C to +50°C *See Special Conditions for Safe Use	EN 60079-0 EN 60079-1 EN 60079-11	Applicable	Applicable	N/A

Table 4 Certifications and Approvals (continued)





SYMBOL	SPECIFIC DIRECTIVES, STANDARDS	MONROE, US FACTORY	SKELMERSDALE, UK FACTORY	SHANGHAI, CHINA FACTORY
 <p>Ex d ia IIC T4 IECEx (Pending) Ambient temperature: -20°C to +50°C *See Special Conditions for Safe Use</p>	<p>IEC 60079-0 IEC 60079-1 IEC 60079-11</p>	<p>Applicable</p>	<p>Applicable</p>	<p>N/A</p>
<p>Segurança</p>  <p>BR-Ex d ia IIC T4 10/UL-BRCO-0009X 10/UL-BRCO-0010X Ambient temperature: -20°C to +50°C (Protege) 0°C to +45°C (Accessories) *See Special Conditions for Safe Use</p>	<p>INMETRO Portaria 83 IEC 60079-0 IEC 60079-1 IEC 60079-11</p>	<p>Applicable</p>	<p>N/A</p>	<p>N/A</p>
 <p>Ex d ia IIC T4 POCC GB.ГБ05.B03231 Ambient temperature: -20°C to +50°C *See Special Conditions for Safe Use</p>	<p>GOST R 52350.0 GOST R 52350.1 GOST R 52350.11</p>	<p>N/A</p>	<p>Applicable</p>	<p>N/A</p>
 <p>Ex iad II CT4 GYJ011153X *See Special Conditions for Safe Use</p>	<p>GB3836.1 GB3836.2 GB3836.4</p>	<p>N/A</p>	<p>N/A</p>	<p>Applicable</p>

Table 4 Certifications and Approvals (continued)

SYMBOL	SPECIFIC DIRECTIVES, STANDARDS	MONROE, US FACTORY	SKELMER SDALE, UK FACTORY	SHANGHAI, CHINA FACTORY
<p>Note: This table indicates all applicable certifications and approvals on a factory basis. However, it does not mean that each individual device has all of the indicated certifications and approvals for that particular factory. Check your particular device for its certifications and approvals.</p> <p>*Special Conditions for Safe Use: The Protege is intended only for use with the charger/communication board, optional pump assembly, and optional Protege Multi-Charger.</p>				

General Safety Information

Ensure you adhere to the following for your safety.

Warning: *Read and follow the entire content of this guide prior to use. Failure to do so may result in serious injury or death.*



Warning: *All individuals who have or will have responsibility for using or testing this product must read and understand the contents of this manual. The product will perform as designed only if used and tested in accordance with the manufacturer's instructions. Failure to follow manufacturer's instructions will render the warranty and approvals null and void. Failure to follow these instructions may also result in serious injury or death.*

Scott Safety can take no responsibility for use of its equipment if it is not used in accordance with the instructions. If further operational or maintenance details are required but not provided in this guide, contact Scott Safety or their agent. Scott Safety shall not be liable for any incidental or consequential damages in connection with any modifications, errors or omissions in this guide.

All pertinent state, regional, and local safety regulations must be observed when installing and using this product. For reasons of safety and to assure compliance with documented system data, repairs to components should be performed only by the manufacturer.

Additionally, industry standards, codes, and legislation are subject to change. Updated copies should be obtained by users to ensure the most recently issued regulations, standards and guidelines are available.

All pertinent state, regional, and local safety regulations must be observed when handling and disposing of hazardous material, Toxic (E-Chem) Sensors, batteries and other similar items that may fall under the classification of hazardous material.

The Electrical, Electronic and Battery elements of this product must not be disposed of via municipal waste streams; they should be delivered to collection facilities. Information on collection facilities is given by the local authorities or importer's representative. Correct disposal will contribute to recycling of materials and prevent negative consequences for the environment.

For products sold in Europe, the end of life procedures for Battery operated Electronic products must comply with the RoHS Directive 2002/95/EC, the WEEE Directive 2002/96/EC and the Battery Directive 2006/66/EC. These directives dictate how to dispose of the electronic and battery elements of the product after use. For Protégé products sold in the UK only, Scott Safety Ltd has provided a collection service. This service can be accessed by Telephoning Customer Services on 01695 711711 who will be happy to assist. Please do not send products back to Scott. In other parts of Europe, other systems are in place. Please contact your local provider of Scott products for more details.

Only use Scott Safety approved replacement parts.

Warnings and Cautions – Device Use and Care

Ensure you follow the applicable warnings and cautions indicated here.



Warning: *This equipment must be operated and serviced by qualified personnel only. Read and understand the guide completely before operating or servicing. Qualified personnel as defined according to local, county, state, federal and individual company standards.*



Warning: *When in doubt vacate the area immediately. You should vacate the area immediately should the device indicate a warning or alarm condition. You should know, understand and follow your company's safety protocols.*



Warning: *Ensure the atmosphere is free from combustible and/or toxic gases prior to starting any of the procedures.*



Warning: *When the primary device is off line, ensure you have another online device to actively detect gases. The device may be off line due to such activities, like but not limited to, calibration, installation, maintenance, troubleshooting, configuration, wiring and other activities.*



Warning: *If the device does not function as described herein, remove from service and mark for maintenance. Only use Scott Safety replacement parts.*



Warning: *Only use the device to monitor the atmosphere for the gases and concentrations for which it is set-up to detect.*



Warning: *To prevent ignition of an explosive atmosphere, read and adhere to the manufacturer's live maintenance procedures.*



Warning: *Read this manual for intrinsic safety precautions. Substitution of components may impair intrinsic safety, resulting in serious injury or death.*



Warning: *To prevent ignition of a hazardous atmosphere, the device must be charged in an area known to be nonhazardous.*



Warning: *Pump activation is verified after the block pump, clear pump commands have been completed. Connecting a pump to the device when the device is already powered on requires pushing the left button to begin activation.*



Warning: *A high off-scale reading may indicate explosive concentration.*



Warning: *Perform a bump test every day. Failure to perform a daily functional test could lead to serious injury or death.*



Caution: *Device will not operate without power applied. Thus, it only detects gases while powered.*



Caution: *Periodically test for correct operation of the system's alarm events by exposing the device to a targeted gas concentration above the high alarm set point.*



Caution: *Calibration is critical. Calibration should be performed periodically that takes into account device use and environment conditions. Calibrate with known target gas at start-up and check on a regular schedule. The device should always be re-calibrated after exposure to high concentrations of toxic or combustible gases or vapors.*



Caution: *Verify the gas inlet ports are free of dirt and debris prior to use.*



Caution: *No gas detections are made while in the set-up mode.*



Caution: *Do not expose the detector to severe mechanical or electrical shock. Always conduct device startup and bump test procedures after such exposure to verify the device's operation and accuracy.*



Caution: *To ensure proper readings, do not operate the device within 1 to 2' of a high-powered portable radio. The radio keying results in reading fluctuations, as well as, alarm & vibration activations. If this does occur, perform a Bump Test of the device prior to putting back into service.*

Warnings and Cautions – Sensor Use and Care

Ensure you follow the applicable warnings and cautions indicated here.



Warning: *Extended exposure of the detector to high concentrations of toxic or combustible gases may result in degraded sensor performance. If an alarm occurs due to high concentration of combustible gases, exit to a safe area, then recalibrate the device or, if needed, replace the sensor.*



Warning: *The combustible sensor requires 10% oxygen in the atmosphere to operate. If you are unaware of the oxygen concentration or if the oxygen concentration is below 10% do not use the device to monitor for combustible gas concentrations. Failure to do so may result in injury and death.*



Caution: *Do not use any solvents, chemicals, or polishes containing silicon compounds to clean the detector as these can cause damage to the sensor.*



Caution: *Be aware of poisoned combustible sensors. The operation of catalytic type combustible gas sensors may be seriously affected by silicones, free halogens, halogenated hydrocarbons and metallic oxides present in the ambient air being monitored. If the presence of any of these substances is suspected, increased frequency of calibration verification is recommended.*



Caution: *Sensitivity of the combustible gas sensor can be adversely affected by exposure to sulfur compounds, halogens, silicone or lead containing compounds, or phosphorus containing compounds. Avoid exposure to these substances. Should the detector be suspected of being exposed to such substances, perform a gas test to verify its accuracy and that it is calibrated accordingly.*

Warnings and Cautions – Battery Use and Care

Ensure you follow the applicable warnings and cautions indicated here.



Warning: Do not attempt to charge the battery cells in potentially hazardous areas. Do not remove battery compartment, charge batteries, change batteries in anything but a known nonhazardous environment.



Caution: No attempt should be made to alter or repair the charger.



Caution: Do not attempt to replace the device's battery. Return to Scott Safety for replacement or repairs.



Caution: A fully discharged battery can lead to the loss of device's date and time resulting in the potential for erroneous event logging data. Recharge battery when warning displays.



Caution: Battery life (instrument run time) reduces at low temperatures.



Caution: Recharge battery pack as soon as the device indicates a low battery alarm.

Acronyms

Table 5 provides a quick reference for acronyms used in this guide that may be unfamiliar.

Table 5 Acronyms

ACRONYM	DEFINITION
AC	Alternating Current
CO	Carbon Monoxide
H ₂ S	Hydron Sulfide
ID	Inside Diameter
JRE	JAVA Runtime Environment
LCD	Liquid Crystal Display
LED	Light Emitting Device
LEL	Lower Explosive Level
O ₂	Oxygen
OD	Outside Diameter
PC	Personal Computer
ppm	Parts per million
RH	Relative Humidity
STEL	Short Term Exposure Limit
TWA	Time Weighted Average
USB	Universal Serial Bus

Chapter 1



Chapter Overview

This chapter covers the following topic:

- [Device Overview](#)

Device Overview

The Protégé comes with a long life rechargeable lithium-ion battery and sensors already installed and ready for use. The Scott Gas Monitor (SGM) software allows modification to the device's settings or capture data from the device once it is installed.

Depending on the sensors it is equipped with, the multi-gas personal device is designed for monitoring the atmosphere for potentially hazardous levels of combustible gases, oxygen enrichment or depletion, carbon monoxide, and hydrogen sulfide.

Gas indication displays via a direct reading backlit LCD, multiple bright LEDs, a loud audible alarm, and a vibratory alarm. The device includes a downloadable data log for up to 7000 events and records STEL / TWA / PEAK exposures, calibrations, and gas values. A built-in USB port on the charging module allows the device's data log to be downloaded and, when used with the device's SGM software allows you to quickly configure its operating and alarm parameters.

An optional Sample Draw Pump is available for remote sampling, an optional Masterdock Docking Station is available for performing automatic Bump Testing and Calibration, as well as an optional Multi-Charger that charges up to six (6) devices simultaneously. The optional Multi-Charger does not need to interface with a PC.

The device ships preconfigured and ready for operation using the factory default settings. However, you may want to reconfigure some of the parameters based upon your application. See [“Configuring the Scott Gas Monitor Software” on page 23](#).

If you have any questions about the device or its operation contact Scott Safety. See [“Assistance” on page 68](#).

[Figure 1](#) shows the major parts of the device.

Figure 1 Major Parts

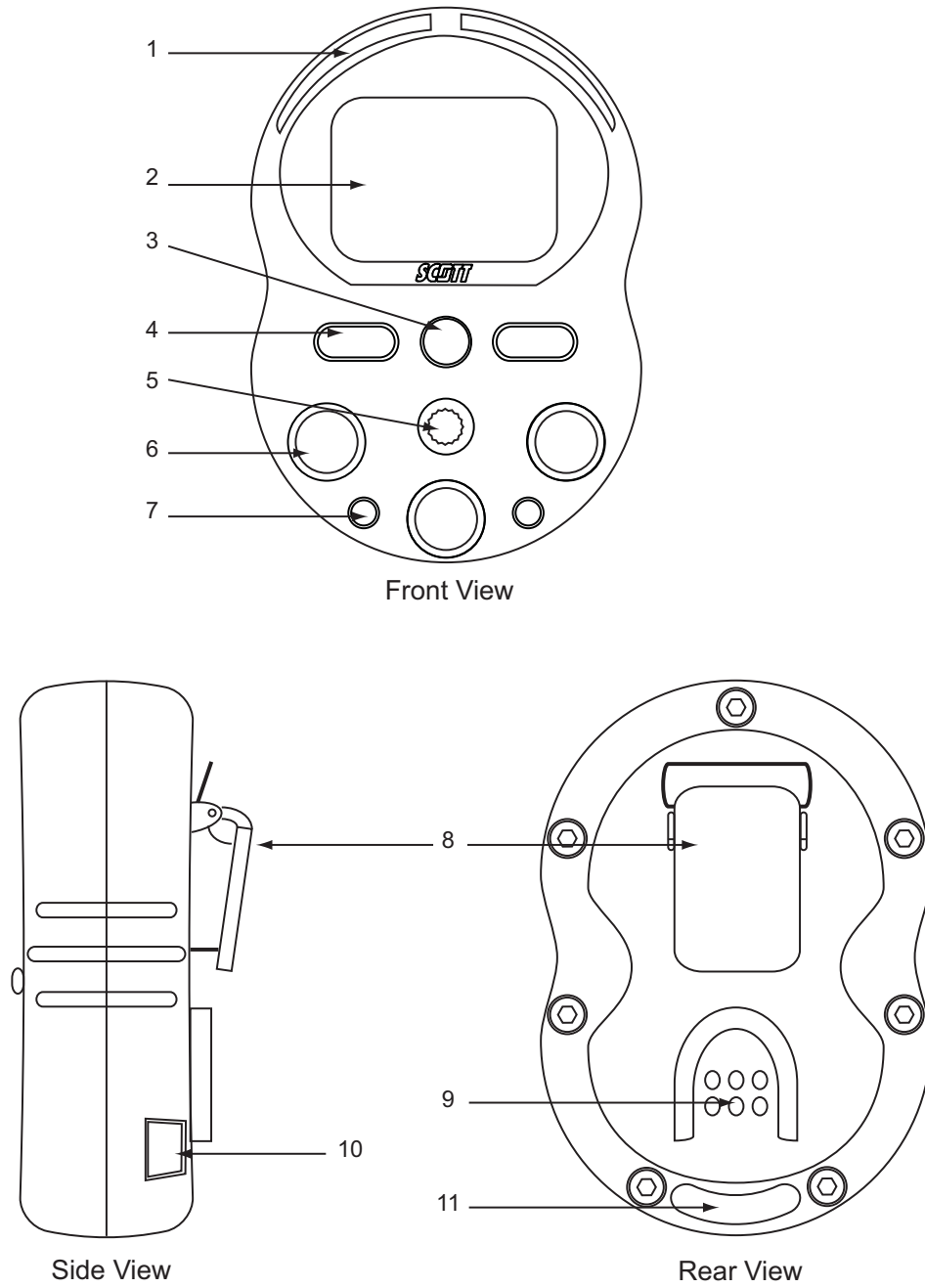

Table 6 lists the major parts of the device.

Table 6 Major Parts

REFERENCE NUMBER	ITEM
1	LED alarms (2)
2	LCD
3	Audible Alarm Port
4	Operation Button (2)
5	Threaded Port for Pump
6	Gas Inlet Port (3)
7	Power Contacts for Pump
8	Alligator Clip
9	Charge/Communication Shoe Pad
10	Calibration Adapter Receiving Pad
11	Pump Receiving Tab

Chapter 2



Chapter Overview

This chapter covers the following topics:

- [Planning for Installation](#)
- [Installation Checklist](#)

Planning for Installation

This section provides the pre-installation items.

Verifying Items Shipped

This section provides a list of the items that typically ship with the device. Ensure you have all items, if not See “Assistance” on page 68.

- Calibration Adapter
- Portable Gas Detectors CD
- T-8 Torx Driver

Downloading Software

This section describes how to obtain software.

The Scott Gas Monitor (SGM) proprietary software is a GUI that enables you to modify the device’s settings and access the data log.

The SGM software requires the installation of Sun Microsystems® JAVA Runtime Environment (JRE) software. If not previously installed on the PC, JRE can be installed on the PC after installation of the SGM software.

The SGM can be downloaded from our Web site:

- <https://www.scottsafety.com/en/us/Pages/Default.aspx>



The SGM also ships on the CD with the Device. Updates to the SGM are typically posted to our Web site first then to the CD.

The Sun Microsystems® JAVA Runtime Environment (JRE) software can be downloaded from this Web site:

- <http://www.java.com>

JAVA Version 5 or greater is required.



JRE 32-bit software is required to use the SGM on Windows 7 64-bit OS. Having JRE 64-bit software on your system is allowed, but not required.

Charging the Battery

This section describes how to charge the battery.



Caution: *The device’s battery must be charged prior to first use and daily after use. It will not operate without a battery or a battery in a low state of charge.*

The device is powered by a rechargeable lithium-ion battery. Typical run time is 18 hours with no pump and 12 hours with pump; however, alarming conditions reduces operating times. Typical charge time is between 4-6 hours. Verify battery is fully charged prior to use. Recharge battery pack as soon as the device indicates a low battery alarm.



Battery life varies depending on the device’s use, environmental conditions, and battery age.

Required items:

- The device
- AC Power Adapter
- Power & USB Communication Module



Warning: Do not attempt to charge the battery cells in potentially hazardous areas. Failure to do so could result in death or injury.

- 1 Plug-in the Power and USB Communications Module
- 2 Connect the device by sliding the connector Shoe into the device's pad. The device's LCD backlighting illuminates briefly and the battery charge indication icon begins to blink. The LCD indicates BATTERY CHARGED on the display when the battery is fully charged. Figure 2 shows the connections and screen displays.

Figure 2 Charging the Battery

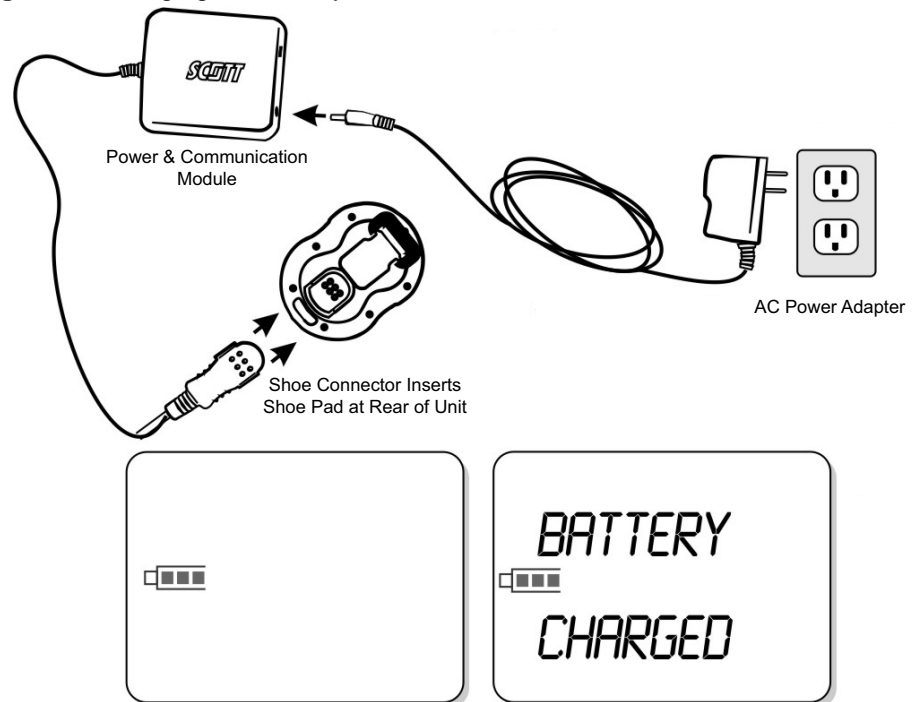

If a battery voltage becomes very low, the backlight illuminates when plugged into the charger, however, the battery charging icon may not appear right away.



A fully discharged battery can lead to loss of the device's DATE and TIME settings causing erroneous logging of gas events. If DATE and TIME are lost, See [“Configuring the Scott Gas Monitor Software”](#) on page 23.

Charging the Battery with the Multi-Charger (Optional)

This section provides information about charging the battery when using the optional Multi-Charger.

The Multi-Charger can be used to charge up to six (6) devices simultaneously. Unlike the single Power and USB Communications Module, the Multi-Charger does not need to be connected to a PC. Its only function is charging the devices.

To wall-mount the Multi-Charger (if desired), use two (2) screws (#8 or #10 Head) 6.0" (15.24cm) apart. Screws should not protrude greater than 0.25" (6.35mm). See [Figure 3](#).

Figure 3 Multi-Charger Mounting

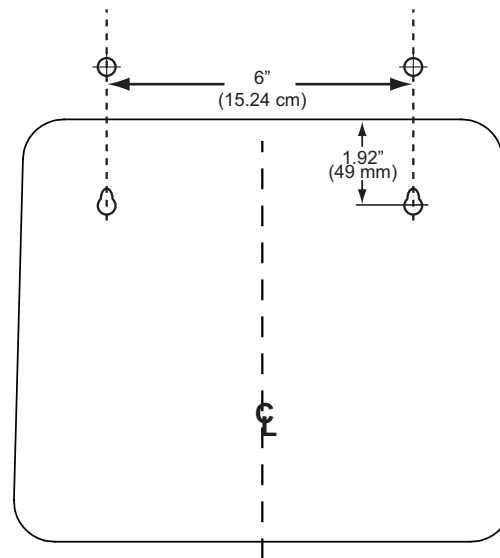

To use the Multi-Charger, connect the AC power source to bottom receptacle. Insert device with the alligator clip in the up position as shown on the front of the Multi-Charge (decal) and push the device to snap-insert in place. See [Figure 4](#).

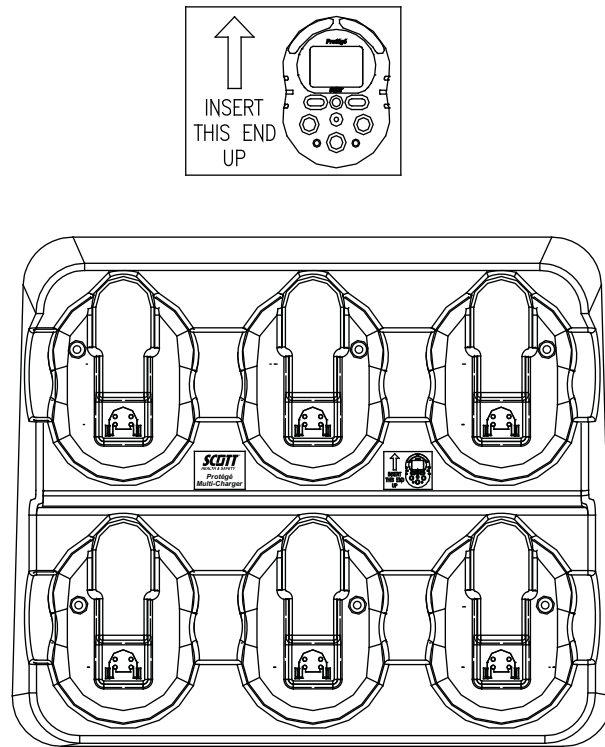
Figure 4 Multi-Charger Use

To clean the Multi-Charger, remove the devices and disconnect from power source. Use only a soft cloth to wipe surfaces. If necessary, a mild detergent may be used. Dry thoroughly before applying power or replacing devices. See [Figure 5](#).

Figure 5 Multi-Charger Cleaning

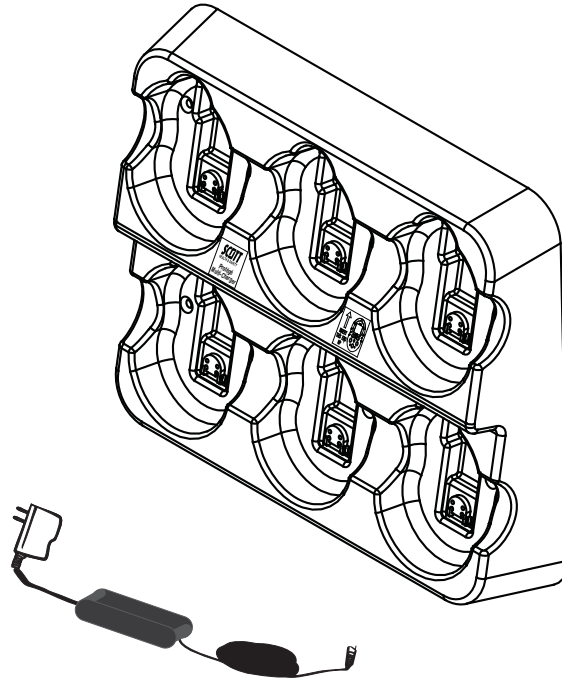

Installation Checklist

This section provides the installation requirements. [Table 7](#) lists the individual items.

Table 7 Installation Checklist

ITEM	DETAILS
SGM software	See “ Installing the SGM software ” on page 11.
JAVA Runtime Environment (JRE) software	See “ Installing the JAVA Runtime Environment (JRE) Software ” on page 15.
Optional Pump	See “ Installing the Optional Pump ” on page 17.

Installing the SGM software

This section describes the installation of the SGM.

The Scott Gas Monitor (SGM) software enables you to modify the device’s settings and access the data log.

The SGM software requires the installation of Sun Microsystems® JAVA Runtime Environment (JRE) software. If not previously installed on the PC, JRE can be installed on the PC after installation of the SGM software.

PC System Requirements:

- Operating Systems (OS): Microsoft Windows® XP, Microsoft Windows® Vista or Microsoft Windows® 7.
- JAVA Version 5 or greater
- USB port



All Windows OSs require administrator privileges to install SGM, and require power user privileges to run SGM.



Do not connect the device charger to the PC until after the (JRE) installation is complete.



For Windows Vista, perform [step 2](#) prior to beginning installation. For Windows 7 proceed to [step 3](#). For Windows XP proceed to [step 4](#).

- 1 Prior to installing a higher version of (SGM), ensure the lower version is removed. To remove lower version, select **Start > Control Panel > Add or Remove Programs > Scott Gas Monitor > Remove**.
- 2 For Windows Vista OS, navigate to USER ACCOUNTS AND FAMILY SAFETY using the control panel and proceed to remove USER ACCOUNT CONTROL (UAC). The check box must be unchecked for UAC. Restart the PC as necessary. See [Figure 6](#).
- 3 For Windows 7 OS, navigate to USER ACCOUNTS using the control panel and select CHANGE USER ACCOUNT CONTROL SETTINGS. Move the Selector to the NEVER NOTIFY (lowest level position). Then hit the OK button and next reboot your PC.

Figure 6 Windows Vista OS Only

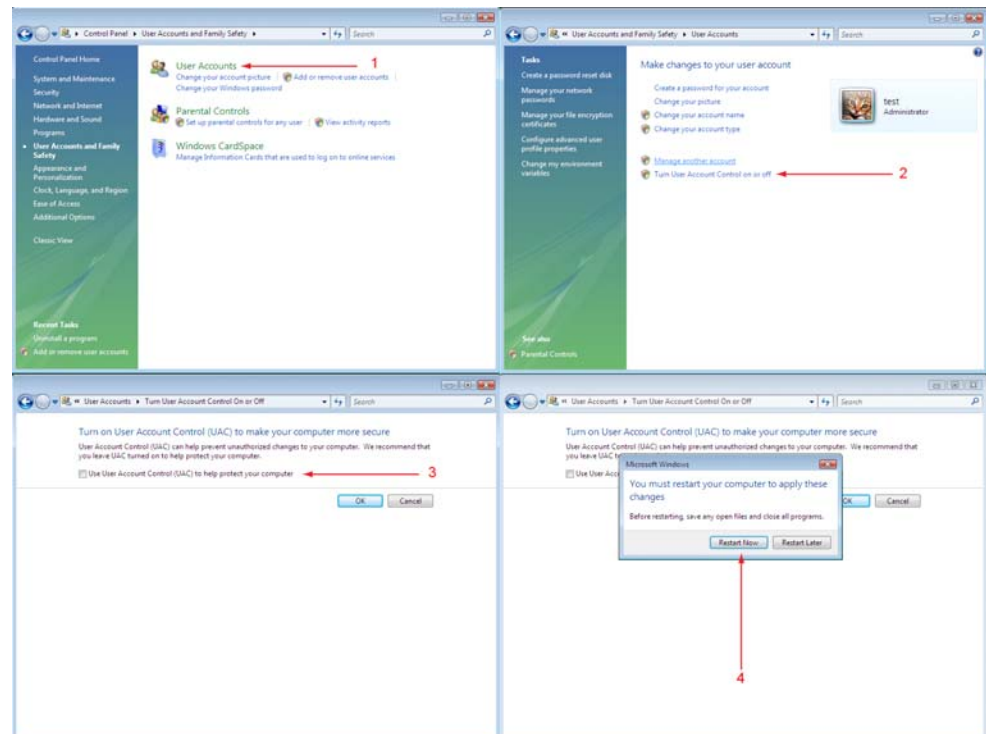

- 4 After downloading the SGM, navigate to the “gasmon.msi” file on the PC and double click it to start the installation procedure.
- 5 When prompted, click NEXT to proceed with installation. See [Figure 7](#).

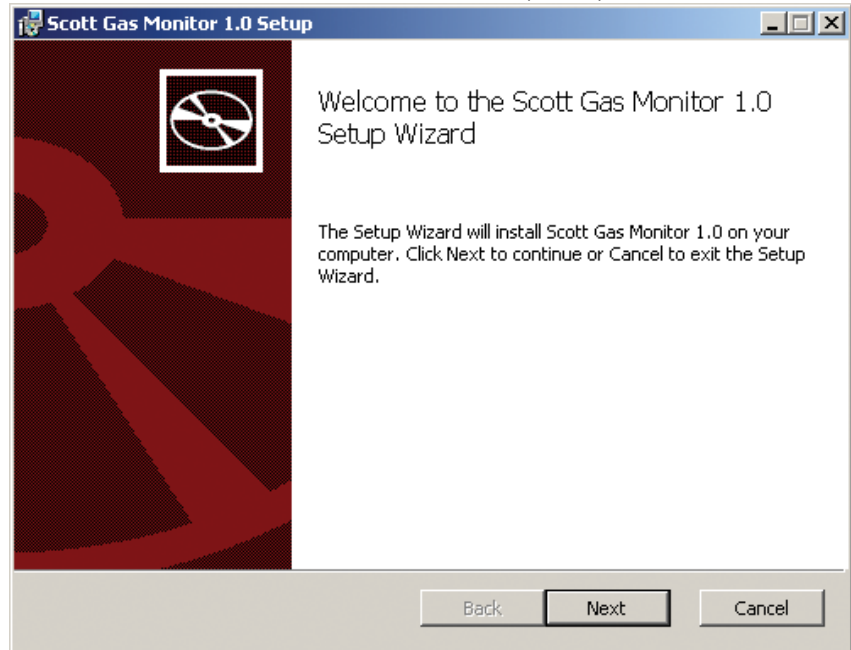
Figure 7 Scott Gas Monitor Software Installation (1 of 5)

- 6 When prompted, check the box to accept the terms of the License Agreement. Click NEXT to proceed. See [Figure 8](#).

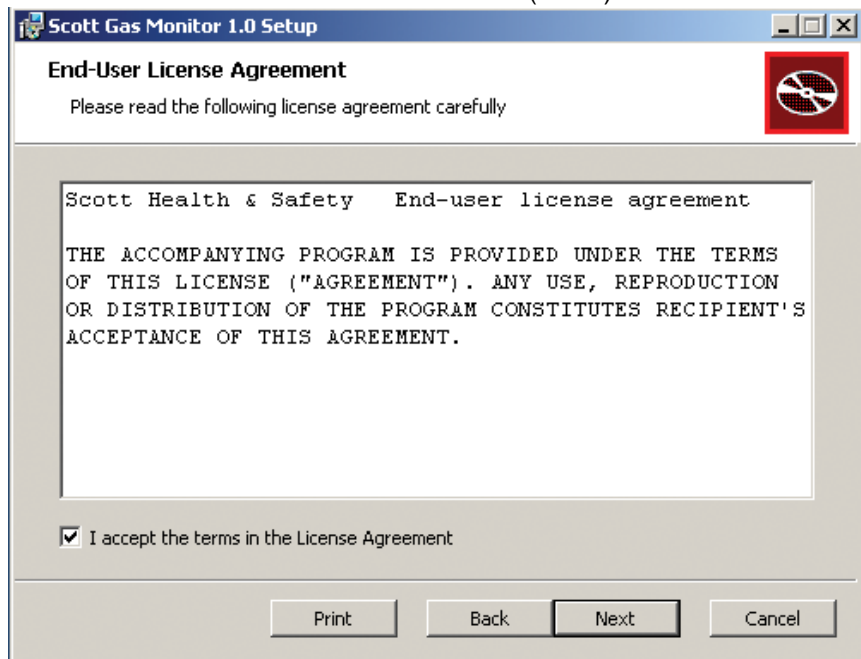
Figure 8 Scott Gas Monitor Software Installation (2 of 5)

- 7 If desired, select a custom location to install the SGM software or use the default location. Click NEXT to proceed. See [Figure 9](#).

Figure 9 Scott Gas Monitor Software Installation (3 of 5)

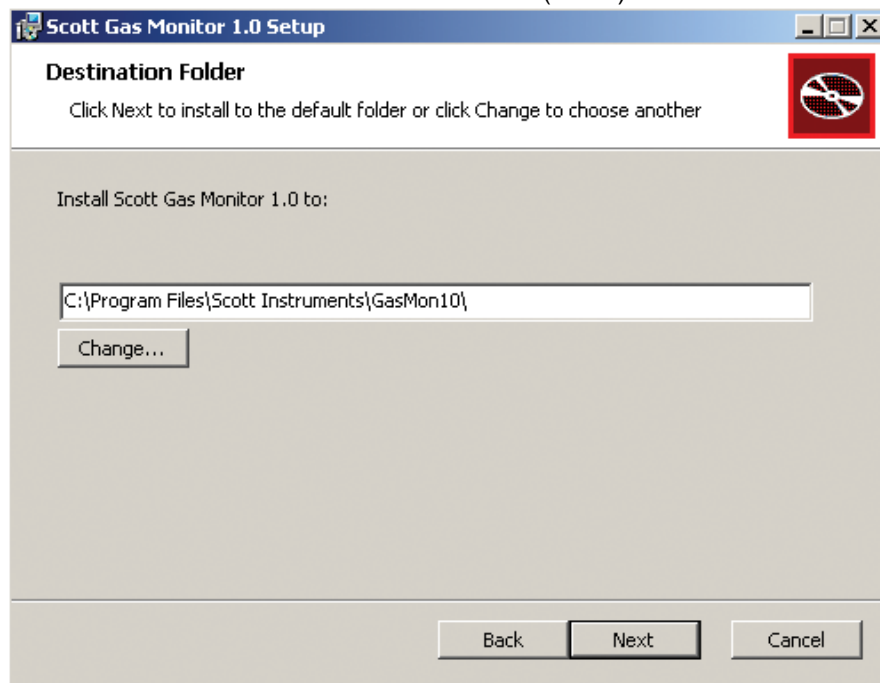

8 Click INSTALL and monitor installation progress. See [Figure 10](#).

Figure 10 Scott Gas Monitor Software Installation (4 of 5)

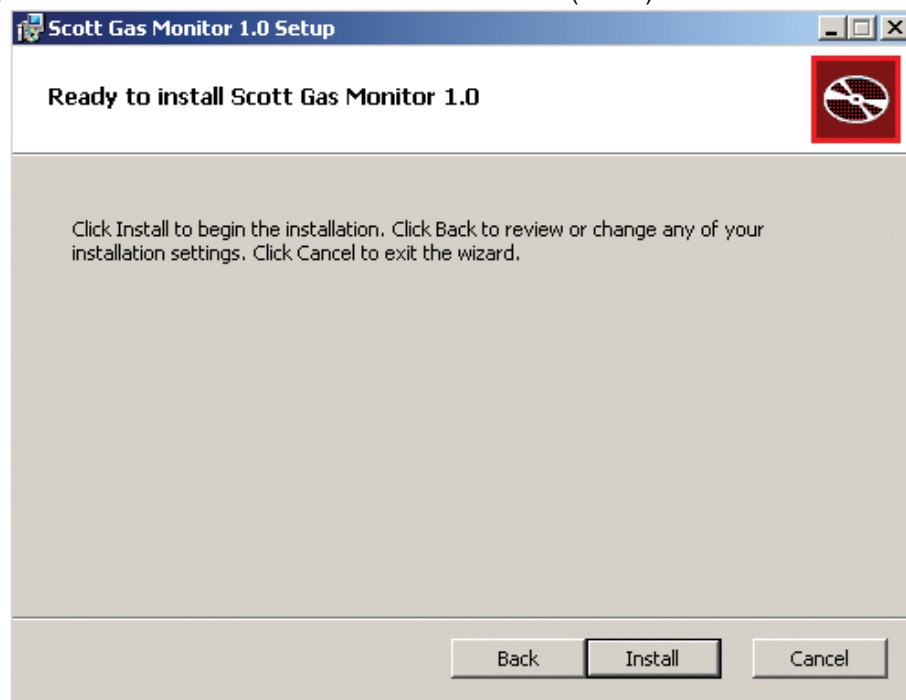

- 9 When prompted, click FINISH to complete the installation. See [Figure 11](#).

Figure 11 Scott Gas Monitor Software Installation (5 of 5)



Installing the JAVA Runtime Environment (JRE) Software

This section describes the installation of the JRE.

JAVA Runtime Environment (JRE) software must be installed to use the SGM software.



JRE 32-bit software is required to use the SGM on Windows 7 64-bit OS. Having JRE 64-bit software on your system is allowed, but not required.

- 1 Navigate to the Java folder and select the JAVA installation file for the appropriate operating system of the PC.
- 2 Double click the file to begin the installation process.
- 3 Observe the JRE installation begins. Installation files may be unpacked during an automated process.
- 4 When prompted, select ACCEPT to agree to the User License Agreement and proceed with the installation. See [Figure 12](#).

Figure 12 JAVA JRE Software Installation (1 of 3)



- 5 When prompted, either check (select) or un check (un select) any of the third party software applications, such as Google Tool bar, that Sun Microsystems provides bundled with the JRE software installation. See Figure 13.

Figure 13 JAVA JRE Software Installation (2 of 3)

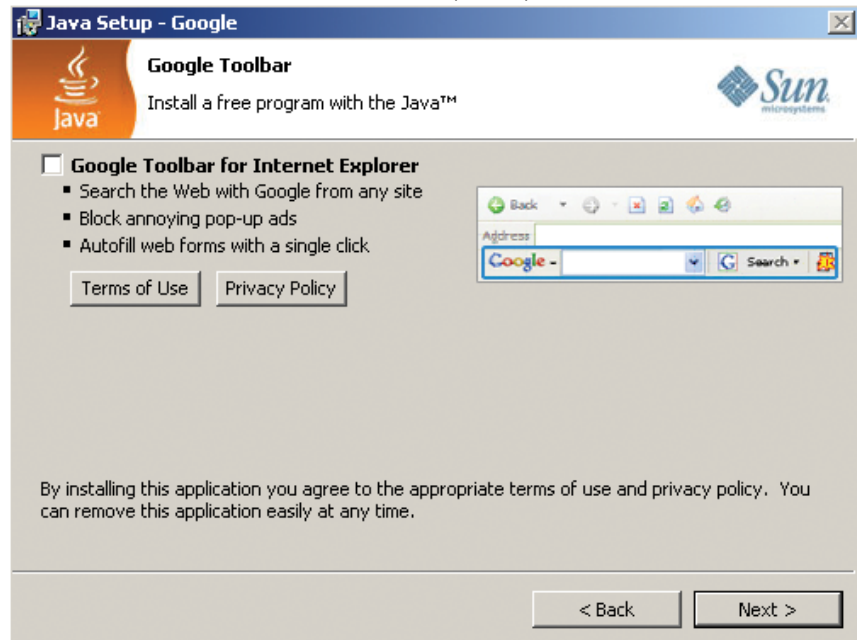

Only JRE software is required to run the SGM software. Installing or not installing any optional software on this screen will not affect operation of the SGM.

- 6 Click NEXT to proceed.

- 7 Observe the installation progress screen through the installation. The Installation times varies depending on PC performance.
- 8 When prompted upon successful completion of the JRE software installation, click FINISH to complete the installation. See [Figure 14](#).

Figure 14 JAVA JRE Software Installation (3 of 3)

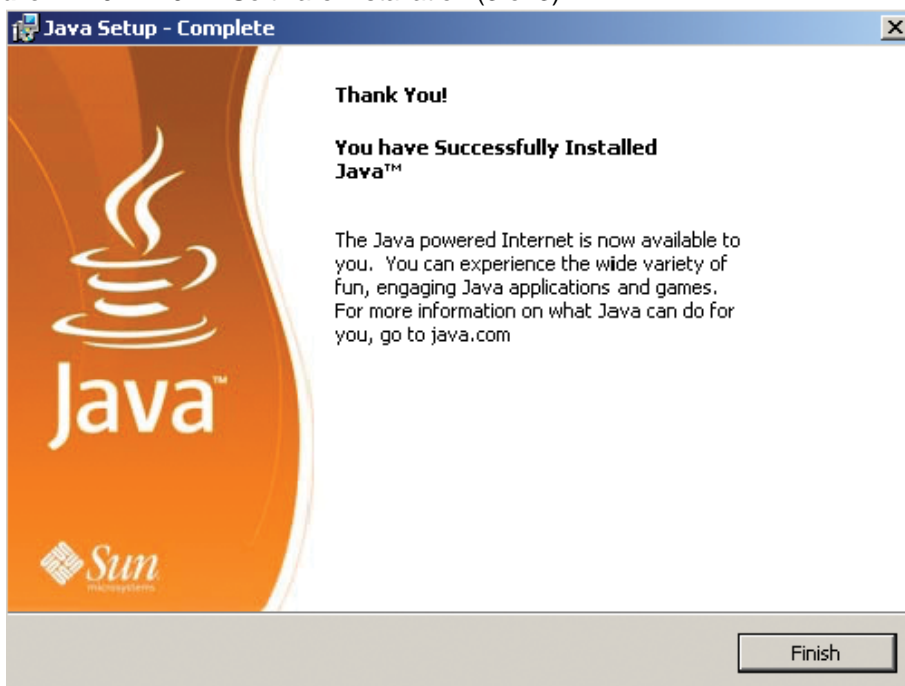

Installing the Optional Pump

This section provides information on installing the optional pump when powered up or powered down and disconnecting.

The device's Automatic Sample Draw Pump is powered by the device's internal battery. Typical run time with pump is 12 hours; however, environmental conditions and alarm conditions shorten run time. If the pump is connected to the device when the device is powered up, it is automatically recognized.

Scott Safety recommends using the pump only when the tubing and sample draw system including hydrophobic and particulate filters in the probe assembly are attached to avoid possible contamination of the pump.

To troubleshoot a poorly performing pump, See [“Troubleshooting the Device” on page 51](#).

Required items:

- The device
- Optional Pump



Caution: When using the sample draw pump, allow sufficient sample time based on the length of sample tubing you are using. Allow a minimum of 1 second for every foot of sample tubing and wait for the gas readings to stabilize. Failure to do so could lead to inaccurate readings.

Installing - Device Powered Down

This section describes how to install the optional pump when the device is powered down.

- 1 Connect the pump by inserting, at an angle, the pump's back Tab into the device's Tab. Rotate the pump forward until the pump sits flush with the device. Tighten the Thumb Screw into the threaded hole located on the front of the device. See [Figure 15](#).

Figure 15 Pump Installation

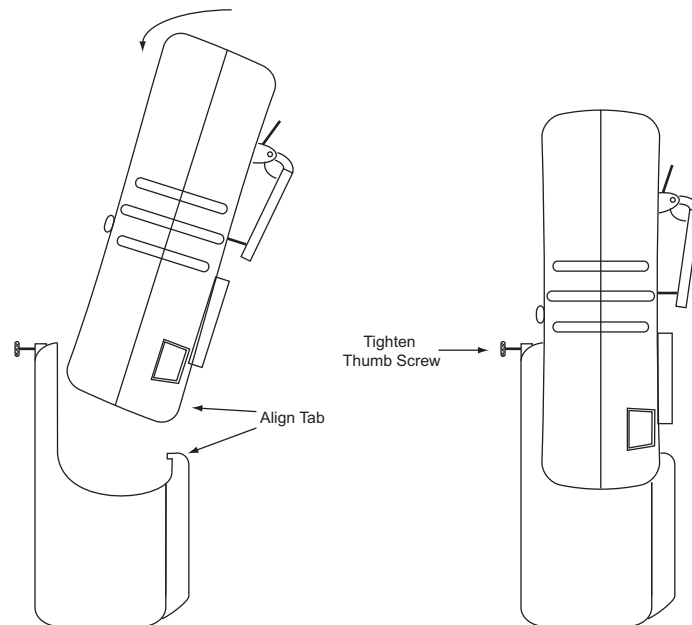

- 2 Power on the device and allow it to run through its start-up routine. At this point, the pump is running.
- 3 Upon completion of the start-up routine, the pump activates and BLOCK PUMP displays. To block pump inlet, place a finger over the probe. Once the test is passed, CLEAR PUMP displays. See [Figure 16](#).

Figure 16 Pump Displays - Start Up

If the device fails to indicate clear pump, check for any potential leaks in the connection of the pump to the device or within the sample draw system including hydrophobic and particulate filters in the probe assembly.

- 4 Remove finger from probe and the device is ready for use.

Installing - Device Powered Up

This section describes how to install the optional pump when the device is powered up.



Warning: *Pump is not automatically activated when attached to a powered on device. You must press the Left Operation Button to begin pump activation. Failure to activate a pump leads to unreliable monitoring that could lead to death or injury.*

- 1 Connect the pump by inserting, at an angle, the pump's back Tab into the device's pump receiving Tab. Rotate the pump forward until the pump sits flush with the device. Screw the pump retaining screw into the threaded hole located on the front of the device. See [Figure 15](#).
- 2 At this point, the pump is not running. Push and hold the Left Operation Button to activate the pump. Release the Left Operation Button when BLOCK PUMP displays.
- 3 To block pump inlet, place a finger over the probe. Once the test is passed, CLEAR PUMP displays.



If the device fails to indicate CLEAR PUMP, check for any potential leaks in the connection of the pump to the device or within the sample draw system including hydrophobic and particulate filters in the probe assembly.

- 4 Remove finger from probe and the device is ready for use.

Disconnecting the Optional Pump

This section describes how to disconnect the optional pump from the device.

- 1 Unscrew the pump retaining screw while continuing to hold the pump against the device.
- 2 If unit is powered on, press and hold the Left Operation Button until the device starts displaying the PEAK exposures.



If the pump alarm sounds, acknowledge by pressing and releasing the Left or Right Operation Button, then press and hold the Left Operation Button until the device starts displaying PEAK EXPOSURES. PEAK EXPOSURES flashes briefly before returning to a normal monitoring display.

- 3 Rotate the pump backwards until it comes off the device.

Chapter 3

SCOTT CONFIGURATION AND SETUP

Chapter Overview

This chapter covers the following topic:

- [Configuration and Setup Checklist](#)

Configuration and Setup Checklist

This section provides the configuration and setup requirements. [Table 8](#) lists the individual items.

Table 8 Configuration and Setup Checklist

ITEM	DETAILS
Device to PC connection	See “ Connecting the Device to a PC ” on page 22.
SGM software	See “ Configuring the Scott Gas Monitor Software ” on page 23.
SGM software (defaults)	See “ SGM Defaults ” on page 27.

Connecting the Device to a PC

This section describes connecting the device to a PC.

Required items:

This assumes you have already installed both the SGM and JAVA JRE software.

- The device
- A PC
- USB Cable
- Power & USB Communications Module
- AC Power Adapter

- 1 Start the SGM software by double-clicking the Protégé PCI icon. The icon is loaded onto the Desktop during a typical install of the SGM software. The Protégé PCI icon may be located in another location if a custom installation was performed. See [Figure 17](#).

Figure 17 Device Icon



- 2 Connect the AC Power Adapter cable to the Power & USB Communications Module, connect the USB cable to the Power & USB Communications Module, and connect the USB cable to your PC USB cable port.



If this is the initial install of the Power & USB Communications Module, allow the PC to load and recognize the Power & USB Communications Module before proceeding.

- 3 Connect the device to the Power & USB Communications Module by sliding the connector shoe into the back of the device. See [Figure 18](#).

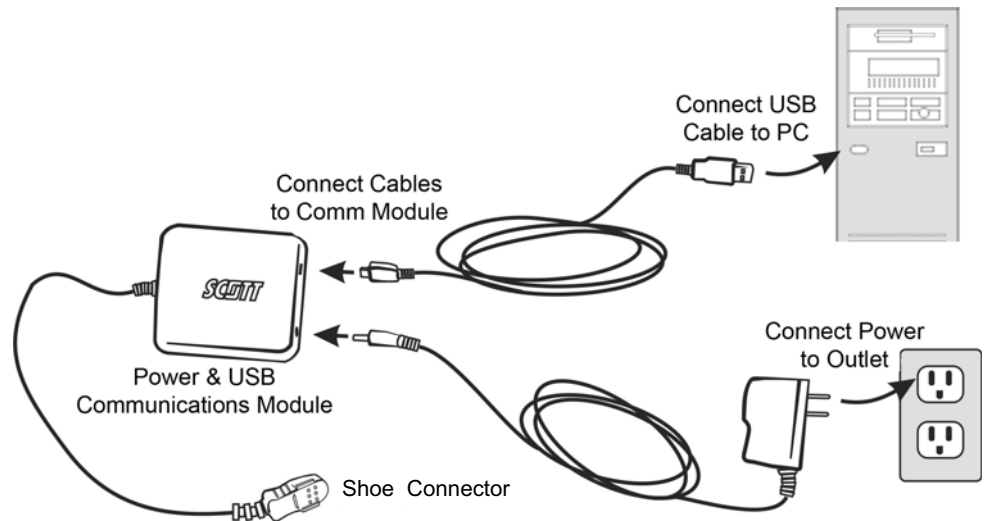
Figure 18 Connecting the Device to a PC

- 4 The SGM software confirms connection between the PC and the device via the HOME tab. CONNECTED or PLEASE CONNECT YOUR INSTRUMENT displays underneath the picture of the device.

Configuring the Scott Gas Monitor Software

The SGM software provides a PC interface to the device to download the data log, adjust settings, and establish alarm set points. Navigation of the software is accomplished using the PC mouse and keyboard. The four (4) tabs located at the top of the SGM are described here:

- Home – Tab is the default screen that appears when starting the SGM software. You may select the language to display and see the status of the connection to the device from this tab.
- Settings – Tab is used to change alarm settings. Tab provides a number of different options. Alarm set points can be changed, a password can be inserted, timers can be defined and the length of the LCD backlight can be configured.
- Set Clock – Tab is used to set the date and time of the device. There is an option to synchronize the time of the device with the PC for accurate time keeping ability.
- View Log – Tab does not have any configurable options. Use it to download log data from the device. This data can be read, saved, cleared, and recalled from previously saved files.

The device ships preconfigured and ready for operation using the factory default settings. However, you may want to reconfigure some of the parameters based upon your application. [Table 9](#) provide the default settings and ranges for the SGM's five (5) items under Settings. See "[SGM Defaults](#)" on [page 27](#).

[Figure 19](#) shows the Home Tab screen.

Figure 19 Scott Gas Monitor (SGM) Software Home Screen



Figure 20 shows the Settings Tab screen.

Figure 20 Scott Gas Monitor (SGM) Software Settings Screen

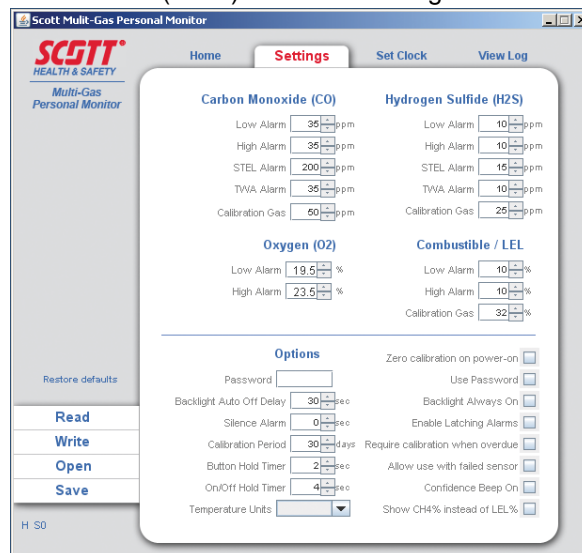

The following options are available:

- Restore Default – Restores all device settings to the factory default.
- Read – Uploads current device settings for review or modification.
- Write – Downloads parameter changes made within the SGM software to the connected device.



Changing settings within the SGM software does not change the settings on the device until write has been accomplished.

- Open – Opens and displays previously saved device parameter setting profiles.
- Save – Saves device parameter setting profiles.

- CO, H₂S, O₂, and Combustible/LEL – Use the up and down arrows to adjust set points for each alarm as desired.
- Options – Provides the following items:
 - Password – A 4-digit password may be used to limit entry into the Span calibration of the device. Select the check box that says USE PASSWORD and enter a 4-digit number into the box. Once written to the device, everyone who attempts to Span calibrate the device must enter this password. The default setting is unchecked.
 - Enable Latching Alarms – When checked, this option requires you to acknowledge all alarms even when the target gas concentration returns to a non-alarm concentration level. The default setting is unchecked.
 - On/Off Hold Timer – Sets the required time in seconds for you to hold the Operation Buttons when powering on and off the device. The default setting is 4 seconds.

Figure 21 shows the Set Clock Tab screen.

Figure 21 Scott Gas Monitor (SGM) Software Set Clock Screen

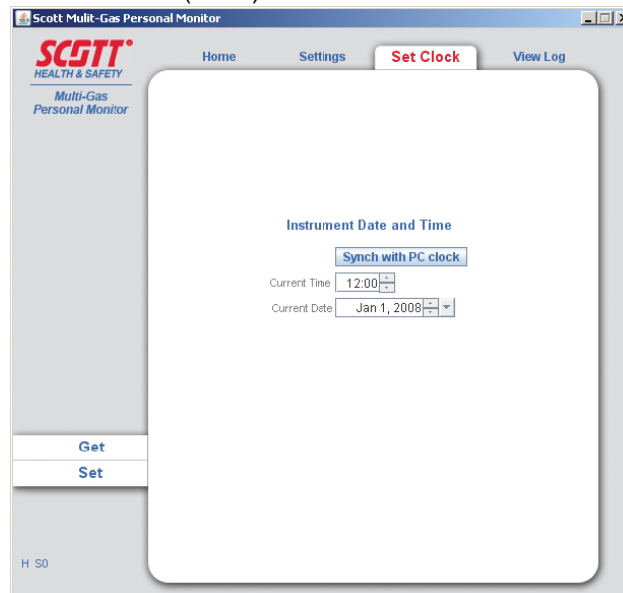

The following options are available:

- Synch with PC Clock – Allows you the option to synchronize the device's internal clock with the PC clock.
- Get – Reads the time setting of the device presently connected and displays it on the SGM Set Clock dialogue box.
- Set – Uploads the time displayed on the SGM Set Clock dialogue box to the device presently connected.

SGM Defaults Table 9 provides the default settings and ranges for the SGM's five (5) items under Settings.



Warning: Use of the Allow Use with Failed Sensor option is discouraged. Operating the device with a failed sensor will not provide full monitoring capabilities. Use this option only after careful consideration and understanding of the device's reduced monitoring capabilities and following local regulations. Failure to understand how operating the device with a failed sensor may lead to death or injury.

Table 9 SGM Defaults

ITEM	SUB ITEM	RANGE	FACTORY DEFAULT
Carbon Monoxide	CO Low Alarm	0 to 500ppm	35ppm
	CO High Alarm	0 to 500ppm	35ppm
	CO STEL Alarm	0 to 250ppm	200ppm
	CO TWA Alarm	0 to 100ppm	35ppm
	CO Calibration Gas Concentration	0 to 999ppm	50ppm
Hydrogen Sulfide	H ₂ S Low Alarm	0 to 200ppm	10ppm
	H ₂ S High Alarm	0 to 200ppm	10ppm
	H ₂ S STEL Alarm	0 to 15ppm	15ppm
	H ₂ S TWA Alarm	0 to 15ppm	15ppm
	H ₂ S Calibration Gas Concentration	0 to 500ppm	25ppm
Oxygen	O ₂ Low Alarm	0 to 25%	19.50%
	O ₂ High Alarm	0 to 25%	23.50%
Combustible	LEL Low Alarm	0 to 60%	10% LEL
	LEL High Alarm	0 to 60%	10% LEL
	LEL Calibration Gas Concentration	0 to 70%	32% LEL

Table 9 SGM Defaults (continued)

ITEM	SUB ITEM	RANGE	FACTORY DEFAULT
Options	Password		1234
	Backlight Auto Off/Delay	0-255secs	30secs
	Silence Alarm	Yes/No	No
	Calibration Period	1-180days	30days
	Button Hold Timer	1-4secs	2secs
	On/Off Hold Timer	0-9secs	2secs
	Temp Units	Fahrenheit/ Celsius	Fahrenheit
	Zero Calibration on Power-on	On/Off	Off
	Use Password	Yes/No	No
	Backlight Always On	Yes/No	No
	Enable Latching Alarms	Yes/No	No
	Require Calibration when Overdue	Yes/No	No
	Allow Use with Failed Sensor (See WARNING above.)	Yes/No	No
	Confidence Beep On	Yes/No	No

Chapter 4



Chapter Overview

This chapter covers the following topics:

- [Operating the Device](#)
- [Powering Up](#)
- [Powering Down](#)

Operating the Device

This section describes the operational modes of the device. Primary User Interface (UI) of the device is via the LCD. During operation, the LCD displays continuous data on gas concentrations and alarm conditions. Additionally, you can monitor peak values of gas concentrations.

At start up, the LCD shows current alarm set points for each sensor installed, current date and time, software version installed, and when the next required calibration is due.



Warning: If Protégé fails to respond properly upon start up, or if calibration is out of date, do not use the device until it has been properly serviced or calibrated. Failure to do so could result in death or injury.

Figure 23 shows the LCD items.

Figure 23 LCD Indicators

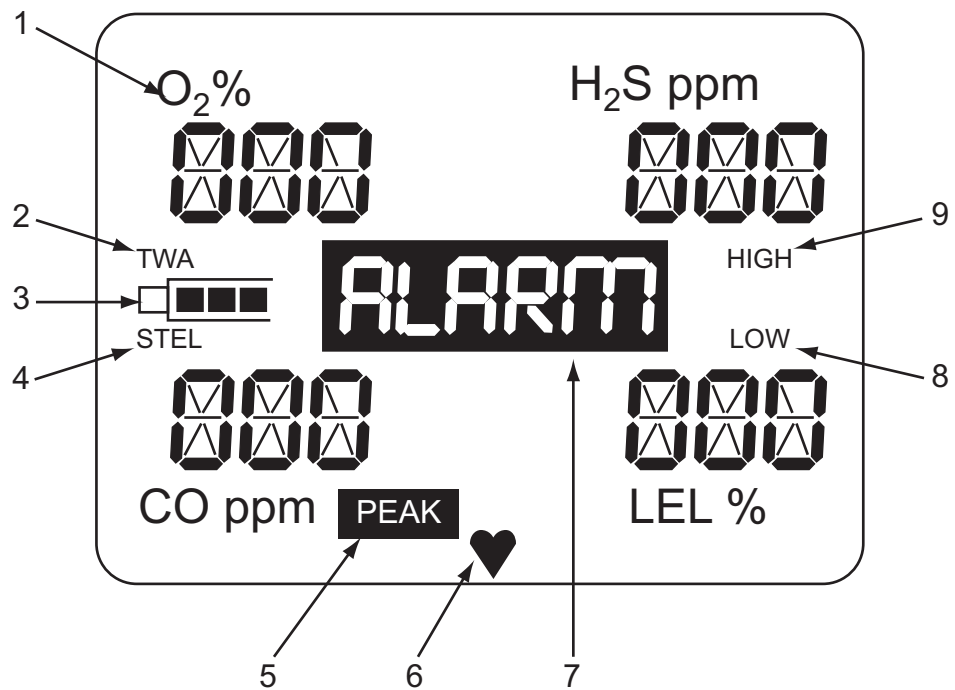

Table 10 lists the LCD items and their descriptions.



Warning: If device does not operate in the manner described here, do not use. Tag it out of service. Failure to ensure it is properly operating may result in serious injury or death.

Table 10 LCD Items and Descriptions

REFERENCE NUMBER	ITEM	DESCRIPTION
1	Gas Type Label	Indicates the type gas being detected. Label blinks if an alarm.
2	TWA	Indicates TWA displayed when alarm set points have been reached.
3	Battery Charge	Battery charge depletion is indicated as bars disappear to the left.
4	STEL	STEL displayed when STEL alarm set points have been reached.
5	PEAK	Indicates highest gas exposure encountered since turning on the instrument for Combustible (LEL) and Toxic (E-Chem) sensors; and high and low value for oxygen sensor. Press and release the Left Button to view.
6	Heart Beat	Blinks to indicate device is in monitoring mode. Note: Will not blink during start-up routine or calibration.
7	Alarm	Displays when alarm set points have been reached.
8	Low Alarm	Indicates low alarm point settings or when low alarms point reached.
9	PUMP	Displays when pump is activated.
10	High Alarm	Indicates high alarm point settings or when high alarms point reached.

LCD Alerts and Displays

This section describes various alerts and displays.

- Gas Warning and Alarm Alerts:
 - Both gas warnings and alarms blink the specific gas type that is in alert. Audible, visual, and vibrating alarms activate and the concentration/value of the sensor in alarm is indicated.
 - If a Gas Type Label blinks with no alarm present, the sensor is detecting a negative drift. Perform a Zero Calibration to clear the drift. See [“Zero Calibration” on page 39](#).
 - If the option to Allow Use with Failed Sensors is enabled using the SGM software, the device displays FAL in place of the reading for that particular sensor.



Warning: *The option of Allow Use with Failed Sensors is discouraged. Operating the device with a failed sensor will not provide full monitoring capabilities. Use this option only after careful consideration and understanding of the device’s reduced monitoring capabilities and following local regulations. Failure to understand how operating the device with a failed sensor may lead to death or injury.*

- Low Battery – The battery charge icon blinks and the device activates the visual, audible, and vibratory alarms when a battery becomes low. Low battery conditions can be silenced by pressing the left Operation Button. You should immediately exit the environment and charge the device as soon as a low battery alarm is indicated.

- Over-Range Conditions – If a sensor within the device is exposed to a target gas concentration that exceeds the sensor’s range, the device activates its visual, audible, and vibratory alarms and displays +++ at the sensor’s location on the LCD. Alarm conditions clear when the gas concentration has subsided.



Warning: *If an over-range condition is encountered, perform a bump test as soon as safely possible to ensure device functionality. If the device fails the Bump Test, perform a full calibration procedure. Failure to do so could result in inaccurate monitoring by the device and cause death or injury.*



Warning: *If using the device with a failed sensor, the failed sensor reading will be wrong, cannot be relied upon and the device should be replaced at the earliest possible moment.*

- Low Flow Pump Warning – Displays when airflow through the pump is diminished or restricted and could compromise accurate readings. Device shuts down the pump and the device goes into audible, visual, and vibratory alarm while the PUMP icon flashes. After the cause of the low pump flow is cleared, reset the pump by pressing and releasing the Operation Button (Left or Right).
- Sensor Failures – FAL indicates each sensor that fails to Zero or Span Calibrate. Should this occur, recalibrate the device. If a sensor continues to fail, replace the sensor and recalibrate or contact an authorized service center.

Powering Up

This section describes the power up sequence.



Warning: *If the device does not operate in this fashion, do not use. Tag it out of service. Failure to do so may result in serious injury or death.*

- 1 Press and hold **one** (1) of the two Operation Buttons (Left or Right) until the countdown timer has completed and RELEASE displays on the LCD. If the Operation Button is held for 5 seconds after RELEASE displays the device will not turn on. See [Figure 24](#).

Figure 24 Power Up Buttons

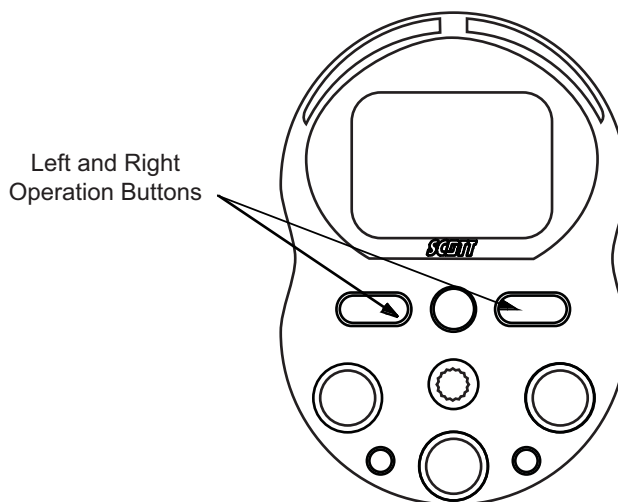

If battery voltage becomes very low while powered off, the device may display PLEASE CHARGE when attempting to power on device. Always fully charge battery prior to use.



The countdown timer parameter varies as set using the SGM software. See “[Configuring the Scott Gas Monitor Software](#)” on page 23.

The device starts its Power-Up Self Test Sequence once the Operation Buttons release. This sequence consists of the following:

- 1 LED, vibrating, and Audible Alarm Check – All LED’s are lit, audible alarm is sounded, and vibrating alarm is activated.
- 2 Software - The current version displays.
- 3 Date displays.
- 4 Time displays.
- 5 Low Alarm settings display.
- 6 High alarm settings display.
- 7 STEL alarm setting displays.
- 8 TWA alarm setting displays.

9 Cal Due – Indicates when next calibration is due in days.



Warning: Operating a device that has exceeded its calibration date can cause false readings of detected gases. Do not trust invalid readings obtained while device is out of calibration. Operating a device that is out of calibration may not accurately indicate environmental conditions which can lead to death or injury.



Warning: If CAL EXPIRED is displayed upon power on start up sequence indicating the device does not have valid current calibration, press the Right Operation Button to override and immediately calibrate the device. A device that has not been properly calibrated can lead to death or injury.



Warning: Never operate the device in gas monitoring mode with the calibration adapter attached. This can cause false readings of detected gases. Failure to do so can lead to death or injury.

After this sequence is complete, the device resumes typical monitoring.

Powering Down

This section describes the power down sequence.

- 1 Press and hold **both** Operation Buttons (Left and Right) simultaneously until the countdown timer completes and the LCD is blank.

When the Operation Buttons are held for 5 seconds after the LCD goes blank, the device attempts to power back on.



The timing parameter varies as set using the SGM software. See [“Configuring the Scott Gas Monitor Software”](#) on page 23.

Chapter 5



Chapter Overview

This chapter covers the following topics:

- [Calibrating the Device](#)
- [Maintaining the Device](#)
- [Troubleshooting the Device](#)

Calibrating the Device

This section covers calibration of the device.



Warning: Operating a device that has exceeded its calibration date can cause false readings of detected gases. Readings obtained while device is out of calibration are invalid and could lead to death or injury.



Caution: If CAL EXPIRED displays upon power on start up sequence indicating the device does not have valid current calibration, press the right operation button to override and immediately calibrate the device. Failure to do could result in inaccurate monitoring by the device sensors.

Scott Safety recognizes the potential of the device as a life saving device when operated and maintained correctly. As such, verifying proper operation of the device in the form of Span Calibration and daily Bump Testing is essential to ensure the device performs as intended in a potentially hazardous environment.

The frequency at which Span Calibration and Bump Testing occur is best determined based on local regulatory standards, company policies, and industry best practices. Scott Safety is not responsible for setting policies or practices.

Calibration and Test methods include the following:

- Zero Calibration — Is performed to establish baseline readings of atmospheres that are known to be free of toxic or combustible gases.
- Span Calibration — Is performed to ensure the device detects target gases within specified operating parameters. Span Calibration is the adjustment of the device's response to match a known concentration of gas. Sensors can lose sensitivity through normal degradation, exposure to high gas concentrations, or sensor poisoning. Accurate calibration can be achieved only if specific concentrations of the correct gases are used. Span Calibration should be performed when a new sensor is installed or when the device displays CAL EXPIRED. Span Calibration must be performed anytime a daily Bump Test fails.
- Bump Testing — Verifies the Span Calibration by subjecting the device to a known exposure of gas, verifying the response is within +/-20% of actual concentration and verifies that all alarms work properly. Scott Safety recommends the following:
 - A daily Bump Test be performed prior to each day's use and whenever the sensor has been exposed to a high gas concentration, submerged in water, or exposed to mechanical shock such as being dropped.
 - A daily Zero Calibration be performed prior to each day's use and when the device displays a reading other than its baseline reading in an atmosphere known to be free of any toxic or combustible gases. When an atmosphere is not known to be free of toxic or combustible gases, a Zero Air calibration cylinder may be used.

Table 11 details the recommended calibration and test items for the device.

Table 11 Recommended Calibration and Test Matrix

ITEM	FREQUENCY	DETAILS
Zero Calibration	<ul style="list-style-type: none"> Daily When baseline readings are incorrect or suspect Prior to a Span Calibration 	See “Zero Calibration” on page 39.
Span Calibration	<ul style="list-style-type: none"> CAL EXPIRED is displayed After installing new sensors When a Bump Test fails 	See “Span Calibration” on page 40.
Bump Test	<ul style="list-style-type: none"> Daily When a sensor is exposed to a high concentration of gas When submerged in water When exposed to mechanical shock, such as being dropped 	See “Bump Testing” on page 43.

Zero Calibration This section describes how to perform Zero Calibration.

- 1 Verify ambient air is free of toxic or combustible gases. If air is not free or cannot be verified free, obtain a Zero Air gas cylinder.
- 2 Power on the device.
- 3 Press and hold the Right Operation Button until PLEASE WAIT displays. It is in progress. See [Figure 25](#).

Figure 25 Zero Calibration Display - In Progress

Warning: To prevent an erroneous Zero Calibration from occurring, the device displays IS AIR CLEAR? If the device is indicating a gas reading that is 50% or higher of an alarm set point for any of the gases it is equipped to detect. You have 20 seconds to acknowledge the alert. If the alert is not acknowledged within 20 seconds, the device powers off. Do not continue with Zero Calibration until air has been verified free of toxic and combustible gases. Failure to properly perform a zero calibration may result in injury or death.



Baseline readings for a Zero Calibration are 0 for H₂S, CO, and LEL, and 20.9% for O₂.

- 4 If display indicates IS AIR CLEAR?, and atmosphere has been verified free, press the Right Operation Button to start the Zero Calibration.
- 5 Wait for device to complete Zero Calibration. If passed, the LCD displays APPLY GAS. See [Figure 26](#).

Figure 26 Zero Calibration Display - Passed

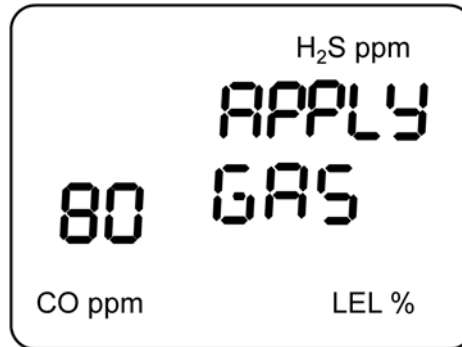

- 6 Wait for device to complete Zero calibration. If failed, the LCD displays FAILED and the appropriate failing sensor(s). See [Figure 27](#).

Figure 27 Zero Calibration Display - Failed



- 7 If Span calibration is desired, continue to See [“Span Calibration” on page 40](#).
- 8 If Span Calibration is not desired, either press the Left Operation Button to exit, or allow 80 second timer to expire.
- 9 When the LCD displays CAL STOPPED, press either Operation Button (Left or Right) to exit calibration mode.

Span Calibration

This section describes how to perform Span Calibration.



Warning: Read, understand and follow the instructions, including labels and MSDS provided by the manufacturer of the calibration gas. Failure to do so may result in injury or death.



For precise K-Factors when performing a Span Calibration of a combustible sensor. See [“Sensor K-Factors” on page 64](#).

Equipment required:

- Calibration gas – Verify concentration level matches detection set points of monitor and expiration date of cylinder has not passed.
- Tygon tubing – 2 feet of 3/16" ID
- Regulator – Set to provide flow at 0.5LPM
- Calibration Adapter – Included with the device



Caution: Gas must be applied at a flow rate of 0.5LPM to perform Span Calibration. Failure to apply gas at the proper flow rate results in failed or inaccurate calibration.



The device can be Span Calibrated using either individual calibration gas cylinders that contain one specific target gas for the sensor being calibrated or a gas mixture cylinder that contains a mixture of each of the target gases required to calibrate each of the sensors the device is presently configured to detect. If using individual gas cylinders to Span Calibrate, the Span Calibration procedure must be completed for each sensor.



The device has an automatic 80 second timer that is enabled when APPLY GAS screen is displayed. If you are unable to apply gas to the sensors within the 80 seconds, CAL STOPPED displays. Pressing the right or left operational button exits calibration mode and the procedure must be repeated.

- 1 Verify the concentration level of the target gas in the cylinder matches the settings of the device as set using the SGM software. See “[Configuring the Scott Gas Monitor Software](#)” on page 23. If needed.
- 2 Attach the Regulator to the gas cylinder and verify cylinder pressure.
- 3 Connect Tygon tubing to both the Regulator and calibration adapter.
- 4 With the device powered on, and if not already accomplished, press and hold the Right Operation Button until the Zero Calibration completes and APPLY GAS or the optional password entry screen displays on the LCD.



If optional password screen is displayed, perform [step 5](#). If not, proceed to [step 6](#).

- 5 If needed, enter the 4-digit password using the Left Operation Button to scroll through the numeric characters and the Right Operation Button to accept the entry and move to the next character.



CAL STOPPED displays if longer than 30 seconds has passed between character entries. Press either the left or right operation button to exit calibration mode and restart procedure.

- 6 Attach the Calibration Adapter to the device and apply gas from the Regulator. See [Figure 28](#).

Figure 28 Span Calibration - Calibration Adapter Attached

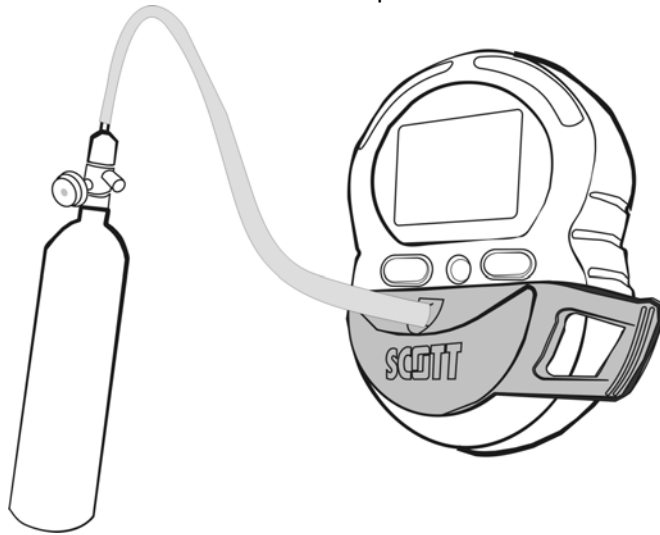

- 7 For single gas cylinders, wait for the display to read CAL PASSED then APPLY GAS. Attach Tygon tubing to next cylinder and apply gas from the Regulator. When final gas has been applied and passed calibration, REMOVE GAS displays. Turn off gas cylinder and remove Calibration Adapter. The device automatically returns to gas monitoring mode. See [Figure 29](#).
- 8 For gas mixture cylinders, wait for the display to read CAL PASSED then REMOVE GAS. Turn off gas cylinder and remove Calibration Adapter. The device automatically returns to gas monitoring mode. See [Figure 29](#).



If you power down the device while the LCD displays CAL PASSED and remove gas the new calibration values are not saved. Ensure you wait until the LCD returns to the gas monitoring mode.

Figure 29 Span Calibration - LCD Display Sequence

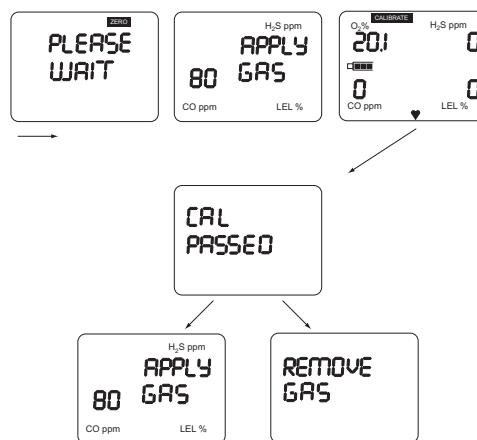

Bump Testing This section describes how to perform Bump Test.

Equipment required:

- Calibration gas – Verify concentration level exceeds set points of monitor and expiration date of cylinder has not passed.
 - Tygon tubing – 2 feet of 3/16" ID
 - Regulator – Set to provide flow at 0.5LPM
 - Calibration Adapter – Included with the device
- 1 Verify the concentration level of the target gas in the cylinder exceeds alarm settings of the Protégé as set using the SGM software. See “[Configuring the Scott Gas Monitor Software](#)” on page 23. If needed.
 - 2 Attach the Regulator to the gas cylinder and verify cylinder pressure.
 - 3 Connect Tygon tubing to both the Regulator and Calibration Adapter.
 - 4 If installed, remove optional pump from device and restart the device.
 - 5 Attach Calibration Adapter to device and apply gas. See [Figure 30](#).

Figure 30 Bump Test - Calibration Adapter Attached

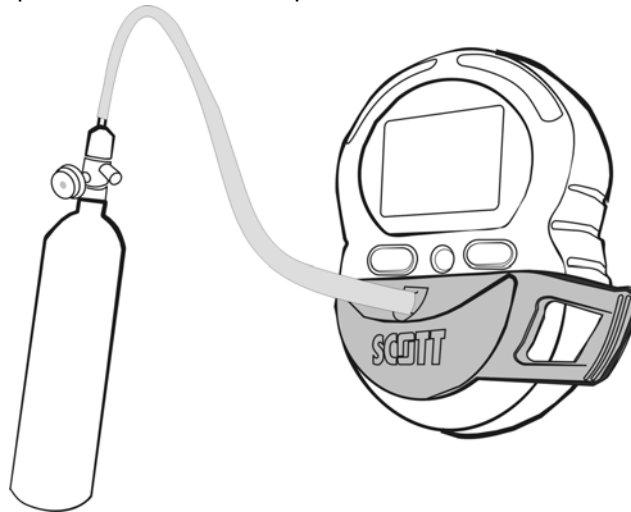

- 6 Verify device responds to target gas and activates the visual, audible, and vibrating alarms.
- 7 Verify readings on the LCD within +/-20% of actual target gas concentration.
- 8 Turn off gas cylinder and remove Calibration Adapter.



Warning: If the device fails to activate all alarms in a timely manner, the device must be serviced prior to usage. If the device fails to read target gas concentration within +/-20%, perform a Span Calibration. Failure to do so could lead to death or injury.

Maintaining the Device

This section covers maintenance of the device. [Table 12](#) details the recommended maintenance item for the device.

Table 12 Recommended Maintenance Matrix

ITEM	ACTIVITY	FREQUENCY	DETAILS
Sensor	Replace	Periodic	See “ Replacing the Sensor ” on page 44.
Pump	Clean	Periodic	See “ Cleaning the Pump ” on page 46.



The device comes installed with a rechargeable lithium-ion battery that must be replaced at the factory if needed. Do not attempt to replace the device’s battery. Contact Scott Safety if needed. See “[Assistance](#)” on page 68.

Replacing the Sensor

This section provides information about the sensors and how to replace them.

The device ships with one of the following sensor configurations:

- A single device installed with an LEL sensor.
- A 2 gas device installed with an O₂ sensor and an LEL sensor.
- A 3 gas device installed with an O₂ sensor, LEL sensor and either a CO or H₂S sensor.
- A 4 gas device installed with an O₂ sensor, LEL sensor, and a Dual Tox H₂S/CO sensor.

Sensors may be replaced with like sensors or Dummy Plug with another Dummy Plug. Dummy Plugs and sensors are not interchangeable.

Using a Dummy Plug, the device can be configured with an O₂ sensor and LEL sensor, or just a LEL sensor.

Required Equipment:

- Replacement Sensor or Dummy Plug
- T8 Torx® Driver

- 1 Set or verify the device is turned off.
- 2 Unscrew and remove the seven (7) Torx head screws from the back of the device. See [Figure 31](#).

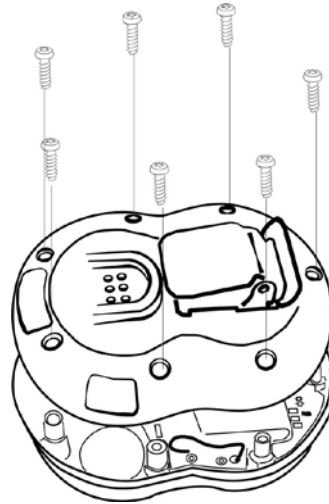
Figure 31 Removing Device Cover

- 3 Lift and firmly pull housing cover apart. Do not pull apart at an angle or by twisting.
- 4 Rotate the sensor PC board over to expose the three (3) sensors. See [Figure 32](#).
- 5 Unplug desired sensor and replace with new sensor.

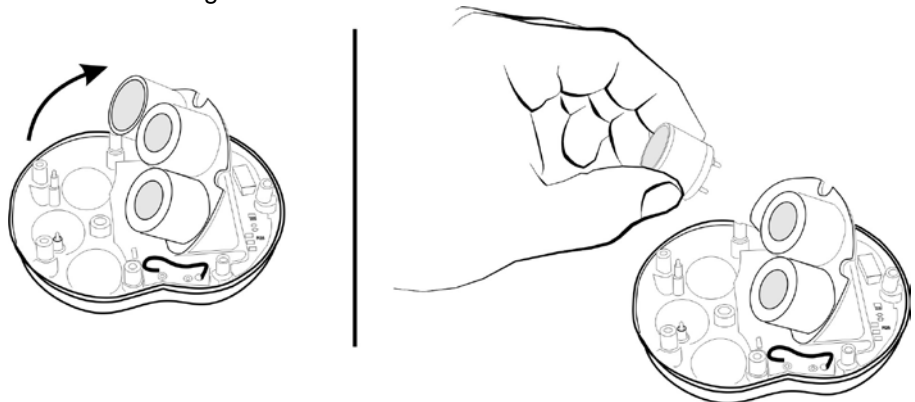
Figure 32 Removing Sensor

Each sensor type has a unique position and pin locations to prevent sensors being installed in wrong locations.

- 6 Rotate PC board back to its original position aligning the two (2) pins to their receptacle socket. See [Figure 33](#).

Figure 33 Sensor Pin Alignment

- 7 Replace back cover and install the seven (7) Torx screws. Hand-tighten the screws taking care not to over torque as this can cause damage to the device housing.
- 8 Use the SGM software to set or verify settings for the newly installed sensor. See See “[Configuring the Scott Gas Monitor Software](#)” on page 23.
- 9 Perform Zero and Span Calibrations of the device in accordance with calibration procedures. See “[Zero Calibration](#)” on page 39. See “[Span Calibration](#)” on page 40.

Cleaning the Pump

This section describes how to clean the pump.



Warning: *If device does not operate in the manner described, do not use. Tag it out of service. Failure to ensure it is properly operating may result in serious injury or death.*

Required Equipment:

- 10ml Syringe
- Tygon Tubing
- T8 Torx head screw driver
- Isopropyl Alcohol (IPA)
- Can of compressed air

- Canned compressed air (Electronic Grade)

1 Using the T8 Torx head driver, remove the four (4) Torx head screws located on the back of the pump assembly. See [Figure 34](#).

Figure 34 Removing Pump Screws



2 Lift the back cover off the pump enclosure and remove the pump retaining plate. This allows access to the pump. Gently lift the pump out of the pump enclosure. See [Figure 35](#).

Figure 35 Disassembly of Pump

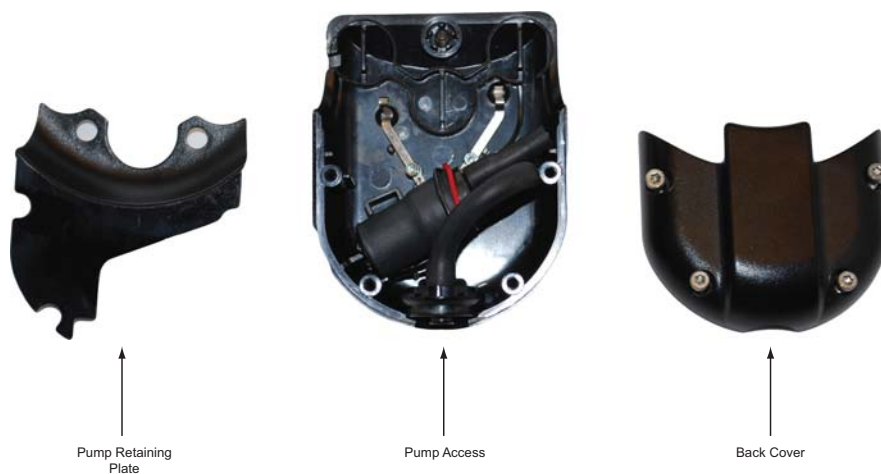

3 Carefully remove the tubing from the pump ports.



Caution: Use only the minimum force necessary to remove hoses from ports. Pump ports break easily if excessive force is used.



To easily identify hoses for reinstallation, attach locally generated labels to the hoses. The short hose is the **OUTLET** and the long hose is the **INLET**. See [Figure 36](#).

Figure 36 Pump Ports and Hoses



- 4 Connect a piece of the Tygon tubing to the syringe and draw about 3ml of isopropyl alcohol into the tubing and syringe. See [Figure 37](#).

Figure 37 Setup Syringe



- 5 Connect the syringe and Tygon tubing to the INLET port.
- 6 Connect another piece of Tygon tubing to the OUTLET port and run the Tygon tubing to a catch basin such as a small cup or trash can.
- 7 Slowly inject the isopropyl alcohol through the pump by pressing the plunger on the syringe.
- 8 Once the isopropyl alcohol is inside the pump and tubing, pump the syringe plunger in and out 5-7 times. Then depress the syringe plunger completely to eject the isopropyl alcohol from the pump.
- 9 Carefully disconnect the Tygon tubing from the pump ports.

- 10** Use the can of compressed air to blow the excess isopropyl alcohol from the pump. The thin tube that comes with the can of air may be helpful in directing the air stream into the pump ports. The pump should make an audible whir as it spins.
- 11** Re-attach the pump tubing to the INLET (long) and OUTLET (short) ports.
- 12** Place the pump assembly into the enclosure with the ports positioned over top of one another. The OUTLET port should be on top and the INLET port should be on the bottom. Verify the wires are routed on top of the assembly. See [Figure 38](#).

Figure 38 Routing the Pump Wires

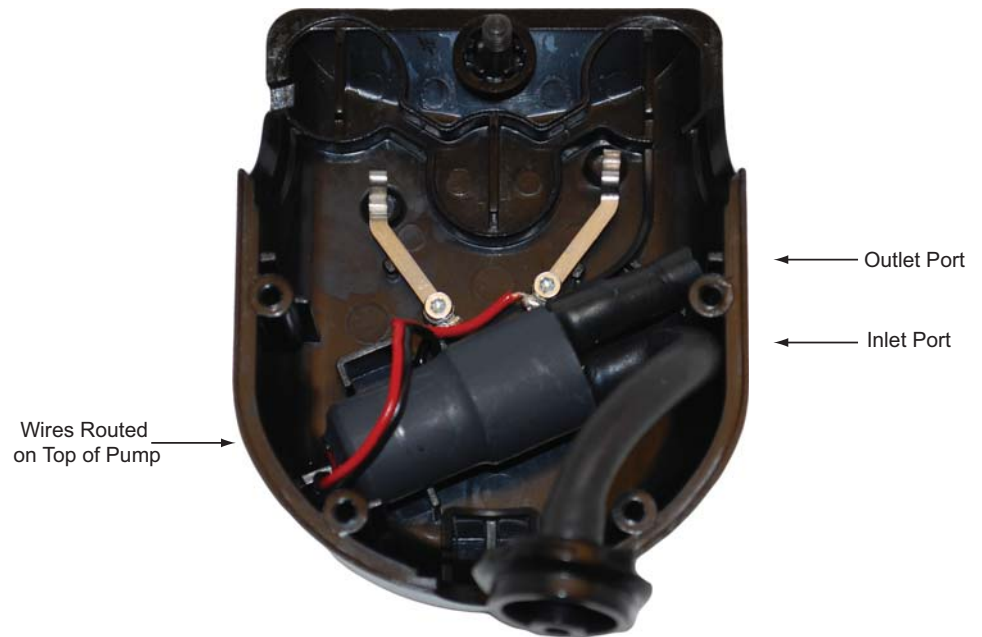

- 13** Insert the pump retaining plate.
- 14** Place the pump inlet barb into the pump enclosure groove. See [Figure 39](#).

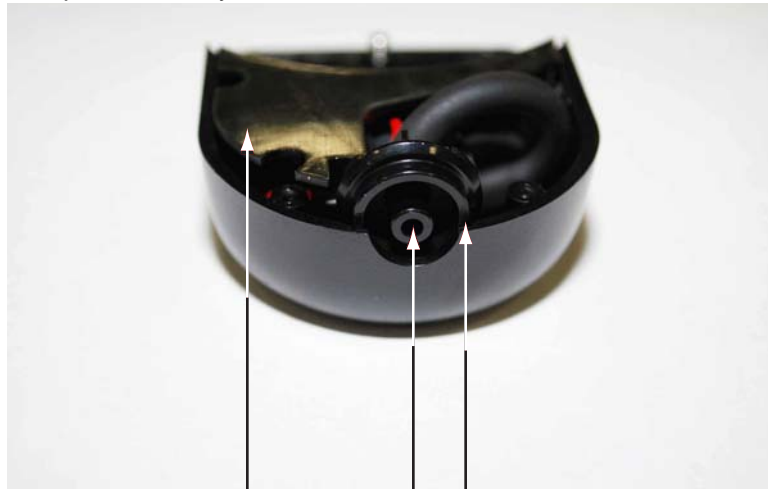
Figure 39 Pump Reassembly

Pump
Retaining
Plate

Pump Inlet
Barb

Rounded
Groove

15 Gently place the back cover onto the pump enclosure and install the four (4) Torx head screws. Follow an X pattern to ensure that the enclosure halves are seated together evenly.



Caution: Do not over tighten the screws. Over tightening the screws strips the holes in the enclosure.

16 Install pump onto an operational device and verify proper flow rate is achieved.

Troubleshooting the Device

Refer to [Table 13](#) for troubleshooting assistance.

Table 13 Troubleshooting Matrix

CAUSE	SOLUTION
Low Flow Alarm	<ul style="list-style-type: none"> • Check for obstructions, kinks in the hose, or other blockage • Verify no moisture has entered the hose or pump • Unscrew probe assembly and replace filter(s) in probe • Clean pump. See “Cleaning the Pump” on page 46.
Unexpected chattering noise coming from pump during operation	<ul style="list-style-type: none"> • Verify no moisture has entered the hose or pump • Clean pump. See “Cleaning the Pump” on page 46. • Replace pump
Pump does not run when activated	<ul style="list-style-type: none"> • Verify no other alarms are active. Active alarms may inhibit pump from powering on • Replace pump
The pump fails the start-up flow test	<ul style="list-style-type: none"> • Clean pump. See “Cleaning the Pump” on page 46.
The sample draw reading indicates less than 300cc/min (0.3LPM)	<ul style="list-style-type: none"> • Clean pump. See “Cleaning the Pump” on page 46.
Device within 1 to 2’ of a high-powered portable radio (reading fluctuates, alarms & vibrates)	<ul style="list-style-type: none"> • Perform Bump Test prior to putting device back into service. See “Bump Testing” on page 43.

Appendix A



Appendix Overview

This appendix covers the following topic:

- [Specifications](#)

Specifications

Table 14 lists the device's specifications. Table 15, Table 16, Table 17 and Table 18 lists the applicable sensor specifications.

Table 14 Device Specifications

DEVICE SPECIFICATIONS		
Nominal Voltage	4.2VDC	
Calibration	Automatic calibration and zero	
Battery	Lithium ion rechargeable; ~5Hrs. charge time	
Battery Life	18Hrs no pump; 12Hrs with pump	
Alarms	Audible	90dB @ 6"
	Visual	Wide-angle dual red alarm bars
	Tactile	
Data Log	Up to 7000 events	
Housing	ABS/rubber over mold	
Dimensions	3.26Hx2.76Wx1.16"D (8.28Hx7.01Wx2.95cmD)	
Weight	7.5oz (233.28g)	
Operating Temperature	-4.0 to +122°F (-20 to +50°C)	
Operating Humidity	0 to 90% RH, Non-Condensing	
EMI/RFI	EMC 89/336/EEC compliant	

Table 15 Hydrogen Sulfide Sensor Specifications

HYDROGEN SULFIDE SENSOR SPECIFICATIONS		
Range	0 to 500ppm	
Response Time	T90 <30sec	
Operating Temp.	-4.0 to +122°F (-20 to +50°C)	
Humidity	15 to 90% RH, Non-Condensing	
Storage Temp.	+32 to +68°F (0 to 20°C)	
Sensor Cross Sensitivity	Carbon Monoxide at 300ppm	<2ppm
	Sulfur Dioxide, 5ppm	~1ppm
	Nitric Oxide, 25ppm	<1ppm
	Hydrogen, 10,000ppm	<10ppm
	Nitrogen Dioxide, 5ppm	~ppm

Table 16 Carbon Monoxide Sensor Specifications

CARBON MONOXIDE SENSOR SPECIFICATIONS		
Range	0 to 999pm	
Response Time	T90 <250Sec	
Operating Temp.	-4.0 to +122°F (-20 to +50°C)	
Humidity	15 to 90% RH, Non-Condensing	
Storage Temp.	+32 to +68°F (0 to 20°C)	
Sensor Cross Sensitivity	Filtered against H ₂ S, 15ppm	<0.5ppm
	Filtered against SO ₂ , 5ppm	~ 0ppm
	Nitric Oxide, 35ppm	<3ppm
	Nitrogen Dioxide, 5ppm	-1ppm
	Chlorine, 1ppm	~0ppm
	Hydrogen, 100ppm	<40ppm
	Ethylene, 100ppm	<50ppm
	Ethanol, 200ppm	~ 0ppm

Table 17 Oxygen Sensor Specifications

OXYGEN SENSOR SPECIFICATIONS	
Range	0.0 to 25.0%
Response Time	T95=15Sec
Operating Temp.	-4.0 to +122°F (-20 to +50°C)
Humidity	0 to 90% RH, Non-Condensing
Storage Temp.	+32 to +68°F (0 to 20°C)

Table 18 Combustible Sensor Specifications

COMBUSTIBLE SENSOR SPECIFICATIONS	
Range	0 to 80%LEL; 0 to 5.0% v/v Gas
Response Time	T50=10Sec; T90=30Sec
Operating Temp.	-40 to +392°F (-40 to +200°C)
Humidity	0 to 90% RH, Non-Condensing
Storage Temp.	+32 to +68°F (0 to 20°C)

SCOTT QUICK REFERENCE S A F E T Y

Appendix Overview

This appendix covers the following topics:

- [Quick Setup](#)
- [Alerts & Messages](#)
- [Powering the Device](#)
- [Daily Bump Test](#)
- [Daily Zero Calibration](#)
- [Span Gas Calibration](#)
- [Optional Pump](#)

Quick Setup

This section provides a brief amount of information for a quick setup.

- 1 Connect cables and Shoe Pad to Protégé. Fully charge the Protégé prior to first use.
- 2 Install Scott Gas Monitor software (SGM) on PC.
- 3 Use software to customize alarm settings and write data to monitor.
- 4 Remove Shoe Pad and Power On the Protege. Perform a ZERO Cal, SPAN Cal, and daily BUMP test. See [Figure 40](#).

Figure 40 Connecting the Device to a PC

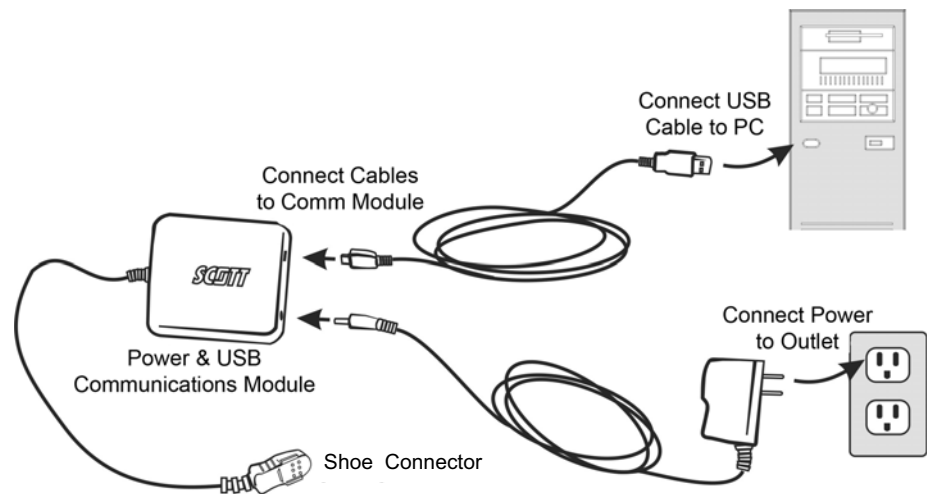

Alerts & Messages

This section provides a brief amount of information on alerts and messages.

- Alarms – The device alerts you of alarm conditions through flashing LEDs, an audible alarm, and vibration. The specific sensor will flash with a HIGH or LOW indication on the LCD. Alarm intensity increases from a LOW to a HIGH condition.
- LowBattery – The battery icon flashes and activate the alarms.
- Over-Range Conditions – Device’s sensor(s) have been exposed to +++ very high gas concentration exceeding sensor range.
- Pump – Displays when pump is connected to device. Icon flashes along with activating alarms when a low flow situation occurs.
- Sensor Failures – FAILED indicates along with the sensor type for each sensor that fails to ZERO or SPAN calibrate.
- Calibration Expired – Indicates device calibration is overdue. A SPAN calibration must be performed prior to using the device.
- Heart Beat – Blinking indicates device is actively monitoring properly maintained sensors.

Powering the Device

This section provides a brief amount of information on powering the device up and down.

- Power Up – Hold down either the Left or Right Operation Button until the LCD displays RELEASE.
- Power Down – Push both Left and Right Operation Buttons until timer counts down and LCD shuts down.

See [Figure 41](#).

Figure 41 Left and Right Operation Buttons

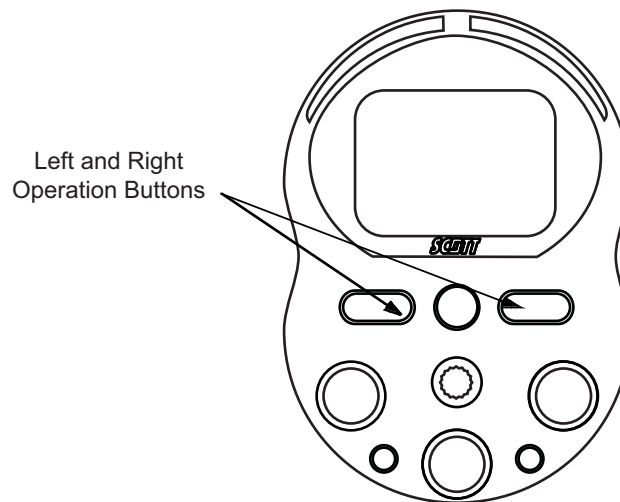

Daily Bump Test

This section provides a brief amount of information on daily bump testing.

If installed, remove optional pump. Attach the Calibration Adapter and thread Regulator to the calibration gas cylinder. Connect tubing. Apply gas. Device should quickly respond to the target gases and begin alarming. Verify proper operation of alarms. If device fails to respond (or is slow) or readings are not within 10% of the actual gas concentration, SPAN Calibration is required. See [Figure 42](#).



Caution: Do not operate the device with the Calibration Adapter attached.

Figure 42 Span Calibration - Calibration Adapter Attached

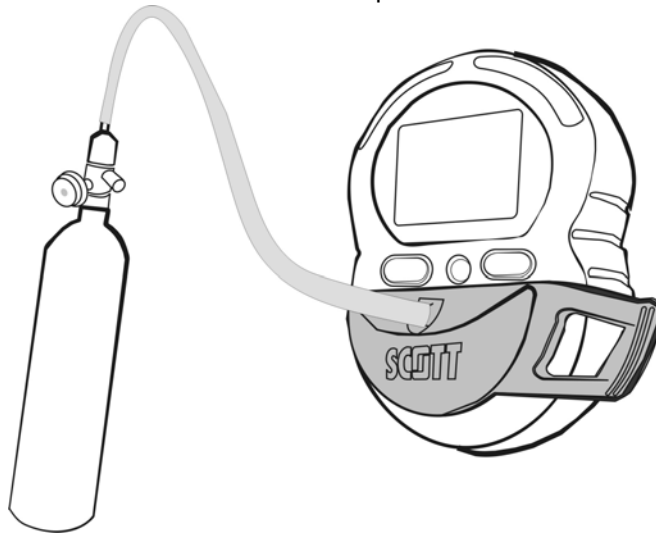

Daily Zero Calibration

This section provides a brief amount of information on daily zero calibration.

In clean atmosphere, press and hold the Right Operation button. Release when display reads PLEASE WAIT. Device automatically perform ZERO calibration. Press Left Operation button when display reads APPLY GAS to exit. See [Figure 41](#).

Span Gas Calibration

This section provides a brief amount of information on span gas calibration.

The device's calibration gas concentration as set in the Scott Gas Monitor (SGM) software setting must match actual gas concentration used. Perform ZERO calibration procedure connecting the Calibration Adapter with hose and regulator when APPLY GAS displays. Once each sensor is calibrated, the device displays CAL PASSED then REMOVE GAS. Remove Calibration Adapter and **wait** for the device's main display to return before turning off the device.

Optional Pump

This section provides a brief amount of information on the Optional Pump.

Connect pump. See [Figure 43](#). Power on the device or push the Left Operation button to activate the pump. When BLOCK PUMP displays, place a finger over the probe until CLEAR PUMP displays. To disconnect pump, press and hold the Left Operation button until PEAK EXPOSURES displays. Remove pump.

Figure 43 Pump Installation

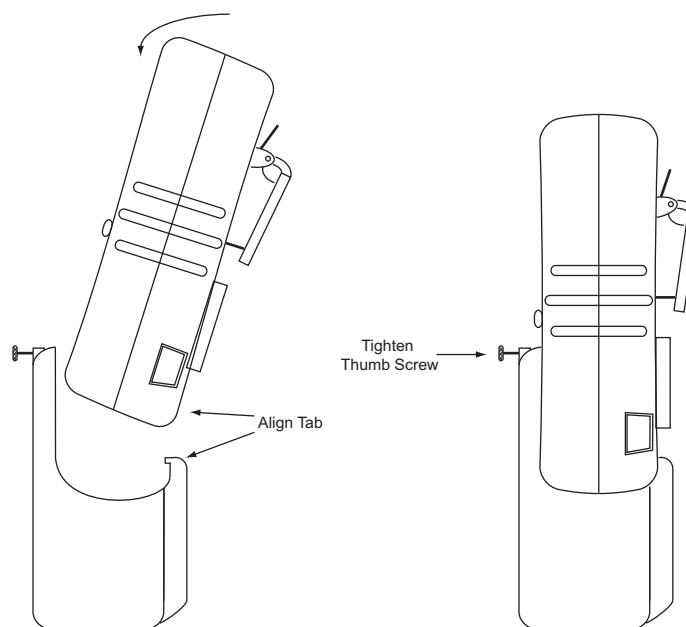

SCOTT SENSOR INFORMATION S A F E T Y

Appendix Overview

This appendix covers the following topics:

- [Sensor K-Factors](#)
- [Gas Interferences](#)

Sensor K-Factors

Table 19 provides the K-Factors referenced to methane calibration. The factors are the typical ratios of the response to the listed gases relative to the response to methane. The values are typical, but will vary from sensor to sensor and over the lifetime of a given sensor. When a gas other than the calibration gas is detected, divide the reading by the corresponding factor to estimate the actual gas concentration. For example, propane may be detected by the device calibrated with methane. If the reading is 32% LEL: 32% LEL Methane indicated/0.65 = 49% LEL of propane, estimated. Generally, if there is a potential for methane in the operating environment, the instrument should be calibrated with methane. If there also is a potential for other gases in the operating environment, the LEL alarm level should be adjusted according to the lowest K-Factor of the expected gases. For example, if either methane or propane may be present, and the desired alarm is 25% LEL, calibrate the instrument with methane and set the alarm level at (25% x 0.65 = 16% LEL). For best accuracy, calibrate the device with a gas similar to the monitored target gas.

Table 19 Combustible Sensor K-Factors

KNOWN GAS PRESENT	K-FACTORS
n-Butane	0.6
Methanol	1.04
Ethane	0.8
Hydrogen	1.1
Methane	1
Propane	0.65
n-Pentane	0.5
n-Hexane	0.45
n-Octane	0.4
Ethanol	0.8
Isopropanol	0.69
Acetone	0.7
Ammonia	1.3
Toluene	0.35
Gasoline	0.6
Isobutanol	0.53
Xylene	0.49
Styrene	0.46

Gas Interferences

There are known gas interferences to a limited number of chemical compounds. Scott Safety attempts to identify possible gas interferences to which gas sensors may be exposed; however, not all chemical compounds that presently exist have been tested. Table 20 provides known toxic gas interferences.



Table 20 does not show, nor should it be implied, that no additional interferences may occur. These selectivity ratios are used as guides only. They are not to be used as calibration factors. The gas species' actual cross-sensitivities may vary from the values shown.

Table 20 Gas Interferences

		SENSOR TYPES (ALL VALUES IN PPM)			
		Dual-Tox Sensor			
		CO	H ₂ S	CO	H ₂ S
Interference Gas	CO	1	< 0.02	1	< 0.02
	H ₂ S	< 0.04	1	< 0.25	1
	SO ₂	< 0.2	< 0.2	< 0.25	< 0.1
	NO ₂	< 0.02	~ -0.2	-0.25 to 0	< -0.3
	NO	< 0.003	< 0.03	< 0.5	< 0.02
	NH ₃			< 0.001	< 0.001
	H ₂	~ 0.2	0.003	< 0.6	< 0.005
	CL ₂	0	0	< 0.001	< -0.25

Key: < Less than; ~ Approximate.
 For each sensor type, the table shows how 1ppm of an Interference Gas appears on that specific sensor type. For example, 1ppm CO appears as less than 0.02ppm on a H₂S sensor.

Appendix D



Appendix Overview

This appendix covers the following topics:

- [Assistance](#)
- [Parts List](#)
- [Warranty Statement](#)
- [Product Information](#)

Assistance

Congratulations on your purchase of a Scott Safety product. It is designed to provide you with years of reliable trouble-free service.

- If you have technical questions or need support.
- If you need to return a product.

Contact us using the options provided:

- By E-mail: techsupport.scotths.us@tycoint.com
- By Telephone: 1- 800-247-7257



When returning a product, contact Technical Support to obtain a Return Material Authorization (RMA) number prior to shipping for service repairs using the contact options.

Parts List

Table 21 provides a parts list.

Table 21 Applicable Parts List











CATEGORY	ITEM	DESCRIPTION	PART NUMBER
Accessories		Device Top Case Replacement Kit (Includes case top assembly, sensor membranes, horn membranes)	096-3249
		LCD Replacement Assembly	096-3247
		Optional Automatic Draw Pump	096-3259
		Portable Gas Detectors CD	096-3366
		T-8 Torx Driver	073-0324
		14" Probe Assembly	093-0148
		Calibration Adapter	074-0547
		Optional Automatic Draw Pump Kit (Includes pump, 10' of tubing, and probe)	096-3271
		Protege Multi-Charger	096-3283
		Protege Masterdock Docking Station	093-0526

Table 21 Applicable Parts List (continued)







CATEGORY	ITEM	DESCRIPTION	PART NUMBER
Accessories		Power & USB Communication Module	096-3257
		AC Power Adapter	028-0045
		International plug adapters for AC Power Adapter (028-0045)	International: 028-0046
		USB Cable	077-1353
		10ML Syringe	077-0422
		Carry Case	096-3273
		Device Case Replacement Kit (Includes case top assembly, case bottom assembly, sensor membranes, horn membranes, M2.5x10 delt pt screw, device serial number label and device approvals label)	096-3248
		Dummy Plug	074-0558

Table 21 Applicable Parts List (continued)

CATEGORY	ITEM	DESCRIPTION	PART NUMBER
Sensors		Combustible Sensor	093-0231
		Combustible Sensor - CSA	093-0524
		Oxygen Sensor	093-0232
		CO/H ₂ S Sensor	093-0230
		CO Sensor	093-0470
		H ₂ S Sensor	093-0471

Table 21 Applicable Parts List (continued)

CATEGORY	ITEM	DESCRIPTION	PART NUMBER
Calibration Kits (The specific Calibration Kit depends on the sensors in your device)		Includes regulator, 24" tubing, and calibration gas (CO, H ₂ S, Methane, O ₂ with balance of N ₂)	096-2506-16
		Includes regulator, 24" tubing, and calibration gas (CO, Methane, O ₂ with balance of N ₂)	096-2506-18
		Includes regulator, 24" tubing, and calibration gas (H ₂ S, Methane, O ₂ with balance of N ₂)	096-2506-20
		Includes regulator, 24" tubing, and calibration gas (Methane, with balance of air)	096-3272
		Includes regulator, 24" tubing, and calibration gas (CO, H ₂ S, Propane, O ₂ with balance of N ₂)	096-3392
		Includes regulator, 24" tubing, and calibration gas (CO, H ₂ S, Pentane, O ₂ with balance of N ₂)	096-3393
Note: For calibration equipment, contact your Scott sales representative.			

Warranty Statement

Scott Safety (SCOTT), a division of Scott Technologies Inc. warrants the Protege PORTABLE GAS DETECTION PRODUCTS (THE PRODUCTS) to be free from defects in workmanship and materials for a period of two (2) years from the date of original manufacture by SCOTT.

This warranty applies to all components of THE PRODUCTS supplied at the time of original sale of THE PRODUCTS, EXCEPT pump and consumable filters. SCOTT warrants pump supplied with THE PRODUCTS to be free from defects in workmanship and materials for one (1) year from the date of original manufacture by SCOTT.

SCOTT's obligation under this warranty is limited to replacing or repairing (at SCOTT's option) THE PRODUCTS or components shown to be defective in either workmanship or materials.

Only personnel of SCOTT or, when directed by SCOTT, authorized SCOTT agents are permitted to perform warranty obligations. This warranty does not apply to defects or damage caused by any repairs of or alterations to THE PRODUCTS made by owner or any third party unless expressly permitted by SCOTT product manuals or by written authorization from SCOTT.

To obtain performance under this warranty, and as a condition precedent to any duty of SCOTT, the purchaser must return such products to SCOTT, a SCOTT authorized distributor or a SCOTT authorized service center. See [“Assistance” on page 68](#).

This warranty does not apply to any malfunction of or damage to THE PRODUCTS resulting from accident, alteration, misuse, or abuse.

THIS WARRANTY IS MADE IN LIEU OF ALL OTHER WARRANTIES, EXPRESSED OR IMPLIED INCLUDING, BUT NOT LIMITED TO, ANY IMPLIED WARRANTY OF MERCHANTABILITY OR FITNESS FOR A PARTICULAR PURPOSE. IN ADDITION, SCOTT EXPRESSLY DISCLAIMS ANY LIABILITY FOR SPECIAL, INCIDENTAL OR CONSEQUENTIAL DAMAGES IN ANY WAY CONNECTED WITH THE SALE OR USE OF SCOTT PRODUCTS, AND NO OTHER FIRM OR PERSON IS AUTHORIZED TO ASSUME ANY SUCH LIABILITY.

Product Information

For general information on our products, refer to our Web site:

- <http://www.scottsafety.com/>

A

Approvals and Certifications [xvi](#)

B

Battery

Charging [7](#)

Battery Use and Care

Warnings and Cautions [xxiii](#)

Bump Test

Calibration Adapter Attached [43](#)

Buttons

Power Up [33](#)

C

Calibration Adapter Attached

Bump Test [43](#)

Span Calibration [42](#)

Certifications and Approvals [xvi](#)

Charging

Battery [7](#)

Cleaning

Multi-Charger [10](#)

Connecting

Device to a PC [23](#)

D

Device

Major Parts [3](#)

Device Cover

Removing [45](#)

Device Icon

SGM [22](#)

Device to a PC

Connecting [23](#)

Device Use and Care

Warnings and Cautions [xx](#)

Disassembly

Pump [47](#)

Display

Failed

Zero Calibration Display [40](#)

E

Email

Technical Support [68](#)

G

General Safety Information [xix](#)

Guide Conventions [xiii](#)

Guide Overview [xi](#)

H

Home Screen

Scott Gas Monitor (SGM) Software [24](#)

http

//www.scottsafety.com/ [74](#)

I

In Progress

Zero Calibration Display [39](#)

Indicators

LCD [30](#)

Installation

Pump [18](#)

Installation Complete

JAVA JRE Software [17](#)

Installation Completed

Scott Gas Monitor Software [15](#)

Installation Destination Folder

Scott Gas Monitor Software [14](#)

Installation End User License

Scott Gas Monitor Software [13](#)

Installation Google

JAVA JRE Software [16](#)

Installation Setup

Scott Gas Monitor Software [13](#)

Installation Welcome

JVA JRE Software [16](#)

J

- JAVA JRE Software
 - Installation Complete 17
 - Installation Google 16
- JVA JRE Software
 - Installation Welcome 16

L

- LCD
 - Indicators 30
- LCD Display Sequence
 - Span Calibration 42

M

- Major Parts
 - Device 3
- Mounting
 - Multi-Charger
 - 8, 8, 9, 10
- Multi-Charger
 - Cleaning 10
 - Mounting 8
 - Use 9

P

- Passed
 - Zero Calibration Display 40
- Pin Alignment
 - Sensor 46
- Ports and Hoses
 - Pump 48
- Power Up
 - Buttons 33
- Pump
 - Disassembly 47
 - Installation 18
 - Ports and Hoses 48
 - Reassembly 50
- Pump Displays
 - Start Up 19
- Pump Screws
 - Removing 47
- Pump Wires
 - Routing 49

R

- Ready to Install
 - Scott Gas Monitor Software Installation 14
- Reassembly
 - Pump 50
- Related Product Documentation xiv

Removing

- Device Cover 45
- Pump Screws 47
- Sensor 45

Revision history, for this guide xv

Routing

- Pump Wires 49

S

- Scott Gas Monitor (SGM) Software
 - Home Screen 24
 - Set Clock Screen 25
 - Settings Screen 24
 - View Log Screen 26
- Scott Gas Monitor Software
 - Installation Completed 15
 - Installation Destination Folder 14
 - Installation End User License 13
 - Installation Ready to Install 14
 - Installation Setup 13
- Sensor
 - Pin Alignment 46
 - Removing 45
- Sensor Use and Care
 - Warnings and Cautions xxii
- Set Clock Screen
 - Scott Gas Monitor (SGM) Software 25
- Settings Screen
 - Scott Gas Monitor (SGM) Software 24
- Setup
 - Syringe 48
- SGM
 - Device Icon
 - 22
- Span Calibration
 - Calibration Adapter Attached 42
 - LCD Display Sequence 42
- Start Up
 - Pump Displays 19
- Syringe
 - Setup 48

T

- Technical Support
 - Email 68
 - Telephone Number 68
 - Web Site 68
- Telephone Number
 - Technical Support 68
- Troubleshooting 51

U

Use

Multi-Charger 9

Using Scott Safety Electronic Documents xii

V

View Log Screen

Scott Gas Monitor (SGM) Software 26

Vista

Windows 12

W

Warnings and Cautions

Battery Use and Care xxiii

Device Use and Care xx

Sensor Use and Care xxii

Web Site

Technical Support 68

Windows

Vista 12

Vista OS 12

Z

Zero Calibration Display

Failed 40

In Progress 39

Passed 40



Monroe Corporate Center

P.O. Box 569

Monroe, NC 28111

Telephone: 800-247-7257

FAX: (704) 291-8330

Web: www.scottsafety.com