



Enviro-Equipment Inc.
10120 Industrial Drive
Pineville NC 28134

Stock#: 694

Status: In stock

Dimensions: 24"x13"x23"

Weight: 171 lbs

Description: Liquid-Ring pump with Baldor Electric motor

Blower:

Model#- A75

Serial#- 18851

Motor:

MFG- Baldor

HP- 5

RPM- 1725

Volts- 230/460

Amps- 13/6.5

3 phase

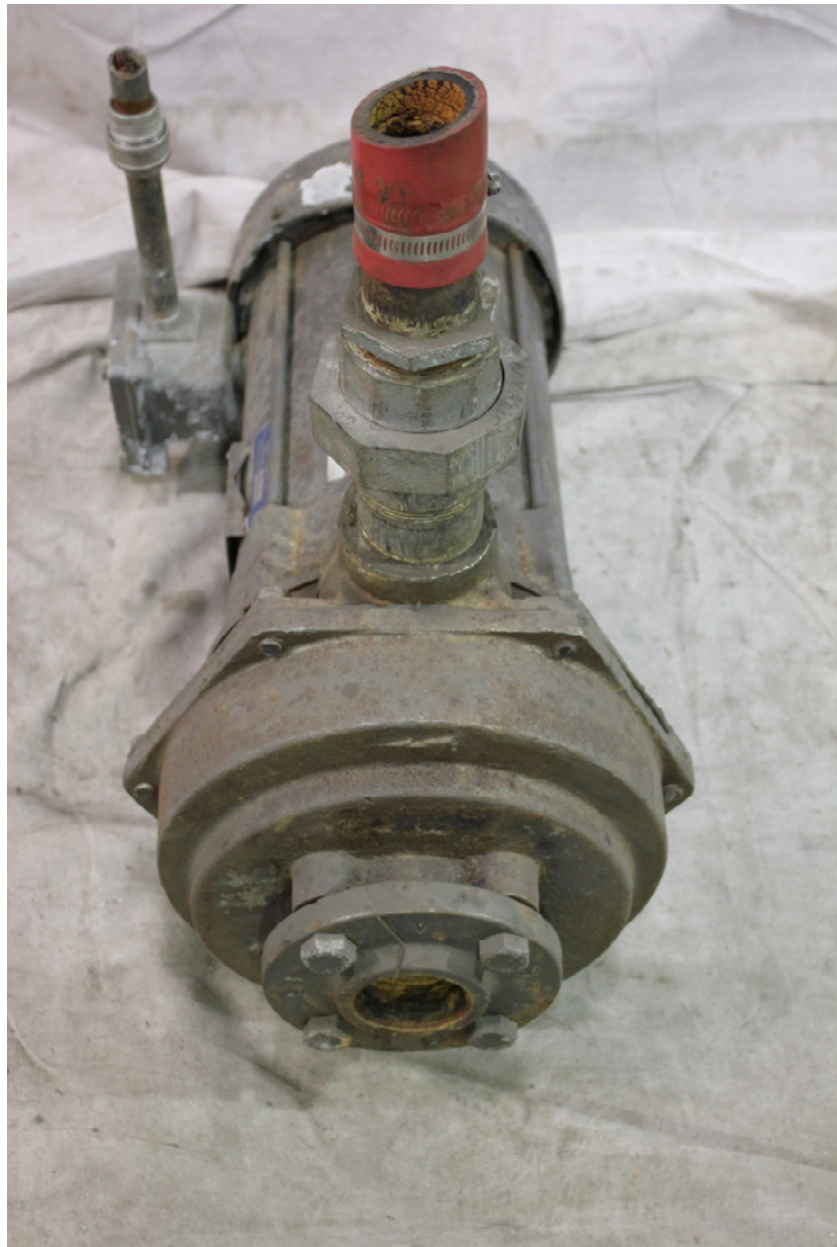

KINNEY® A SERIES

Single-Stage, Liquid Ring Vacuum Pumps

Models: **A75** **A100** **A130**

Features

- No contact between operating components in the casing
- Flat power curve over entire vacuum range prevents motor overload
- Reduced stress on motor shaft and bearings
- Increased water handling capability prevents heat build-up, extends life of mechanical seals
- Compact, close-coupled design eliminates need for interstage manifold or motor alignment
- Shrouded rotor increases pumping efficiency for high vacuum and low water consumption
- Fast delivery on standard materials and local support
- Manufactured in Springfield, Missouri USA

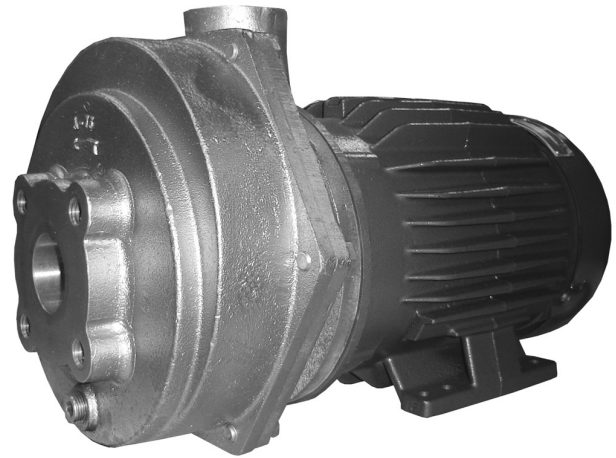

Materials of Construction

Casing, Cover, Rotor, Port Cylinder:

- All Bronze
- Cast Iron, Bronze Fitted
- All Stainless Steel

Mechanical Seals:

- BUNA — Optional
- Viton™ — Cast Iron Bronze Fitted, All Bronze, Stainless Steel
- EPR — Optional
- Kalrez™ — Optional

Drive Options:

- Pedestal Frame
- Close-coupled motor

Stocked Motors:

- TEFC – 3Ø
- TEFC – 1Ø

Optional Motors:

- XP Class I, GpD – 3Ø – Optional
- XP Class I, GpD – 1Ø – Optional

Typical Pumping Speed Curves

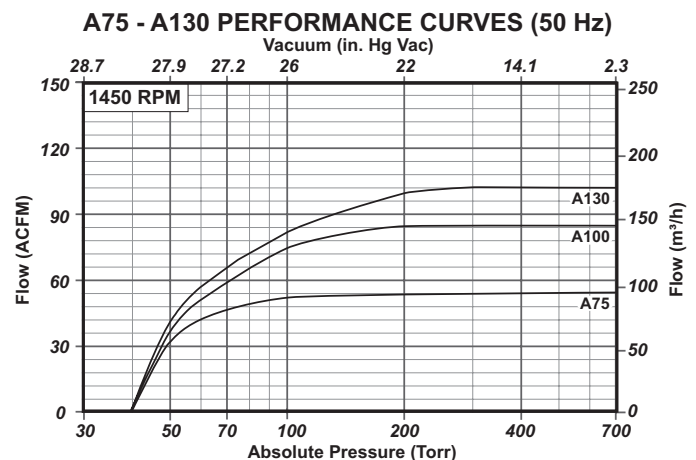
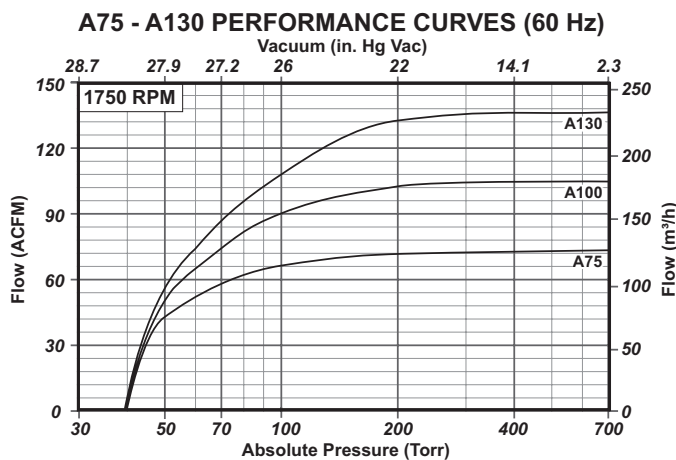

Performance curves are based on dry air at 68°F (20°C), 60°F (15°C) seal water, and 29.92 inches of mercury (760 torr) barometric pressure.

Dimensions:

Values shown are approximate and should not be used for construction.
 Certified drawings are available through your local Tuthill Vacuum & Blower Systems Sales Professional
 All dimensions are shown in inches and *millimeters*.

Models **A75** **A100** **A130**

Close-Coupled Design

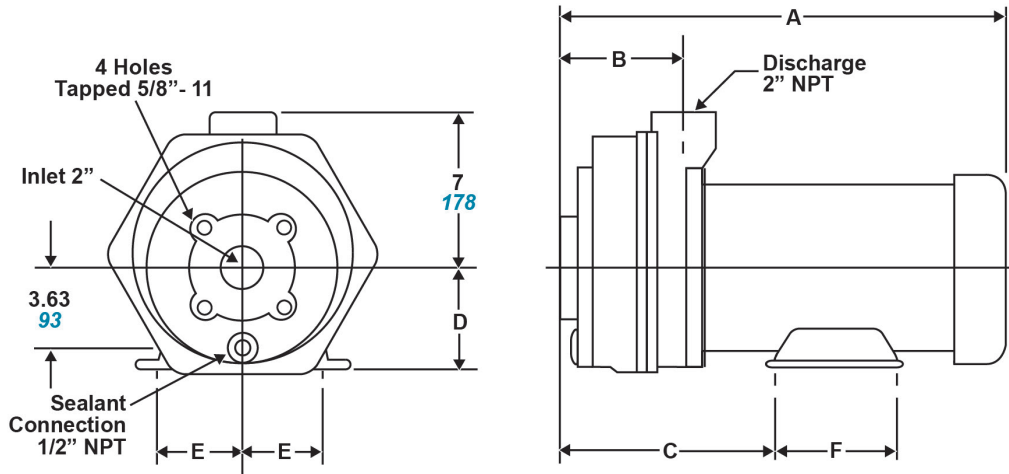

MODEL	FRAME	INLET	inches/mm						MOTOR HP	Weight (lbs./kg)
			A	B	C	D	E	F		
A75	184TCZ	2" Flange	20.2 / 513	5.8 / 147	10 / 254	4.50 / 114	3.75 / 95	5.5 / 140	5	180 / 82
A100	213TCZ	2" Flange	23.1 / 587	7.1 / 180	12.1 / 307	5.25 / 133	4.25 / 108	7.0 / 178	7 1/2	195 / 89
A130	215TCZ	2" Flange	25.3 / 642	8.1 / 206	13.1 / 333	5.25 / 133	4.25 / 108	7.0 / 178	10	250 / 114

Pedestal Mount Design

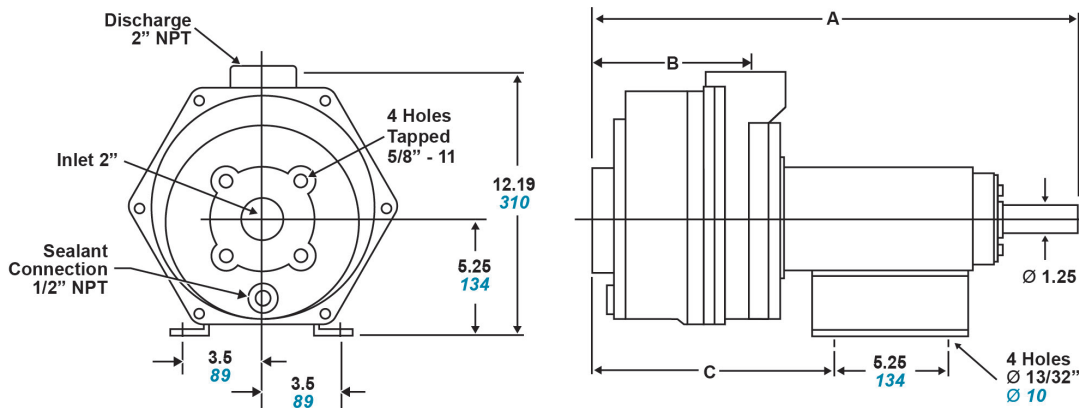

MODEL	INLET	inches/mm			Weight (lbs./kg)
		A	B	C	
A75	2" Flange	20.57 / 369	5.75 / 89	9.44 / 157	125 / 57
A100	2" Flange	21.88 / 377	7.07 / 97	10.75 / 165	130 / 59
A130	2" Flange	22.88 / 396	8.07 / 117	11.75 / 185	145 / 66

Your Local Tuthill Vacuum & Blower Systems Sales Professional:



Tuthill Vacuum & Blower Systems
 4840 West Kearney Street
 Springfield, Missouri USA 65803-8702
 o 417.865.8715 800.825.6937 f 417.865.2950
 tuthillvacuumblower.com

