



Enviro-Equipment Inc.
10120 Industrial Drive
Pineville NC 28134

Serial#: EEI-1277

Date: 9/19/2014

Status: In stock, Tested

Description: Soil Vapor Extraction Pilot Test Skid

- Rotron EN523M5L Blower with 3HP 1PH 230V XP Motor, 84 SCFM Max Flow, 135" WC Max Vacuum
- 0 to 150" WC Magnehelic Pressure and Vacuum Gauges
- ¼" Intake and Exhaust Sample Ports with Ball Valves
- 2" Intake and Exhaust Aluminum Camlock Connections
- XP Start/Stop Station 230V 1PH with Power Cord
- Solberg CSL-848-150HC Vacuum Filter
- Rotron MS300PS Moisture Separator with 2" Camlock Connections, Vacuum Gauge, Vacuum Relief Valve, Manual Drain
- 2"/4"/6" Well Head Adapter with 2" Camlock Connections, 2" Dilution Ball Valve 3/8" Ports for Anemometer Readings Before and After Dilution Valve for Calculating Flow, Vacuum Gauge.





Enviro-Equipment Inc.
10120 Industrial Drive
Pineville NC 28134

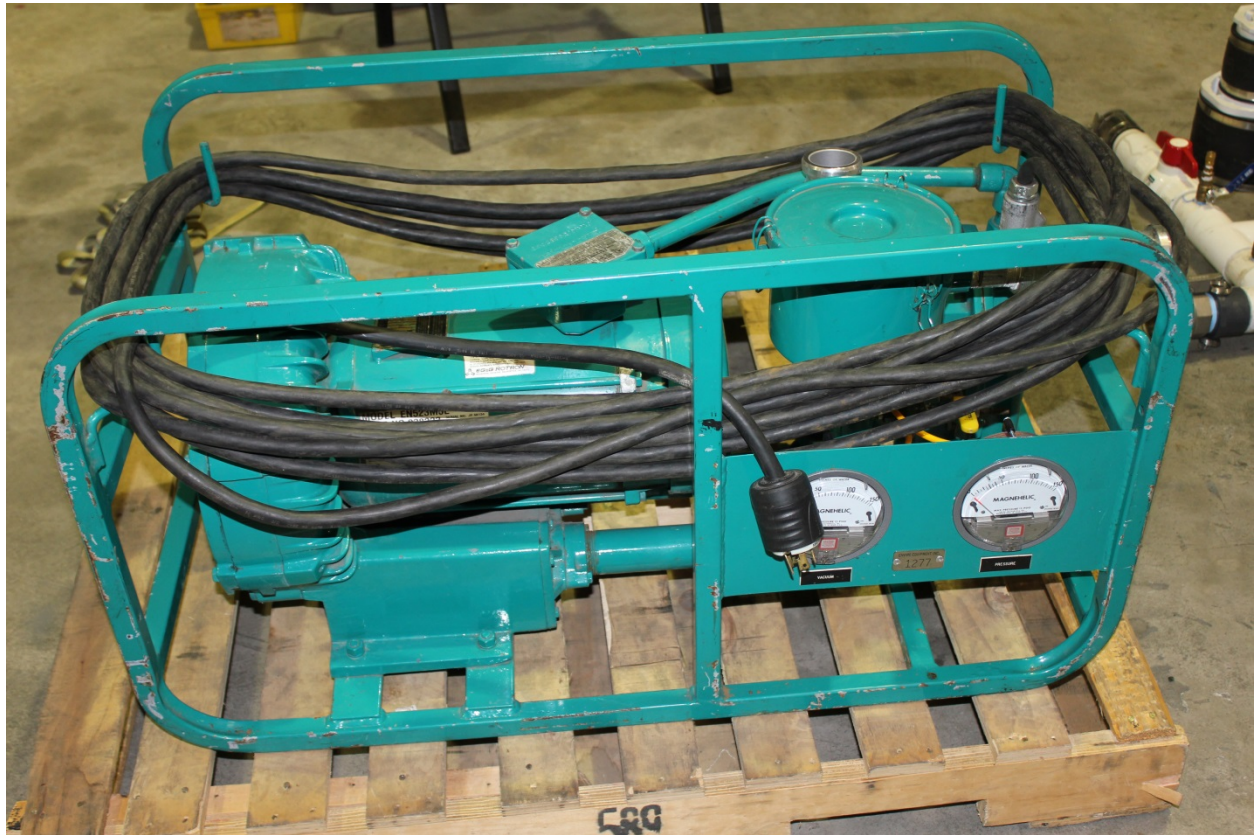



Enviro-Equipment Inc.
10120 Industrial Drive
Pineville NC 28134





Enviro-Equipment Inc.
10120 Industrial Drive
Pineville NC 28134

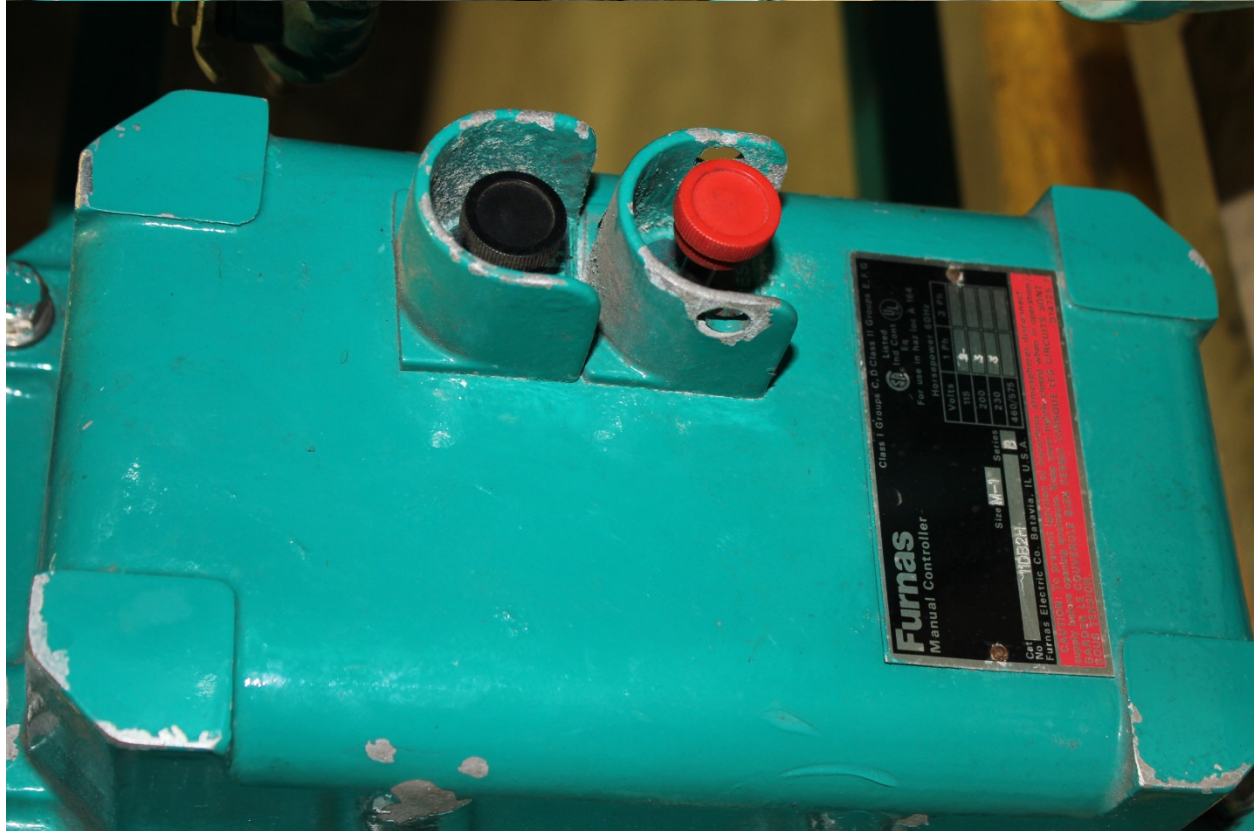

3.0 HP High Pressure Sealed Regenerative w/Explosion-Proof Motor

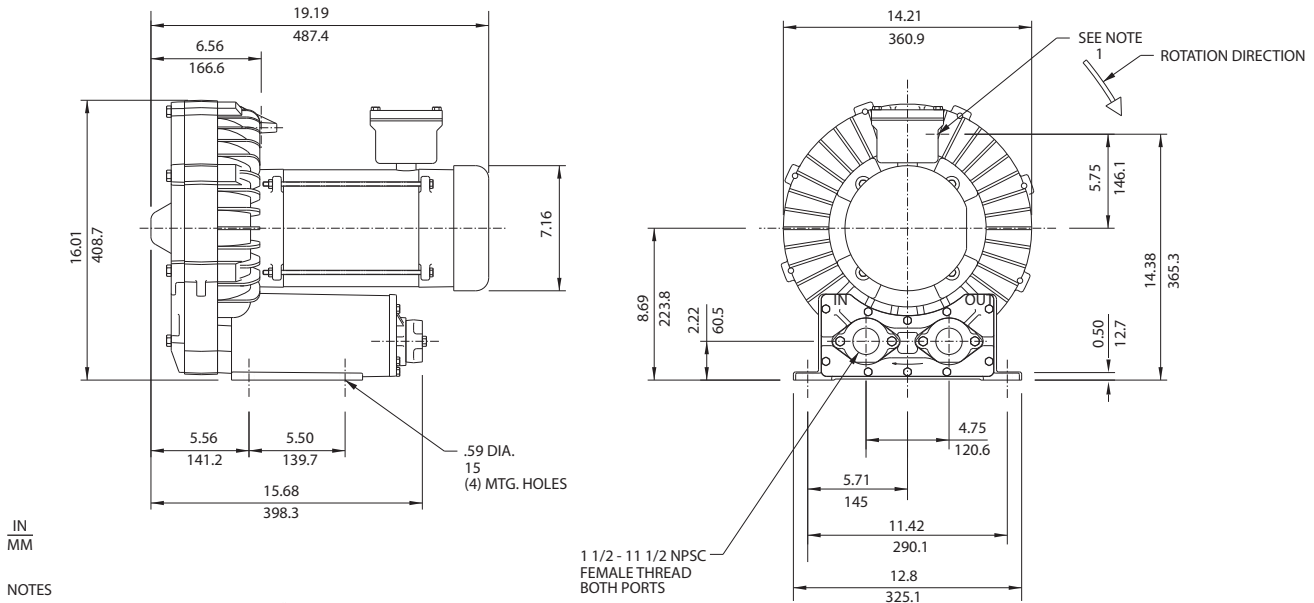

- NOTES
 1 TERMINAL BOX CONNECTOR HOLE 3/4" NPT FEMALE THREAD.
 2 DRAWING NOT TO SCALE, CONTACT FACTORY FOR SCALE CAD DRAWING.
 3 CONTACT FACTORY FOR BLOWER MODEL LENGTHS NOT SHOWN.

Specification	Units	Part/ Model Number			
		EN523M5L 038223	EN523M72L 038184	CP523FU5LR TBD	CP523FU72LR 038968
Motor Enclosure - Shaft Mtl.	-	Explosion-proof-CS	Explosion-proof-CS	Chem XP-SS	Chem XP-SS
Horsepower	-	3	3	3	3
Phase - Frequency	-	Single-60 Hz	Three-60 Hz	Single-60 Hz	Three-60 Hz
Voltage	AC	230	230/460	230	230/460
Motor Nameplate Amps	Amps (A)	15.5-14.5	7.4/3.7	15.5-14.5	7.4/3.7
Max. Blower Amps	Amps (A)	18.1-16.7	8/4	18.1-16.7	8/4
Inrush Amps	Amps (A)	94-88	62/31	94-88	62/31
Service Factor	-	1.0	1.0	1.0	1.0
Starter Size	-	1	0/0	1	0/0
Thermal Protection	-	Class B - Pilot Duty	Class B - Pilot Duty	Class B - Pilot Duty	Class B - Pilot Duty
XP Motor Class - Group	-	I-D	I-D	I-D	I-D
Shipping Weight	Lbs	126	126	150	126
	Kg	57.2	57.2	68	57.2

Voltage - ROTRON motors are designed to handle a broad range of world voltages and power supply variations. Our dual voltage 3 phase motors are factory tested and certified to operate on both: **208-230/415-460 VAC-3 ph-60 Hz** and **190-208/380-415 VAC-3 ph-50 Hz**. Our dual voltage 1 phase motors are factory tested and certified to operate on both: **104-115/208-230 VAC-1 ph-60 Hz** and **100-110/200-220 VAC-1 ph-50 Hz**. All voltages above can handle a ±10% voltage fluctuation. Special wound motors can be ordered for voltages outside our certified range.

Operating Temperatures - Maximum operating temperature: Motor winding temperature (winding rise plus ambient) should not exceed 140°C for Class F rated motors or 120°C for Class B rated motors. Blower outlet air temperature should not exceed 140°C (air temperature rise plus inlet temperature). Performance curve maximum pressure and suction points are based on a 40°C inlet and ambient temperature. Consult factory for inlet or ambient temperatures above 40°C.

Maximum Blower Amps - Corresponds to the performance point at which the motor or blower temperature rise with a 40°C inlet and/or ambient temperature reaches the maximum operating temperature.

XP Motor Class - Group - See Explosive Atmosphere Classification Chart in Section I

This document is for informational purposes only and should not be considered as a binding description of the products or their performance in all applications. The performance data on this page depicts typical performance under controlled laboratory conditions. AMETEK is not responsible for blowers driven beyond factory specified speed, temperature, pressure, flow or without proper alignment. Actual performance will vary depending on the operating environment and application. AMETEK products are not designed for and should not be used in medical life support applications. AMETEK reserves the right to revise its products without notification. The above characteristics represent standard products. For product designed to meet specific applications, contact AMETEK Technical & Industrial Products Sales department.

3.0 HP High Pressure Sealed Regenerative w/Explosion-Proof Motor

FEATURES

- Manufactured in the USA - ISO 9001 and NAFTA compliant
- Maximum flow: 84 SCFM
- Maximum pressure: 140 IWG
- Maximum vacuum: 135 IWG
- Standard motor: 3.0 HP, explosion-proof
- Cast aluminum blower housing, impeller, cover & manifold; cast iron flanges (threaded); teflon® lip seal
- UL & CSA approved motor with permanently sealed ball bearings for explosive gas atmospheres Class I Group D minimum
- Sealed blower assembly
- Quiet operation within OSHA standards

MOTOR OPTIONS

- International voltage & frequency (Hz)
- Chemical duty, high efficiency, inverter duty or industry-specific designs
- Various horsepower for application-specific needs

BLOWER OPTIONS

- Corrosion resistant surface treatments & sealing options
- Remote drive (motorless) models
- Slip-on or face flanges for application-specific needs

ACCESSORIES

- Flowmeters reading in SCFM
- Filters & moisture separators
- Pressure gauges, vacuum gauges, & relief valves
- Switches - air flow, pressure, vacuum, or temperature
- External mufflers for additional silencing
- Air knives (used on blow-off applications)
- Variable frequency drive package



Blower Performance at Standard Conditions

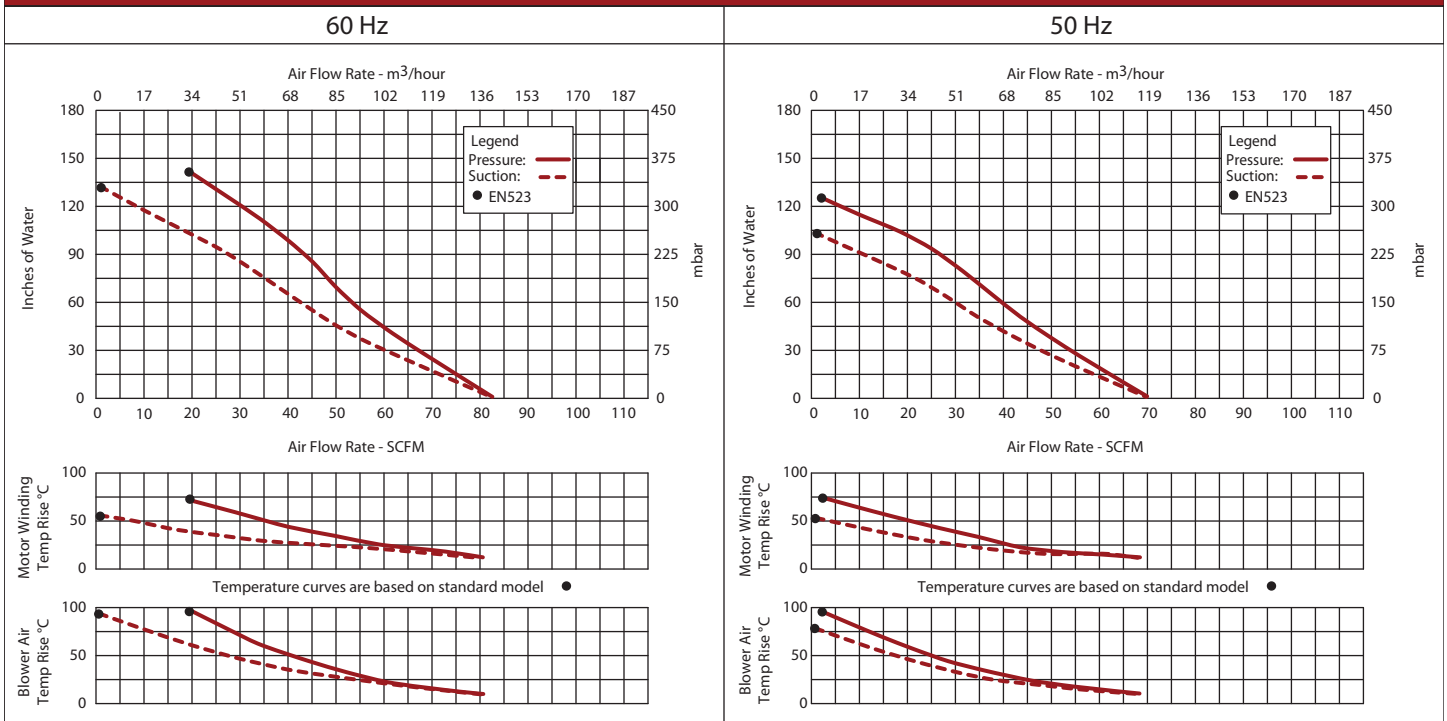

This document is for informational purposes only and should not be considered as a binding description of the products or their performance in all applications. The performance data on this page depicts typical performance under controlled laboratory conditions. AMETEK is not responsible for blowers driven beyond factory specified speed, temperature, pressure, flow or without proper alignment. Actual performance will vary depending on the operating environment and application. AMETEK products are not designed for and should not be used in medical life support applications. AMETEK reserves the right to revise its products without notification. The above characteristics represent standard products. For product designed to meet specific applications, contact AMETEK Technical & Industrial Products Sales department.

SERVICE AND PARTS MANUAL FOR BLOWER MODEL

EN454 – EN656



ROTRON Industrial Products

627 lake Street, Kent, ohio 44240 U.S.A.

Telephone: 330-673-3452 Fax: 330-677-3306

e-mail: rotronindustrial@ametek.com

internet: www.ametektip.com

Your Choice. Our Commitment.™

WARRANTY, INSTALLATION, MAINTENANCE AND TROUBLESHOOTING INSTRUCTIONS



TECHNICAL AND INDUSTRIAL PRODUCTS

627 Lake Street, Kent, Ohio 44240 USA

Telephone: 330-673-3452 Fax: 330-677-3306

e-mail: rotronindustrial@ametek.com web site: www.ametektip.com

1. AMETEK Rotron DR, EN and HiE regenerative direct drive blowers are guaranteed for one full year from the date of installation (limited to 18 months from the date of shipment) to the original purchaser only. Should the blower fail we will evaluate the failure. If failure is determined to be workmanship or material defect related, we will at our option repair or replace the blower.
2. AMETEK Rotron Minispiral, Revaflow, Multiflow, Nautilair, remote drive blowers, moisture separators, packaged units, CP blowers, Nasty Gas™ models and special built (EO) products are guaranteed for one full year from date of shipment for workmanship and material defect to the original purchaser only. Should the blower fail, If failure is determined to be workmanship or material defect related, we will at our option repair or replace the blower.
3. **Parts Policy** - AMETEK Rotron spare parts and accessories are guaranteed for three months from date of shipment for workmanship and material defect to the original purchaser only. If failure is determined to be workmanship or material defect related we will at our option repair or replace the part.

Corrective Action - A written report will be provided indicating reason(s) for failure, with suggestions for corrective action. Subsequent customer failures due to abuse, misuse, misapplication or repeat offense will not be covered. AMETEK Rotron will then notify you of your options. Any failed unit that is tampered with by attempting repair or diagnosis will void the warranty, unless authorized by the factory.

Terms and Conditions - Our warranty covers repairs or replacement of regenerative blowers only, and will not cover labor for installation, outbound and inbound shipping costs, accessories or other items not considered integral blower parts. Charges may be incurred on products returned for reasons other than failures covered by their appropriate warranty. Out-of-warranty product and in warranty product returned for failures determined to be caused by abuse, misuse, or repeat offense will be subject to an evaluation charge. Maximum liability will in no case exceed the value of the product purchased. Damage resulting from mishandling during shipment is not covered by this warranty. It is the responsibility of the purchaser to file claims with the carrier. Other terms and conditions of sale are stated on the back of the order acknowledgement.

Installation Instructions for SL, DR, EN, CP, and HiE Series Blowers

1. **Bolt It Down** - Any blower must be secured against movement prior to starting or testing to prevent injury or damage. The blower does not vibrate much more than a standard electric motor.
2. **Filtration** - All blowers should be filtered prior to starting. Care must be taken so that no foreign material enters the blower. If foreign material does enter the blower, it could cause internal damage or may exit at extremely high velocity.

Should excessive amounts of material pass through the blower, it is suggested that the cover(s) and impeller(s) be removed periodically and cleaned to avoid impeller imbalance. Impeller

imbalance greatly speeds bearing wear, thus reducing blower life. Disassembling the blower will void warranty, so contact the factory for cleaning authorization.

- Support the Piping** - The blower flanges and nozzles are designed as connection points only and are not designed to be support members.

Caution: Plastic piping should not be used on blowers larger than 1 HP that are operating near their maximum pressure or suction point. Blower housing and nearby piping temperatures can exceed 200°F. Access by personnel to the blower or nearby piping should be limited, guarded, or marked, to prevent danger of burns.

- Wiring** - Blowers must be wired and protected/fused in accordance with local and national electrical codes. All blowers must be grounded to prevent electrical shock. Slo-Blo or time delay fuses should be used to bypass the first second of start-up amperage.
- Pressure/Suction Maximums** - The maximum pressure and/or suction listed on the model label should not be exceeded. This can be monitored by means of a pressure or suction gage (available from Rotron), installed in the piping at the blower outlet or inlet. Also, if problems do arise, the Rotron Field representative will need to know the operating pressure/suction to properly diagnose the problem.
- Excess Air** - Bleed excess air off. DO NOT throttle to reduce flow. When bleeding off excess air, the blower draws less power and runs cooler.

Note: Remote Drive (Motorless) Blowers - Properly designed and installed guards should be used on all belts, pulleys, couplings, etc. Observe maximum remote drive speed allowable. Due to the range of uses, drive guards are the responsibility of the customer or user. Belts should be tensioned using belt gauge.

Maintenance Procedure

When properly piped, filtered, and applied, little or no routine maintenance is required. Keep the filter clean. Also, all standard models in the DR, EN, CP, and HiE series have sealed bearings that require no maintenance. Bearing should be changed after 15,000 to 20,000 hours, on average. Replacement bearing information is specified on the chart below.

Bearing Part Number	Size	Seal Material	Grease	Heat Stabilized
510217 510218 510219	205 206 207	Polyacrylic	Nye Rheotemp 500 30% +/- 5% Fill	Yes – 325 F
510449 516440 516648	203 202 307	Buna N	Exxon Polyrex Grease	NO
516840 516841 516842 516843 516844 516845 516846 516847	206 207 208 210 309 310 311 313	Buna N	Exxon Polyrex Grease	NO

Troubleshooting

		POSSIBLE CAUSE	OUT OF WARRANTY REMEDY ***
IMPELLER DOES NOT TURN	Humming Sound	<ol style="list-style-type: none"> * One phase of power line not connected * One phase of stator winding open Bearings defective Impeller jammed by foreign material Impeller jammed against housing or cover ** Capacitor open 	<ol style="list-style-type: none"> Connect Rewind or buy new motor Change bearings Clean and add filter Adjust Change capacitor
	No Sound	<ol style="list-style-type: none"> * Two phases of power line not connected * Two phases of stator winding open 	<ol style="list-style-type: none"> Connect Rewind or buy new motor
IMPELLER TURNS	Blown Fuse	<ol style="list-style-type: none"> Insufficient fuse capacity Short circuit 	<ol style="list-style-type: none"> Use time delay fuse of proper rating Repair
	Motor Overheated Or Protector Trips	<ol style="list-style-type: none"> High or low voltage * Operating in single phase condition Bearings defective Impeller rubbing against housing or cover Impeller or air passage clogged by foreign material Unit operating beyond performance range Capacitor shorted * One phase of stator winding short circuited 	<ol style="list-style-type: none"> Check input voltage Check connections Check bearings Adjust Clean and add filter Reduce system pressure/vacuum Change capacitor Rewind or buy new motor
	Abnormal Sound	<ol style="list-style-type: none"> Impeller rubbing against housing or cover Impeller or air passages clogged by foreign material Bearings defective 	<ol style="list-style-type: none"> Adjust Clean and add filter Change bearings
	Performance Below Standard	<ol style="list-style-type: none"> Leak in piping Piping and air passages clogged Impeller rotation reversed Leak in blower Low voltage 	<ol style="list-style-type: none"> Tighten Clean Check wiring Tighten cover, flange Check input voltage
<p>* 3 phase units ** 1 phase units *** Disassembly and repair of new blowers or motors will void the Rotron warranty. Factory should be contacted prior to any attempt to field repair an in-warranty unit.</p>			

Blower Disassembly:

WARNING: Attempting to repair or diagnose a blower may void Rotron's warranty. It may also be difficult to successfully disassemble and reassemble the unit.

- 1) Disconnect the power leads. **CAUTION:** Be sure the power is disconnected before doing any work whatsoever on the unit.
- 2) Remove or separate piping and/or mufflers and filters from the unit.
- 3) Remove the cover bolts and then the cover. **NOTE:** Some units are equipped with seals. It is mandatory that these seals be replaced once the unit has been opened.
- 4) Remove the impeller bolt and washers and then remove the impeller. **NOTE:** Never pry on the edges of the impeller. Use a puller as necessary.
- 5) Carefully note the number and location of the shims. Remove and set them aside. **NOTE:** If the disassembly was for inspection and cleaning the unit may now be reassembled by reversing the above steps. If motor servicing or replacement and/or impeller replacement is required the same shims may not be used. It will be necessary to re-shim the impeller according to the procedure explained under assembly.

- 6) Remove the housing bolts and remove the motor assembly (arbor/housing on remote drive models).
- 7) Arbor disassembly (Applicable on remote drive models only):
 - a) Slide the bearing retraining sleeve off the shaft at the blower end.
 - b) Remove the four (4) screws and the bearing retaining plate from the blower end.
 - c) Lift the shaft assembly far enough out of the arbor to allow removal of the blower end snap ring.
 - d) Remove the shaft assembly from the arbor.
 - e) If necessary, remove the shaft dust seal from the pulley end of the arbor.

Muffler Material Replacement:

- 1) Remove the manifold cover bolts and them manifold cover.
- 2) The muffler material can now be removed and replaced if necessary. On blowers with fiberglass acoustical wrap the tubular retaining screens with the fiberglass matting before sliding the muffler pads over the screens.
- 3) Reassemble by reversing the procedure.

NOTE: On DR068 models with tubular mufflers it is necessary to remove the cover and impeller accessing the muffler material from the housing cavity.

Blower Reassembly:

- 1) Place the assembled motor (assembled arbor assembly for remote drive models) against the rear of the housing and fasten with the bolts and washer.
- 2) To ensure the impeller is centered within the housing cavity re-shim the impeller according to the procedure outlined below.
- 3) If blower had a seal replace the seal with a new one.
- 4) Place the impeller onto the shaft making sure the shaft key is in place and fasten with the bolt, washer and spacer as applicable. Torque the impeller bolt per the table below. Once fastened carefully rotate the impeller to be sure it turns freely.
- 5) Replace the cover and fasten with bolts.
- 6) Reconnect the power leads to the motor per the motor nameplate.

Bolt Size	Torque Pound-Force-Foot
1/4-20	6.25 +/- 0.25
5/16-18	11.5 +/- 0.25
3/8-16	20.0 +/- 0.5
1/2-13	49.0 +/- 1
5/8 -11	90.0 +/- 2

Impeller Shimming Procedure:

WARNING: This unit may be difficult to shim. Extreme care may be exercised.

Tools Needed: Machinist's Parallel Bar
Vernier Caliper with depth measuring capability
Feeler gauges or depth gauge

Measure the Following:

- Distance from the flange face to the housing (A)
- Distance from the flange face to the motor shaft shoulder (B)
- Impeller Thickness (C)

Measurements (A) and (B) are made by laying the parallel bar across the housing flange face and measuring to the proper points. Each measurement should be made at three points, and the average of the readings should be used.

$$\text{Shim Thickness} = B - (A+C)/2$$

After the impeller installation (step #4 above) the impeller/cover clearance can be checked with feeler gauges, laying the parallel bar across the housing flange face. This clearance should nominally be $(A-C)/2$.

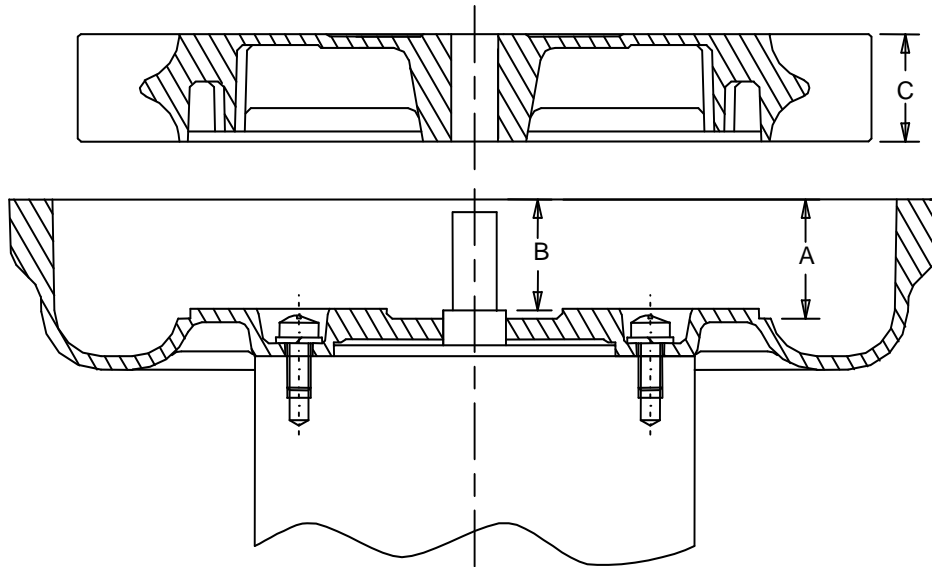



ROTRON TECHNICAL MOTOR DIVISION
REGENERATIVE BLOWER GROUP

75 North Street
Saugerties, New York 12477
Phone: (845) 246-3401
Fax: (845) 246-3802

EXPLOSION-PROOF BLOWERS



IMPORTANT: Read before wiring this Explosion-proof Blower

This AMETEK Rotron Explosion-proof Regenerative Blower may be equipped with Pilot Duty Thermal Overload (PDTO) or Automatic Thermal Overload (ATO) protection. When properly wired to a motor starter, this protection limits the motor winding temperature rise per the National Electric Code (NEC) article 500. Failure to properly wire this blower is an NEC violation and could cause an explosion. AMETEK Rotron assumes no responsibilities for damages incurred by negligent use of this product, and will not warranty a blower on which the PDTO is not properly connected. Some blowers 1 HP and under do not require PDTO and have built in ATO. Consult the factory if verification of wiring connections is required.

In all cases, follow the motor controller manufacturer's instructions. The following schematic is for conceptual understanding only, and may not apply to all motor/controller combinations.

The manufacturer's wiring diagram found on the motor takes precedent over reference diagrams supplied by AMETEK Rotron Technical Motor Division.

Schematic

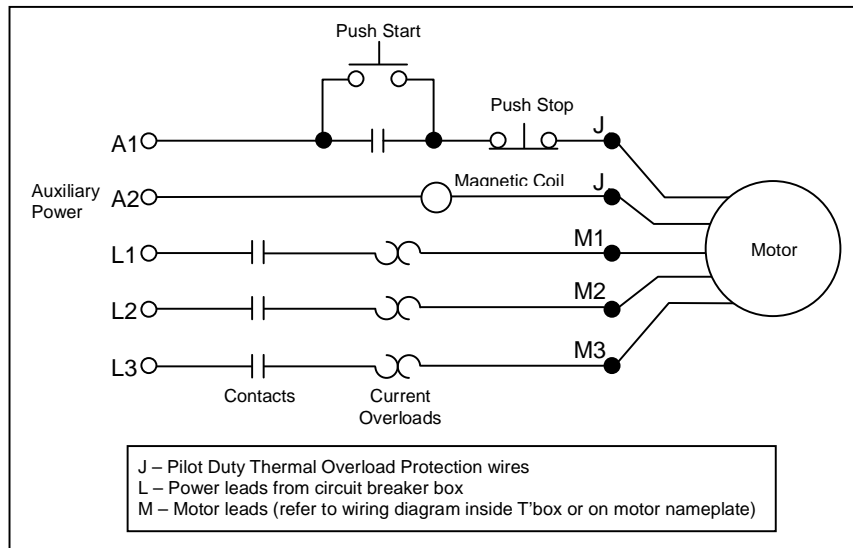

The schematic is shown for a three phase motor. For a single phase motor disregard L3 and M3. Pushing the START button completes the auxiliary control circuit, allowing current to flow through the magnetic coil. The contacts are magnetically closed, starting the motor and latching the auxiliary circuit. The motor will continue to run until the STOP push button is depressed, the motor reaches the overload temperature, or the current sensing overloads trip out.

If you have any questions, contact AMETEK Rotron at 914-246-3401 for the location of your area representative.

POLICY REGARDING INSTALLATION OF AMETEK ROTRON REGENERATIVE BLOWERS IN HAZARDOUS LOCATIONS

AMETEK Rotron will not knowingly specify, design or build any regenerative blower for installation in a hazardous, explosive location without the proper NEMA motor enclosure. AMETEK Rotron does not recognize sealed blowers as a substitute for explosion-proof motors. Sealed units with standard TEFC motors should never be utilized where local, state, and/or federal codes specify the use of explosion-proof equipment.

AMETEK Rotron has a complete line of regenerative blowers with explosion-proof motors. Division 1 & 2, Class I, Group D; Class II, Groups F & G requirements are met with these standard explosion-proof blowers.

AMETEK Rotron will not knowingly specify, design or build any regenerative blower for installation in a hazardous, corrosive environment without the proper surface treatment and sealing options.

AMETEK Rotron has a complete line of Chemical Processing and Nasty Gas™ regenerative blowers with Chem-Tough™, stainless steel parts, and seals.

AMETEK Rotron offers general application guidance; however, suitability of the particular blower selection is ultimately the responsibility of the purchaser, not the manufacturer of the blower.

FS2 Rev. B 3/10/98

WIRING DIAGRAMS, XP MOTORS

H. 1Ø, 6 WIRE

115 VAC

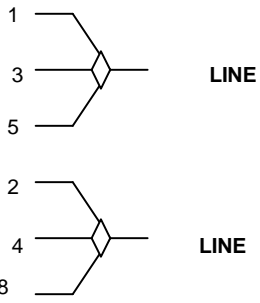

230 VAC

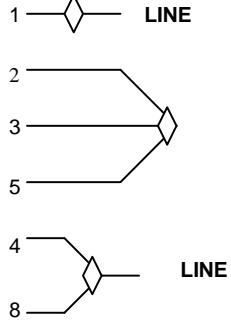

INTERCHANGE LEADWIRES 5 & 8 to REVERSE ROTATION

I. 1Ø, 7 WIRE

115 VAC

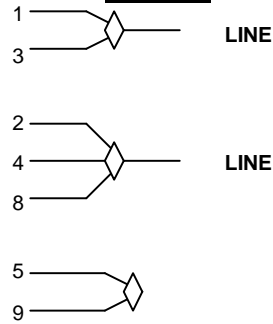

230 VAC

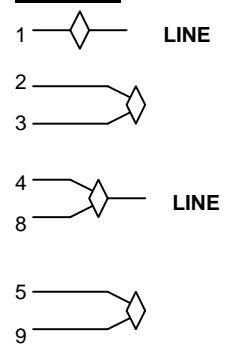

INTERCHANGE LEADWIRES 5 & 8 to REVERSE ROTATION

K. 3Ø, 9 WIRE

230 VAC

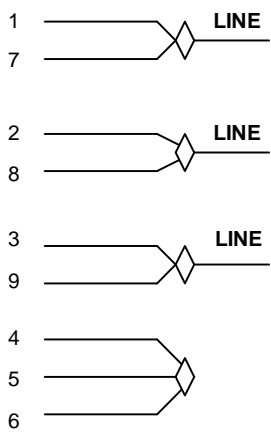

460 VAC

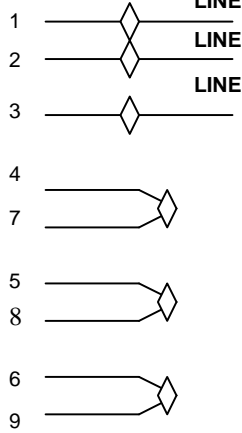

INTERCHANGE ANY TWO LEAD LINES TO REVERSE ROTATION

L. PILOT DUTY THERMAL OVERLOADS

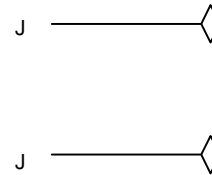

HOOK J LEADS TO CONTROL CIRCUITRY

M. 1Ø 230 VAC

SINGLE VOLTAGE

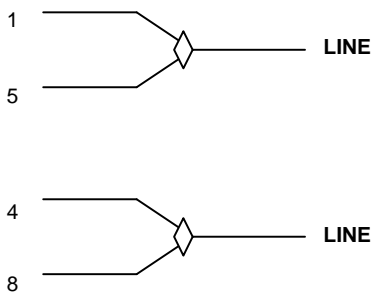

INTERCHANGE LEADWIRES 5 & 8 TO REVERSE ROTATION

N. 3Ø 575 VAC

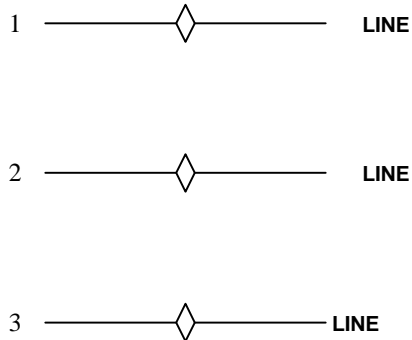

INTERCHANGE ANY TWO LEAD LINES TO REVERSE ROTATION

ASSEMBLY DIAGRAM

EN454 EN513 EN523 EN505 EN555 EN606 EN656

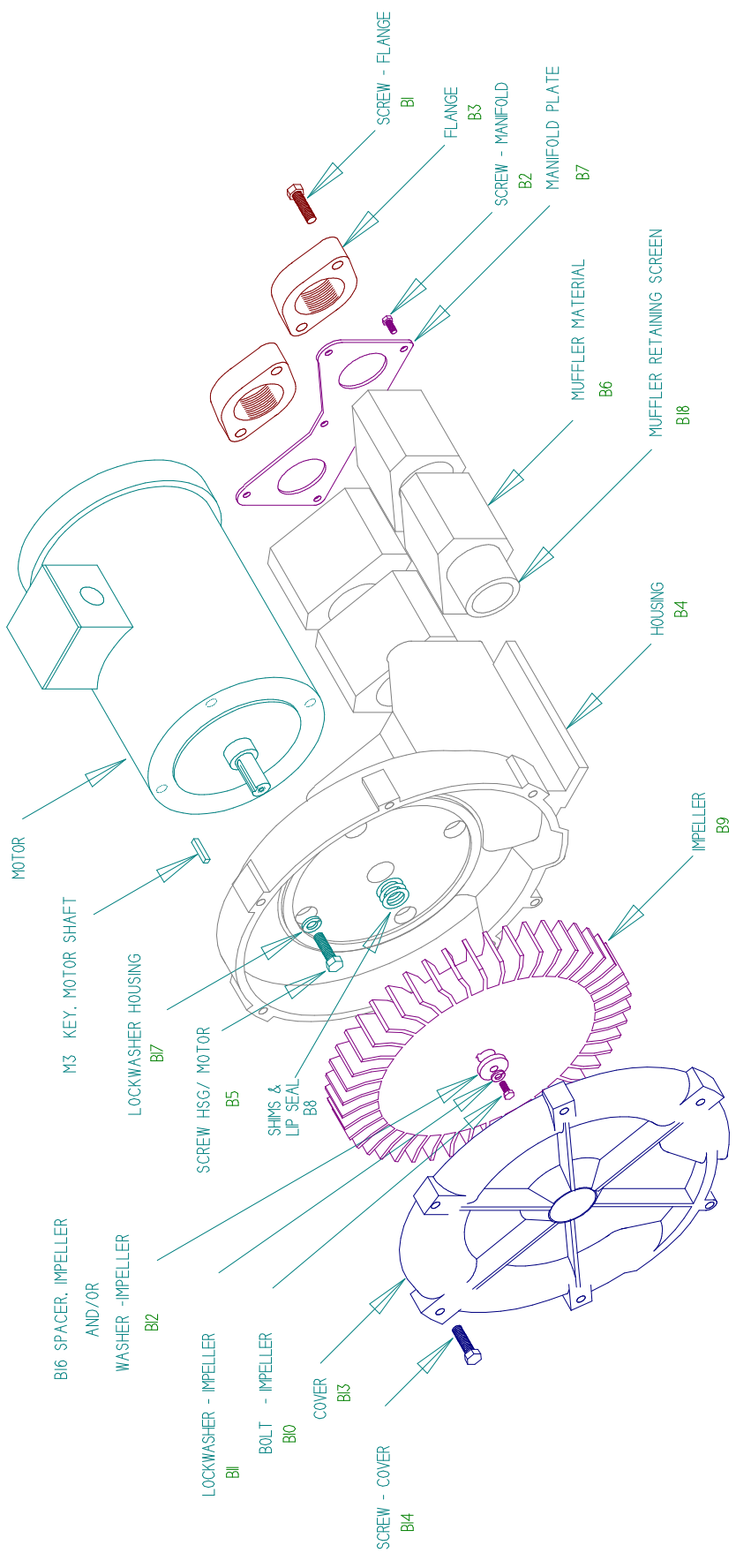

EN 454/513/523/505/555/606/656
Service and Parts Manual

Model:
 Part No.:

Parts Breakdown

EN454	EN454	EN523	EN505	EN555	EN606
038175	080487	038223	038177	038045	038179
038176	080488	038184	038178		038222
	080916		038445		038437
					038536
					038538

Item No.	Qty. Req'd	Description	EN513	EN523	EN505	EN555	EN606
M3	1	Key Motor Shaft	510629	155099	510629	510629	510629
B1	4	Screw, Flange	120162	120162	120162	120162	155095
B2	6	Screw, Manifold	155496	155170 (10 pcs)	155170	155496	155176
B3	2	Flange	510354	510354	510354	510354	511480
B4	1	Housing	515737	551001	523420	See Next Page	516721 See Next Page
B5	4	Screw, Hsg /Motor	251791	155128	251791	155128	251791
B6	4	Muffler Material	515743	515743	516560 (6 pcs)	515743	515743 See Next Page
B7	2	Muffler Insert	Not Used	551006	Not Used	Not Used	Not Used
B7	1	Manifold Plate	516410	516410	529868	517460	515482
B8	*	Shim .002"	510356	510356	510356	510356	510356
	*	Shim .005"	510357	510357	510357	510357	510357
	*	Shim .010"	510358	510358	510358	510358	510358
	*	Shim .020"	510359	510359	510359	510359	510359
	*	Shim .030"	Not Used	Not Used	Not Used	Not Used	Not Used
B9	1	Impeller	515675	551067	516557 (2 pcs)	517433	516678
B10	1	Bolt, Impeller	120214	120214	120214	120214	120262
B11	1	Lockwasher, Impeller	120203	120203	120203	120203	120203
B12		Washer, Impeller	Not Used	Not Used	Not Used	Not Used	Not Used
B13	1	Cover	517807	551065	516559	517808	516675
B14	6	Screw, Cover	155236	155129 (8 pcs)	155098 (8 pcs)	155236 (7 pcs)	155236
B16	1	Spacer, Impeller Bolt	510355	510355	510355	510355	510355
B17		Lockwasher, Housing	Not Used	Not Used	Not Used	Not Used	Not Used
B18	1	Screen, Muffler Retaining, Right (**)	510362	551087	511718	See Next Page	510362 See Next Page
B19	1	Screen, Muffler Retaining, Left (**)	510362	551087	511718	See Next Page	510362 See Next Page
B20		Muffler Hsg/Hsg	Not Used	Not Used	Not Used	Not Used	Not Used
		Muffler Housing	Not Used	Not Used	Not Used	Not Used	Not Used
		Bolt, Motor/Muffler	Not Used	Not Used	Not Used	Not Used	Not Used
		Lockwasher, Motor/Muffler	Not Used	Not Used	Not Used	Not Used	Not Used
		Washer, Motor/Muffler	Not Used	Not Used	Not Used	Not Used	Not Used
		Spacer, Motor/Muffler	Not Used	Not Used	Not Used	Not Used	Not Used
B23		Bolt, Mounting Rail	Not Used	Not Used	Not Used	Not Used	Not Used
B24		Lockwasher, Rail	Not Used	Not Used	Not Used	Not Used	Not Used
B25		Nut, Rail	Not Used	Not Used	Not Used	Not Used	Not Used
B26		Rail Mounting	Not Used	Not Used	Not Used	Not Used	Not Used
	1	Lip Seal	516587	516587	516587	516587	516587

*As needed **Viewed looking at inlet/outlet ports ***Not currently in production; superseded by model listed below

Model	Part No.	Motor	Wiring Diagram	Specific Parts	Bearing, Rear (M1)
EN454W58L	038175	515747	H + L		
EN454W72L	038176	515746	K + L		
EN454W58ML	080487	515747	H + L		
EN454W72ML	080488	515746	K + L		
EN454W86ML	080916	517391	N + L		
EN513W58L	038183	515747	H + L		
EN513W72L	038037	515746	K + L		
EN523M72L	038184	517675	K + L		510449
EN523M5L	038223	551373	M + L	B13 516555 1 pc Center Annulus	510217
EN505AX58ML	038177	510326	H + L		
EN505AX72ML	038178	510325	K + L	B4 517419	510449
EN505CJ5ML	038445	529622	M + L	B18 517435 2 pcs B4 529654	
EN555M72L	038045	516687	K + L	B18 517436 2 pcs	
EN606M72L	038179	516687	K + L		510449
EN606M5L	038222 ***	551366	M + L	B4 511276 1 pc B6 511285 4 pcs	510217
EN606M86L	038437	529630	N + L	B4 529790 1 pc	510449
EN606M72ML	038536	516687	K + L	B6 529781 4 pcs	
EN606M5ML	038538	551366	M + L	B18 529782 2 pcs	510217
EN656M86XL	080058	529630	N + L		510449
EN656M72XL	080059	516687	K + L		
EN656M5XL	080060	551366	M + L	B7 Muffler extension 551974 1 pc	510217

*As needed **Viewed looking at inlet/outlet ports ***Not currently in production; superseded by model listed below

EN656
080058
080059
080060

510629
120255
155170
511480
550195
251791
(10 pcs.) 551585
Not Used
See Next Page
510356
510357
510358
510359
Not Used
550305
120325
120203
Not Used
550249
(8 pcs.) 155236
510355
Not Used
517436
517436
Not Used
Not Used
Not Used
Not Used
Not Used
Not Used
Not Used
Not Used
Not Used
Not Used
516587

*As needed **Viewed looking at inlet/outlet ports ***Not currently in production; superseded by model listed below

Bearing, Impeller End (M2)
510217
510218
510217
510217
510218
510217
510218
510217
510218

*As needed **Viewed looking at inlet/outlet ports ***Not currently in production; superseded by model listed below

ROTRON® Regenerative Blowers

Filtration Accessories

Blower Connection Key	
NPT	American National Standard Taper Pipe Thread (Male)
NPSC	American National Standard Straight Pipe Thread for Coupling (Female)
SO	Slip On (Smooth – No Threads)

Moisture Separator™

By separating and containing entrained liquids, Rotron's moisture separator helps protect our regenerative blowers and the end treatment system from corrosion and mineralization damage. Recommended for all soil vacuum extraction applications.

SPECIFICATIONS:

SEPARATION METHOD – High Efficiency Cyclonic
 RELIEF VALVE MATERIAL – Brass & Stainless Steel
 FLOAT MATERIAL – Copper
 FLOAT SWITCH – SPDT, Explosion-proof
 NEMA 7&9, 5 Amp max.

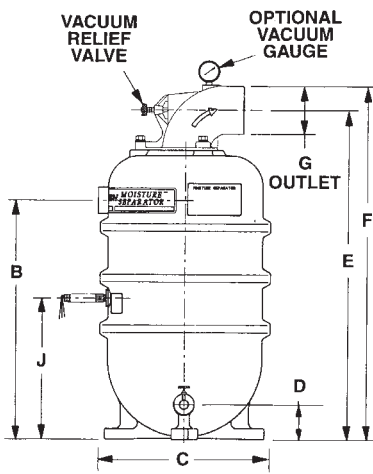
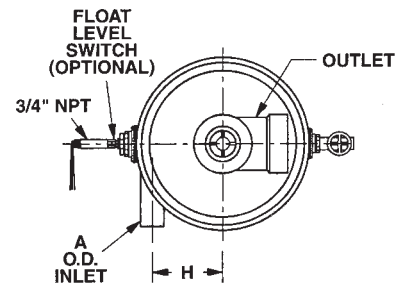
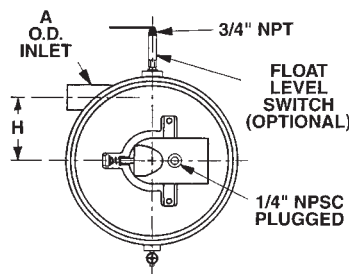
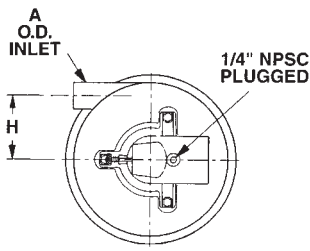

PLASTIC "P" DESIGN

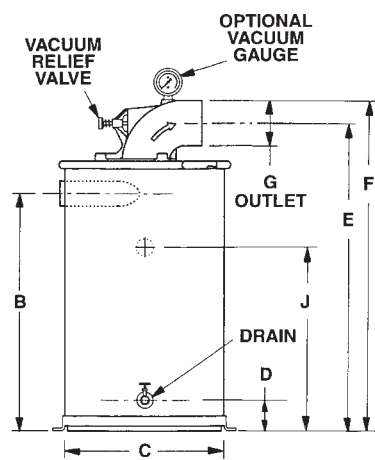

METAL "D" DESIGN

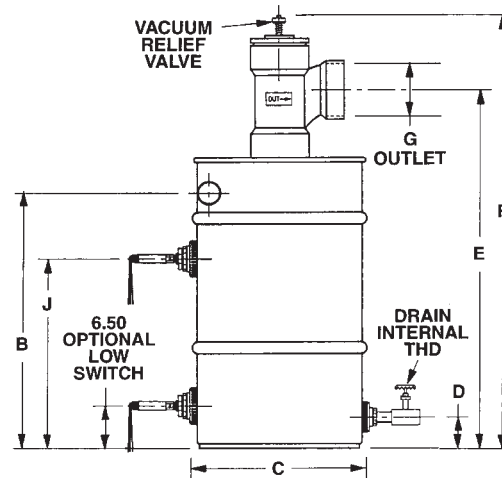

METAL "B" DESIGN

Model	Part No.	CFM Max.	A Dia.	B	C Dia.	D	E	F	G Dia.	H	J Switch	Drain Internal THD	Shipping Weight
MS200PS	038519	200	2.38	22.46	16.00	3.25	31.05	33.30	4.50 OD	6.00	13.25	3/4" NPT	42 lb.
MS300PS	038520	300	2.88							6.56	12.62		
MS200DS	080086	200	2.00	22.12	16.75	2.75	27.92	30.17		6.81			
MS300DS	080087	300	2.50										
MS350BS	038357	350	3.25	28.00	23.00	4.00	37.25	39.50	9.75	17.50	1" NPT	82 lb.	
MS500BS	080660	500					37.37	54.50				6.63 ID	9.25
MS600BS	080659	600	4.00	27.00	27.00	4.00	47.32	51.70	8.62 OD	10.00		19.88	150 lb.
MS1000BS	038914	1000	6.00	31.00									

Models without float switch available. Metal MS200/300DS models are not the standard stocked, but are available.

Rev. 2/04

ROTRON® Regenerative Blowers

Filtration Accessories

Blower Model Reference Key	
A = SPIRAL	E = DR/EN/CP 656, 6, 623, S7
B = DR/EN/CP 068, 083, 101, 202	F = DR/EN/CP 707, 808, 858, S9, P9 (Inlet Only)
C = DR/EN/CP 303, 312, 313, 353	G = DR/EN/CP 823, S13, P13 (Inlet Only)
D = DR/EN/CP 404, 454, 513, 505, 555, 523	H = DR/EN/CP 909, 979, 1223, 14, S15, P15 (Inlet Only)

2.0 Moisture Separator™ Specifications

2.1 DUTY

The moisture separator shall be designed for use in a soil vapor extraction system capable of continuous operation with a pressure drop of less than six inches of water at the rated flow of _____ SCFM. The separator shall be capable of operation under various inlet conditions ranging from a fine mist to slugs of water with high efficiency.

2.2 PRINCIPLE OF OPERATION

The moisture separator shall incorporate cyclonic separation to remove entrained water. The separator must protect against an overflow by fail safe mechanical means. An electrical switch or contact(s) alone is not an acceptable means of protection against overflow, but is a good backup.

2.3 CONSTRUCTION

The body of the moisture separator shall be constructed of heavy wall plastic or heavy gauge cold rolled steel. The steel interior and exterior shall be epoxy (powder) coated to resist abrasion, corrosion, and chipping that might expose the surface. The inlet shall be tangentially located and welded to the body. The outlet port shall be constructed of PVC or cast aluminum alloy, flanged and sealed to the center of the top of the separator. The separator shall incorporate a non-sparking copper

float ball and an adjustable relief valve to protect against overflow and overheating the blower.

2.4 CAPACITY AND DIMENSIONS

The moisture separator must have a liquid capacity of _____ gallons. The inlet shall be _____ inch OD slip-on type. The outlet shall be _____ inch OD slip-on type.

For DR/EN/CP Blower Model	Selector Moisture Separator Model	Liquid-holding Capacity (gallons)	Inlet (OD)	Outlet	Max Vacuum Allowed (IHg)
404 454 505 513 523 555 623 823	MS200PS	7	2.38	4.5" OD	12
	MS200DS	10	2.0		22
656 6 707	MS300PS MS300DS	7 10	2.88 2.5	6.63" ID	12
808	MS350BS		3.25		22
858 1223	MS500BS	40	4.0"		
909	MS600BS		4.0"		
979 14	MS1000BS	65	6.0"	8.62" OD	

2.5 PRESSURE DROP

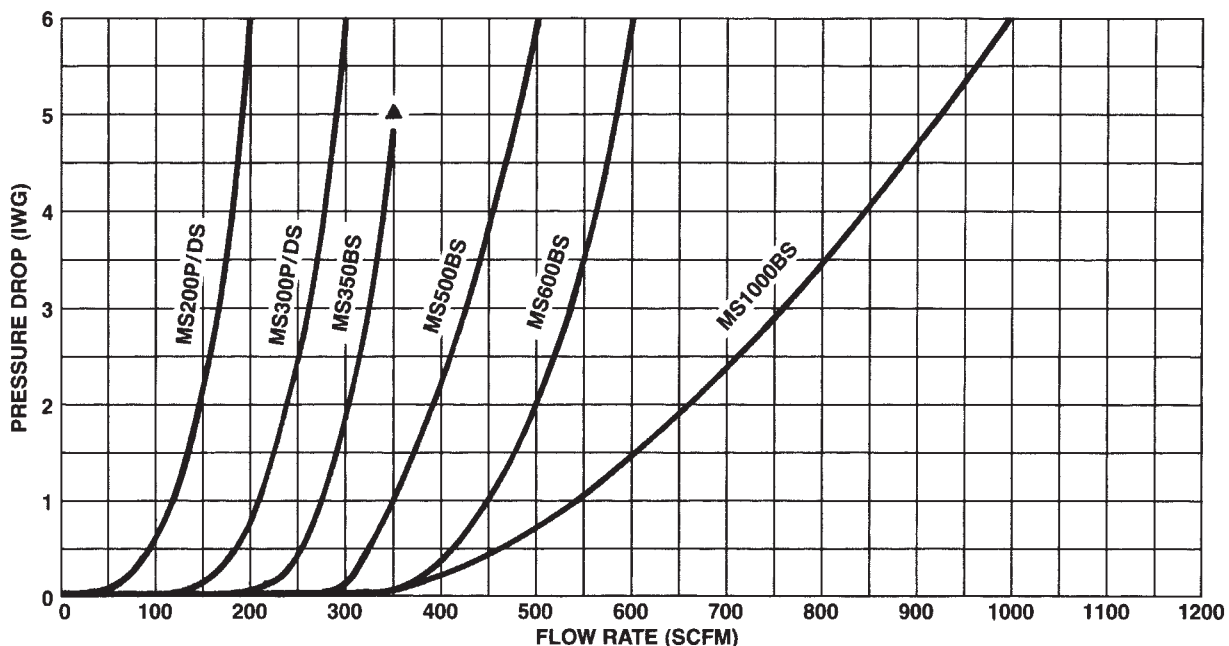



Small Compact Inlet Vacuum Filters

"CSL" Series 3/8" - 3" FPT

APPLICATIONS & EQUIPMENT

- Vacuum Pumps & Systems – P.D., Side Channel, Rotary Vane, Screw, Piston
- Vacuum Packaging Equipment
- Vacuum Lifters
- Blowers - Side Channel & P.D.
- Intake Suction Filters
- Pneumatic Conveying Systems
- Soil Venting/Remediation
- Remote Installations for Piston & Screw Compressors
- Printing Industry
- Factory Automation Equip
- Leak Detection Systems
- Woodworking
- Medical Industry

FEATURES & SPECIFICATIONS

- **Vacuum level:** Typically 1×10^{-3} mmHg (1.3×10^{-3} mbar)
- Polyester: 99%+ removal efficiency standard to 5 micron
- Paper: 99%+ removal efficiency standard to 2 micron
- Brazed fittings for **High** vacuum duty
- Stainless steel torsion clips for durability
- Low pressure drop
- Positive engagement O-ring seal system
- Seamless drawn housings
- **Large** dirt holding capacity and **Easy** field cleaning, especially when mounted horizontally or inverted
- Rugged all steel construction w/baked enamel finish
- Various media
- Temp (continuous): min -15°F (-26°C) max 220°F (104°C)
- Filter change out differential: 10" - 15" H₂O over initial delta P
- Pressure drop graphs available upon request

OPTIONS (Inquiries Encouraged)

- Vacuum gauge available
- Dome hood for high holding capacity
- Available in **Stainless Steel**
- Epoxy coated housings
- Activated carbon prefilter for odor
- Support brackets
- Alternate top-to-canister fastening system for low pressure or pulsating systems

CONFIGURATION

DRAWING

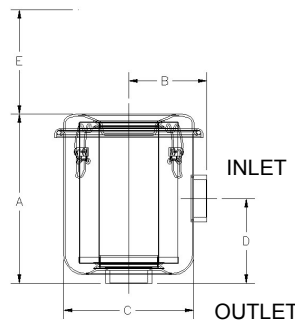

Dimension tolerance $\pm 1/4"$

I = Industrial Duty S = Severe Duty

	with Polyester Element	with Paper Element	FPT Inlet & Outlet	DIMENSIONS - inches					Rated Flow SCFM Nominal Rating	Element Rating	Approx. Wt. lbs
				A	B	C	D	E			
I	CSL-825-039HC	CSL-824-039HC	3/8"	3 5/8	2 1/4	3 3/4	1 7/8	3	18	25	0.88
I	CSL-825-050HC	CSL-824-050HC	1/2"	3 5/8	2 1/4	3 3/4	1 7/8	3	18	25	0.88
I	CSL-843-050HC	CSL-842-050HC	1/2"	4 3/8	3	5 7/8	2 1/2	3 1/4	20	55	3
I	CSL-825-075HC	CSL-824-075HC	3/4"	3 3/4	2 1/4	3 3/4	1 7/8	3	24	25	0.88
S	CSL-843-075HC	CSL-842-075HC	3/4"	4 3/8	3	5 7/8	2 1/2	3 1/4	25	55	3
I	CSL-843-100HC	CSL-842-100HC	1"	4 3/8	3 1/4	5 7/8	2 5/8	3 1/4	35	55	3
S	CSL-849-100HC	CSL-848-100HC	1"	6 3/4	4 1/8	7 5/16	4 1/2	5 1/4	40	115	5
I	CSL-843-125HC	CSL-842-125HC	1 1/4"	4 3/8	3 1/4	5 7/8	2 5/8	3 1/4	55	55	3
S	CSL-849-125HC	CSL-848-125HC	1 1/4"	6 3/4	4 1/8	7 5/16	4 1/2	5 1/4	60	115	5
I	CSL-849-150HC	CSL-848-150HC	1 1/2"	6 3/4	4 1/8	7 5/16	4 1/2	5 1/4	80	115	5
I	CSL-851-200HC	CSL-850-200HC	2"	10 1/4	4 9/16	8 3/4	5	9 1/4	175	290	15
I	CSL-851-250HC	CSL-850-250HC	2 1/2"	10 1/2	5 1/8	8 3/4	5 1/2	9 1/4	210	290	15
I	CSL-239-300C*	CSL-238-300C*	3"	15 3/4	8 7/8	13 1/4	8 3/4	11	300	570	33

*1/4" taps standard on inlet and outlet

Note: Model offerings and design parameters may change without notice.

Solberg – Discover the Possibilities

CSL14-7162

1151 Ardmore Ave. • Itasca, IL 60143 USA

Sales/Service: 630.773.1363 • Fax: 630.773.0727

E-mail: sales@solbergmfg.com • Web Site: www.solbergmfg.com

INLET VACUUM FILTERS
CSL, ST, CT, VL, VS, LRS Series