

Sealed Regenerative Blower w/Explosion-proof Motor

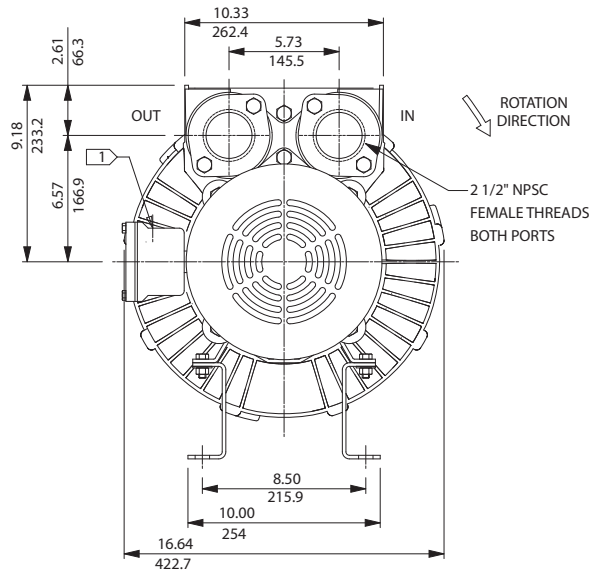
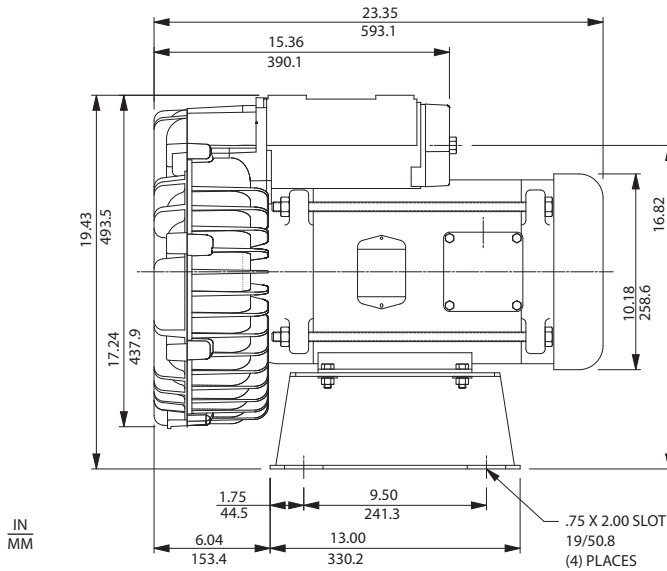

NOTES

- 1 TERMINAL BOX CONNECTOR HOLE 3/4" NPT FEMALE THREAD.
- 2 DRAWING NOT TO SCALE, CONTACT FACTORY FOR SCALE CAD DRAWING.
- 3 CONTACT FACTORY FOR BLOWER MODEL LENGTHS NOT SHOWN.

		Part/Model Number	
		EN757FL5MWL	CP757FX5MWLR
Specification	Units	081333	080616
Motor Enclosure - Shaft Mt.	-	Explosion-proof-CS	CHEM XP-SS
Horsepower	-	5.5	5.5
Phase - Frequency	-	Single-60 hz	Single-60 hz
Voltage	AC	230	230
Motor Nameplate Amps	Amps (A)	21.7	21.7
Max. Blower Amps	Amps (A)	29.9	29.9
Locked Rotor Amps	Amps (A)	155	155
Service Factor	-	1	1
Starter Size	-	1.0	1.0
Thermal Protection	-	Class B - Pilot Duty	Class B - Pilot Duty
XP Motor Class - Group	-	I-D	I-D
Shipping Weight	Lbs	158	158
	Kg	71.7	71.7

**Voltage** - ROTRON motors are designed to handle a broad range of world voltages and power supply variations. Our dual voltage 3 phase motors are factory tested and certified to operate on both: **208-230/415-460 VAC-3 ph-60 Hz** and **190-208/380-415 VAC-3 ph-50 Hz**. Our dual voltage 1 phase motors are factory tested and certified to operate on both: **104-115/208-230 VAC-1 ph-60 Hz** and **100-110/200-220 VAC-1 ph-50 Hz**. All voltages above can handle a ±10% voltage fluctuation. Special wound motors can be ordered for voltages outside our certified range.

**Operating Temperatures** - Maximum operating temperature: Motor winding temperature (winding rise plus ambient) should not exceed 140°C for Class F rated motors or 120°C for Class B rated motors. Blower outlet air temperature should not exceed 140°C (air temperature rise plus inlet temperature). Performance curve maximum pressure and suction points are based on a 40°C inlet and ambient temperature. Consult factory for inlet or ambient temperatures above 40°C.

**Maximum Blower Amps** - Corresponds to the performance point at which the motor or blower temperature rise with a 40°C inlet and/or ambient temperature reaches the maximum operating temperature.

**XP Motor Class - Group** - See Explosive Atmosphere Classification Chart in Section I

This document is for informational purposes only and should not be considered as a binding description of the products or their performance in all applications. The performance data on this page depicts typical performance under controlled laboratory conditions. AMETEK is not responsible for blowers driven beyond factory specified speed, temperature, pressure, flow or without proper alignment. Actual performance will vary depending on the operating environment and application. AMETEK products are not designed for and should not be used in medical life support applications. AMETEK reserves the right to revise its products without notification. The above characteristics represent standard products. For product designed to meet specific applications, contact AMETEK Technical & Industrial Products Sales department.

Sealed Regenerative Blower w/Explosion-proof Motor

## FEATURES

- Manufactured in the USA - ISO 9001 and NAFTA compliant
- Maximum flow: 310 SCFM
- Maximum pressure: 80 IWG
- Maximum vacuum: 75 IWG
- Standard motor: 5.0 HP, explosion-proof
- Cast aluminum blower housing, impeller, cover & manifold; cast iron flanges (threaded); teflon® lip seal
- UL & CSA approved motor with permanently sealed ball bearings for explosive gas atmospheres Class I Group D minimum
- Sealed blower assembly
- Quiet operation within OSHA standards

## MOTOR OPTIONS

- International voltage & frequency (Hz)
- Chemical duty, high efficiency, inverter duty or industry-specific designs
- Various horsepowers for application-specific needs

## BLOWER OPTIONS

- Corrosion resistant surface treatments & sealing options
- Remote drive (motorless) models
- Slip-on or face flanges for application-specific needs

## ACCESSORIES

- Flowmeters reading in SCFM
- Filters & moisture separators
- Pressure gauges, vacuum gauges, & relief valves
- Switches - air flow, pressure, vacuum, or temperature
- External mufflers for additional silencing
- Air knives (used on blow-off applications)
- Variable frequency drive package

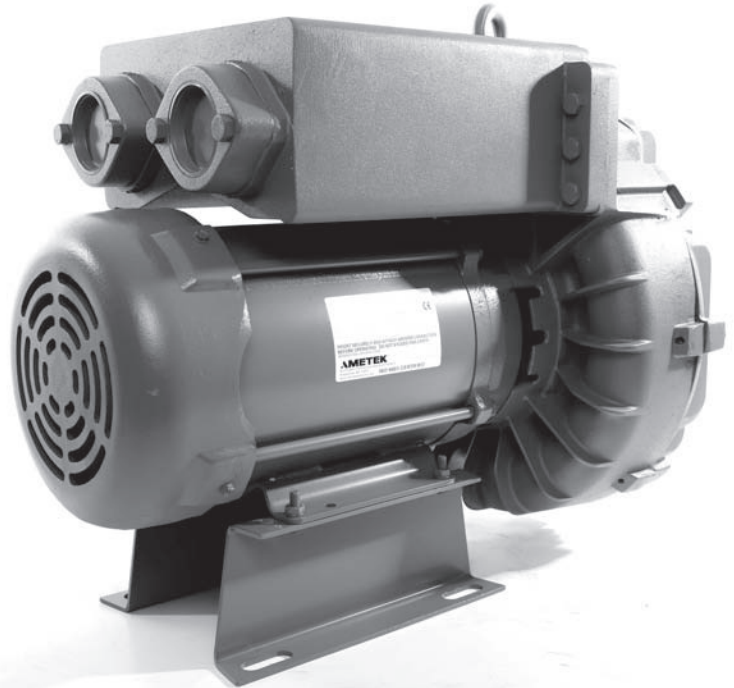

## Blower Performance at Standard Conditions

60 Hz

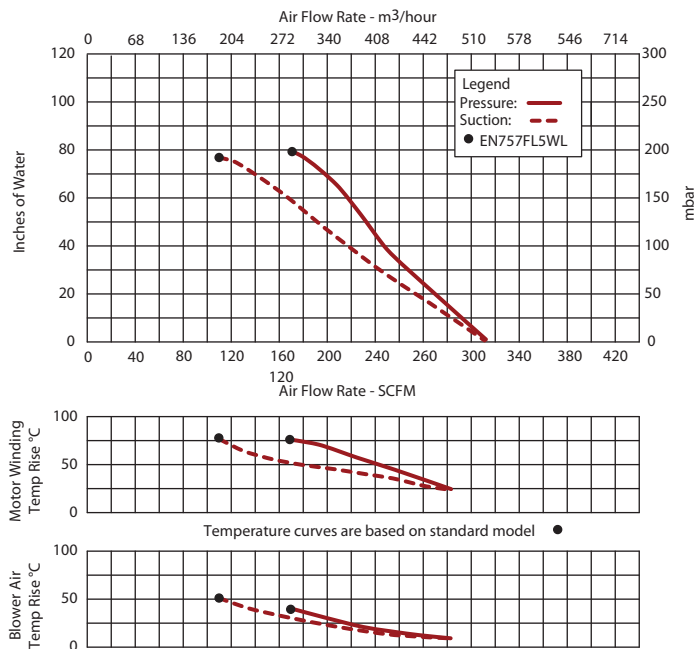

This document is for informational purposes only and should not be considered as a binding description of the products or their performance in all applications. The performance data on this page depicts typical performance under controlled laboratory conditions. AMETEK is not responsible for blowers driven beyond factory specified speed, temperature, pressure, flow or without proper alignment. Actual performance will vary depending on the operating environment and application. AMETEK products are not designed for and should not be used in medical life support applications. AMETEK reserves the right to revise its products without notification. The above characteristics represent standard products. For product designed to meet specific applications, contact AMETEK Technical & Industrial Products Sales department.