

The
STRAINRITE
Companies
World Class Filtration

Filter Bags

Cartridges

Vessels

FILTRATION

Manufacturers of



Welcome to



Our ISO 9001 certified world class manufacturing capabilities and depth of product offerings combined with sales professionals covering the entire United States makes us a powerful market leader. Our "Value Proposition" is to provide our client with the best available solutions that reduce their total cost of ownership. Some benefits our clients receive from this win-win relationship include:

- Realized Operational Cost Savings
- Improved Process Efficiency
- Enhanced Finished Product Quality
- Reduced Waste Costs
- Comprehensive Cost Analysis Considering All Aspects of Your Application

In order to realize these benefits, our highly trained outside field sales professionals and distributors commit time and energy to understand your particular needs. The company representative will then, with the support of our in-house technical staff, provide a needs assessment outlining which Strainrite product, service, or combination will add unparalleled value to your company.

Our consultative selling approach focuses on forming long-term business partnerships with companies who want a supplier that provides innovative products and services. Call our corporate office today, a member of our technical support team will provide you with detailed information about how a relationship with The Strainrite Companies can benefit your firm.



The Strainrite Companies

Capabilities

The Strainrite Companies years of experience in the filtration industry offer clients the best liquid filtration solutions. We provide a complete line of standard filter bag products and can design a specific product to meet customer needs.

We continue with extensive Research and Development of new filtration products to add value for our customers. We have introduced a number of extremely successful specialty filter product lines.

Our engineers design and build a full line of quality liquid filter vessels to handle a variety of filtration applications. Using state of the art CAD equipment operated by skilled design engineers, we provide high quality, accurate engineering drawings. These drawings are produced in house and are available in A,B, C,or D sizes.

Our metal fabrication shop produces several standard design vessels to handle flow rates between 10 gpm at 4,500 gpm at pressure ratings ranging from 75 to 1500 PSI. For special system requirements, our engineers will custom design a system for you

Standard design filter vessels are constructed from the highest quality carbon steel, 304 or 316 stainless steel and conform to ASME code standards.

We have made and continue to make significant investments in human and business assets allowing us to offer world class products and services. We have made two strategic acquisitions in recent years that have substantially increased our product offering, added a second manufacturing location (in Michigan) and improved client services. In January of 2001, The Strainrite Companies moved into a brand new \$3.8 million, 83,000 sq. ft. manufacturing facility. This facility houses over half a million dollars of the latest technologically advanced high speed manufacturing equipment available and was built from the ground up as a silicon-free facility.



Since 1975 in Santa Fe Springs, CA



The Strainrite Companies

Strainrite has plants in the Northeast, Mid-West and on the West coast, in addition to the offices in NJ, GA and TN. Distributors are located throughout North America as well as Europe and the Far East. The combined capabilities and approvals in automotive, paints, coatings, adhesives, plating, inks & chemicals make The Strainrite Companies a great choice for your filtration partner. Call us today!

Nationwide Toll Free 800-487-3136



For over 26 years. Now located in Pontiac, MI.



www.strainrite.com

ISO 9001

Intertek Systems Certification

Certificate of Registration

This is to certify that the Quality Management System of:

The Strainrite Companies

65 First Flight Drive, Auburn, Maine, 04210, USA

has been assessed and registered by Intertek Testing Services NA, Inc.
as conforming to the requirements of the following standard(s):

ISO 9001:2000

The Quality Management System is applicable to:

**The design and manufacture of industrial filtration products and industrial pressure vessels.
The distribution of filtration and environmental products and vessel accessories.**



Certificate No. **US-2225b**
Project No. **009350**

A handwritten signature in black ink, appearing to read "K. Minard".

Intertek Testing Services NA, Inc.
Buxborough, MA, USA

The approval is subject to the organization maintaining their system in accordance with Intertek Testing Services NA, Inc.'s rules and regulations for certification. This certificate is valid as long as the company name appears on our website: www.intertek-sc.com.



Initial Date	March 5, 2003
Issue Date	August 7, 2006
Renewal Date	April 21, 2009

The Quality Management Systems of U.F. Strainrite are certified to ISO 9001:1994

Table of Contents

Page	Topic
2	Introduction & Welcome
4	ISO 9001 Certificate
5	Table of Contents
6	Standard Filter Bags
7	How to Order Standard Filter Bags
8	Hi-Pro Micro Bags (HPM)
10	Absorbrite and Oil Log
11	Mag Bag and Carbon Ready Bag
12	Aqua-Rite Potable Drinking Water Filtration
14	Valu-Life Filter Bags
15	String Wound Cartridges
16	Resin Bonded Cartridges
17	Melt Blown Cartridges
18	Pleated Cartridges

We reserve the right to limit quantities, correct typographical errors and change prices if necessary.

Shipping Policy: We will be pleased to try to accommodate your carrier of choice. We currently warehouse product in several locations throughout the USA. We are able to use most shipping carriers.

Damages in shipment: Product sometimes can be damaged during transportation. The carrier is liable for all damages only when indicated on the bill of lading by the receiver. Please inspect all shipments received. Please note damage upon receipt, keep shipping package and inner contents. Request carrier to inspect.

For assistance, contact our customer care advocates by calling 800-487-3136 or sending Email to info@strainrite.com. Returns: Call our customer care advocates for return authorization numbers. We cannot accept return packages without an RA number assigned and marked on the package. Restocking charges may apply.

Standard Filter Bags

Strainrite provides the most complete range of standard liquid filter bags available in the marketplace today. High quality products for almost every application and efficiency requirement imaginable, Strainrite manufactures filter bags to fit not only their own high quality filter housings, but also those of other manufacturers. The complete line of conventional filter bags are available in a wide range of sizes and materials.

BASIC MATERIALS:

FELT: A versatile fabric available in numerous micron ratings. Felt's three dimensional construction creates a fabric with low density and high permeability. These features offer longer life bags with greater flow rates and increased dirt holding capacity. Unlike woven fabrics with low permeability (only 20-30 percent useable surface area), felts provide depth for greater particle retention

and generally the best cost per gallon filter bag on the market today. Felt fabrics include: Polyester, Polypropylene, Nylon, Viscous, Teflon and Nomex.

MULTIFILAMENT MESH: This low cost, disposable woven material is available in a wide range of micron ratings. Good in applications where felt is not suitable.

MONOFILAMENT MESH: This woven material is both strong and efficient and offers many micron ranges where felt is not available.

With advanced manufacturing capabilities, Strainrite can provide the perfect replacement filter bag for your particular application. Call our Customer Service department for assistance. We offer experienced technical support for all of your questions about liquid filtration.

Acids	Giardia cysts
Adhesives	Hydraulic liquids
Alkalines	Inks
Alcohols	Machinery cooling liquids
Amines	liquids
Beverages	Magnetic coatings
Beer	Membrane protection
Chemicals	Mineral oils
Coating Products	Oil & gas industry
Cooling Water	Paints
Cosmetics	Pharmaceuticals
Drinking Water	Photochemicals
E-coats	Process water
EDM - oils	Resins
Electroplating solutions	Semiconductors
Emulsions	Silicones
Esters	Soft drinks
Food	Sugar
Fructose	Vinegar
Glycols	Water
Glues	Well/spring water
Greases and oils	Wine

Properties of Filter Media

		Max. Operating Temperature	Operating Pressure	General Filtration Applications
Filter Bag Material	Rayon Viscous	250°F.	*	Solvents, petroleum products, organic acids and alcohols
	Polypropylene Agents	200°F	*	Strong acids & bases, salt solutions, oxidizing & reducing
	Nylon	300°F	*	Solvents, petroleum products
	Nomex	400°F	*	Solvents, weak acids and bases
	Wool	200°F	*	Animal & vegetable oils, petroleum products, solvents
	Polyester	300°F	*	Solvents, petroleum products, weak acids & bases
Vessel	Carbon Steel	650°F	150/300	Most chemicals except dilute acids and some salt solutions
	SS 304 & 316	450°F	150/300	Superior chemical resistance to above
"O" Ring	Buna N	250°F		Animal & vegetable oils, petroleum products
	Ethylene Propylene	300°F		Strong acids and bases; animal & vegetable oils
	Neoprene	300°F		Oils, fats, greases, salt solutions
	Silicone	500°F		Animal and vegetable oils, oxidizing chemicals
	Teflon™	550°F		All applications
	Thikol	160°F		Petroleum products, animal & vegetable oils, ethers
	Viton A™	400°F		Solvents, strong acids, animal & vegetable oils

How To Order

Before you order any filtration product from Strainrite, please call if you have any questions. The information required to "build a part number" is listed on each page of the Price Guide. The sample number below serves as a general guide for FELTS only. Mesh products as well as specialty filter bags require additional information. Keep in mind that each order number must have a minimum of five parts.

AP	10	P	2	S	HS	*
MATERIAL	MICRON	FINISH	SIZE	RING	OPTIONS	ASTERISK
This one or two letter code describes the material (fiber) used to construct the filtration product. Please see individual pages. FELTS: AP Polyester SP Polypropylene X Viscose N Nylon HT Nomex TE Teflon MESHES: PEMU Polyester Multi NMU Nylon Multi NMO Nylon Mono PEMO Polyester Mono POMO Polypro Mono	Please check individual material for micron availability. Need technical information to help with a decision regarding your needs, please call.	This letter indicates either the type of finish applied to the felt or the type of cover. Again, see individual page for ordering information. FELTS: P Plain (Standard) S Singed One Side B Singed Both Sides C Cerex Cover N Nylon Cover MESHES: P Plain (Standard)	This number indicates the filter bag size. Most bags fit into standard categories; however, special sizes are available. Please refer to the price list for all sizes. MOST COMMON: 1 7.0" x 16.0" 2 7.0" x 30.5" 3 4.08" x 8.0" 4 4.08" x 14.0" 30 4.118" x 10.0" 65 4.118" x 22.0" 612 5.5" x 13.0" 618 5.5" x 19.0" 630 5.5" x 31.0"	These letters describe the ring type to be used. Please read ring options on each page. All standards available. RINGS: S Carbon Steel SS Stainless Steel P Plastic Flange SR Seal Rite SR-2 Seal Rite (2sides) DS Draw String PO Polypropylene N No Ring	This item indicates a specific option choice - Handle, Multi-Column, Extended Life. Please check individual pages of Strainrite Price List for additional information or ask Customer Service.	This last item is added to a part number to indicate that there is additional information which MUST BE added to the order before it can be manufactured. As many orders require customization, the asterisk provides all of the additional specifications needed to fulfill an order.

MATERIAL/MICRON RATING	
	0.5 1 3 5 10 15 25 50 75 100 125 150 200
FELTS	Viscose X X X X X X X X
	Polypropylene X X X X X X X X X
	Polyester X X X X X X X X X X X X
	Nomex X X X X X X X X X

Other Materials and Microns available by special request

MONO- and MULTIFILAMENTS	
MESHES	Nylon monofilament (NMO) 5, 10, 25, 35, 50, 75, 100, 125, 150, 200, 250, 300, 400, 600, 800
	Polyester monofilament (PEMO) 5, 10, 25, 35, 50, 75, 100, 150, 200, 250, 300, 400, 600, 800
	Polypropylene monofilament (POMO) 30, 50, 100, 150, 200, 300, 400, 600, 800
	Polyester multifilament(PEMU) 100, 125, 150, 200, 250, 300, 400, 600, 800
	Nylon multifilament(NMU) 100, 125, 150, 200, 250, 300, 400, 600, 800

Hi-Pro Micro



Strainrite introduced the **Hi-Pro Micro** line of high performance filter bags several years ago and it has proved to be a very successful product. This line provides a full range of absolute rated filter bags to meet all your exacting needs. All three editions of the **Hi-Pro Micro (HPM)** line incorporate Strainrite's unique graduated layering of media - starting with a built-in pre-filter inner layer and progressing to the tighter outer layers. The smaller particles are systematically removed as fluid travels through multiple layers with each individual layer performing a special function. This graduation aids in the prevention of premature blinding which causes unnecessary filter change out.

The product line offerings include the **Hi-Pro Micro 9200**, the **Hi-Pro Micro 9500**, and the ultimate in bag filtration the **Hi-Pro Micro 9700**. An unrivaled product, Strainrite's **Hi-Pro Micro** line is the product suggested by US EPA for the most effective removal of giardia and other cysts. Strainrite's product has the lowest standard deviation of any other filter, which means users achieve more consistent results from batch to batch. Equally important, this product presents the ultimate value in high purity filtration.

The HPM-9700 "displayed the highest and most stable removal efficiency among the three bag filters examined . . . was selected for examinations under varied operational parameters . . ." U.S. EPA, Cincinnati, Ohio

Dirt Holding Capacity

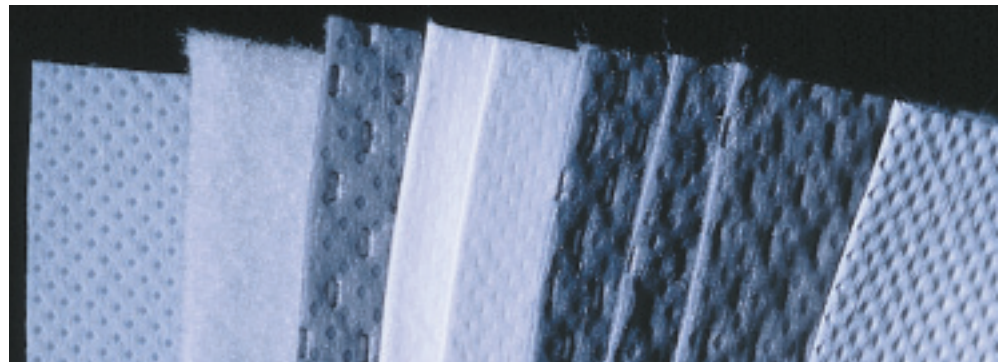
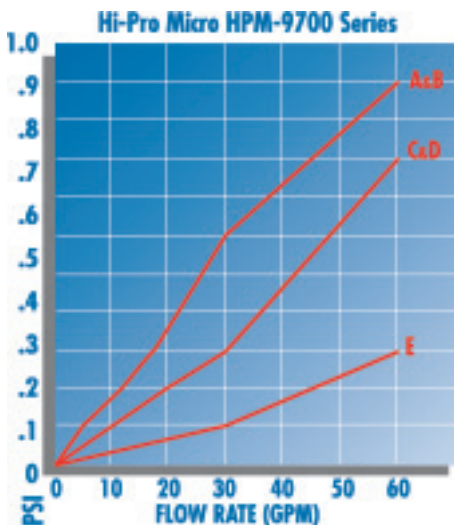

Unique Graduated Filter Design

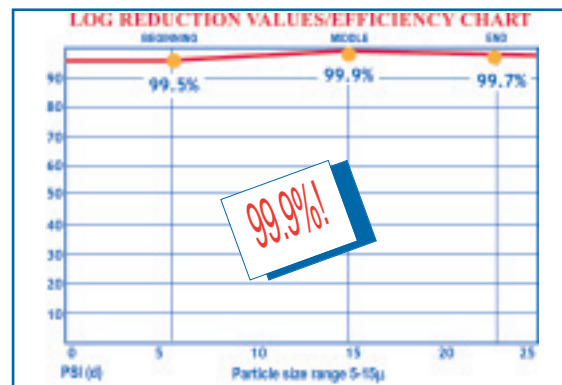

High Performance Filters



- Up to 97% Efficiency
- Superior dirt holding
- Best choice for oil contamination
- Effective removal of gel-like particles



- Particularly well suited for all applications requiring confident removal of specific particle sizes from liquids at a reasonable cost/benefit ratio.
- Up to 97% efficiency
- Superior dirt holding capacity

HIGH DIRT HOLDING CAPACITY

Although dirt holding capacity is relative to each application, flow rate, particulate load and particle size distribution, the **Hi-Pro Micro** line offers superior dirt holding capacity when compared to other high efficiency filter bags on the market.

Strainrite's factory testing of the unique patent pending design of pre-filter layers verifies that each succeeding layer of filter media is fully loaded with a given range of particulate. We recommend this filter to insure accurate results.

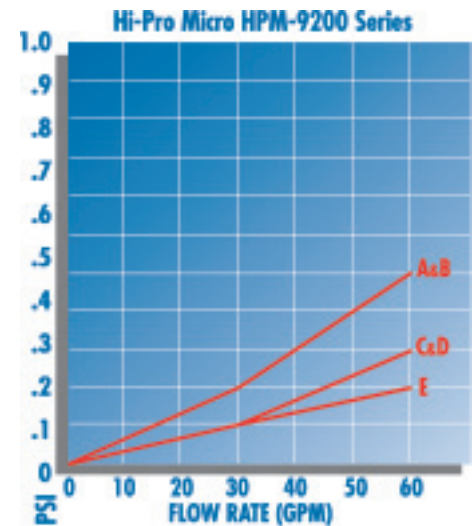
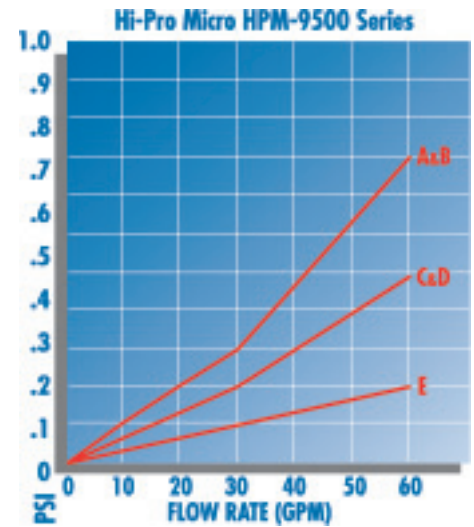

BEST RESULTS – CM HOUSINGS

To achieve the tested efficiencies for each product in the **Hi-Pro Micro** line, the use of Strainrite's **CM Style Housings** is required.



The Absorb-Rite® filter bag from Strainrite will remove oil or grease from aqueous based liquids. The Absorb-Rite® bag offers a unique two-in-one bag construction which separates functional layers of material, which allows maximum exposure time while keeping pressure drop across the material to a minimum. The specially engineered three layer construction includes an inner layer of polypropylene microfibers designed to hold 10-20 times their own weight (32 ounces) of oil and grease. The Absorb-Rite® bag offers up to 50% more absorbency than most competing brands!

Features:

- Unique three layer construction results in maximum exposure time at minimum flow rate
- The top disc pre-filter material removes dirt and other particulate material prior to the adsorption of hydrocarbons
- Designs available to remove particles in the 1-100 micron range
- Absorb-Rite® has higher hydrocarbon removal capacity than other filter bags on the market
- Has higher capacity than most other bags on the market
- Standard bags fit #1 and #2 size filter vessels (fit competitor housings as well)
- Designed to minimize contamination during changeover

Applications:

- Electroplating Paints
- Liquid Fertilizers
- Electroplating
- Pickling liquids
- Cutting Oil Removal
- Waste Water Treatment
- Available to fit all Bag Filter Housings

Anywhere oil or grease must be separated and removed from an industrial stream, Absorb-Rite® bags are designed to fill the need.

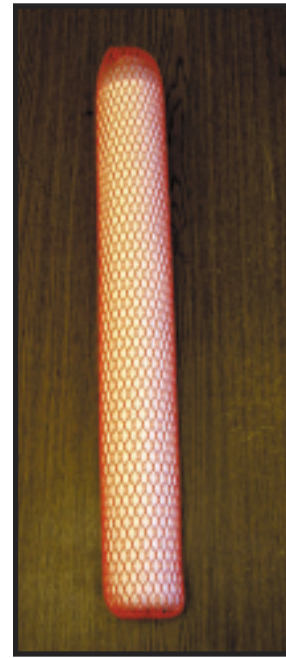

Our oil absorption logs are made from melt blown spun bonded polypropylene micro fiber felt media that is rolled around a polypropylene mesh core and then surrounded with a heavy polypropylene mesh cover.

These logs are simply placed inside whatever filter bag you choose, be it of a felt or woven constructions. This unique design enhances the media's ability to "wick" the free oil and grease out of your contaminated liquid. Also, the only delta p restrictions you have is based on that of the filter bag itself as the flow of liquid passes around the oil log.

Mag Bag

Carbon & Chemical Ready

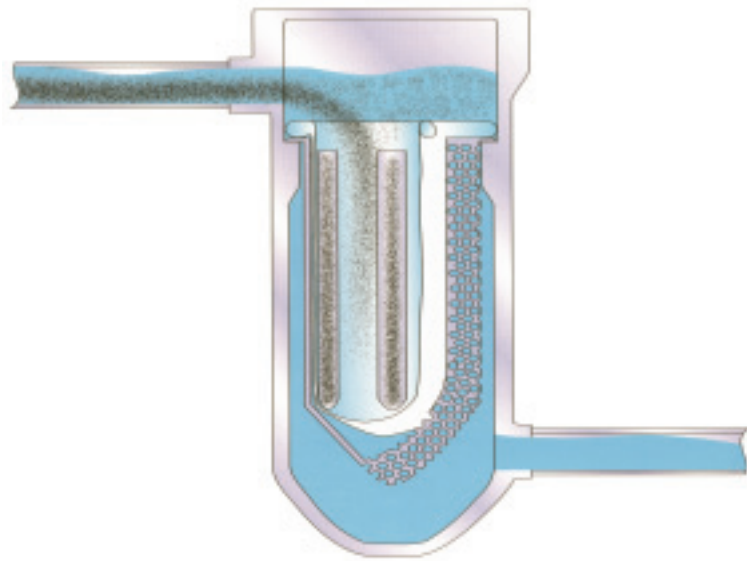

The MAG BAG comes in a range of sizes and materials for virtually any liquid application. It is designed to attract microscopic ferrous impurities.

- Minimizes downtime & waste-water treatment costs
- Keeps spray nozzles clean
- Multi-magnet design for tramp metal removal
- Extends life of cutting tools, equipment and metal-working liquids

USE IN

- Plating
- Painting
- Parts Washing
- Food Processing
- Pre-cleaning process water
- Cutting, grinding & boring
- Coolants or lubricants

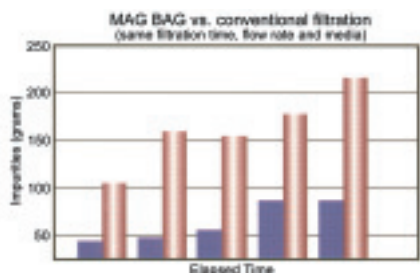

Easy to use

This Strainrite innovative bag is all set up to add carbon, resin, clays or chemicals to filter through. It is designed with an inside impervious side wall forcing the liquid to pass through the entire column.

- The contamination is conveniently trapped in an easy to dispose bag.
- The clean effluent passes through the bottom and back into your system.
- The top features a zippered disc so filling is easy.

Call your sales person today for more technical support.

Aqua-Rite Potable



Strainrite Inc. has developed the "Aqua-Rite" Potable Water Filtration System to meet the requirements of the Surface Water Treatment Rule and the regulatory protocols of most states. "Aqua-Rite" is appropriate technology for surface water sources, as well as ground water under the influence.

This system features a dual-stage design that initially removes debris and larger contaminants, before filtering out disease producing microorganisms. This approach extends the life of the element that filters out the Giardia and Cryptosporidium cysts.

"Aqua-Rite" is constructed entirely of ANSI/NSF Standard 61 approved materials and components, using high-grade stainless steel for the filter housings, and virgin polypropylene microfibers for the filter elements. Each component has undergone rigorous toxicological testing by Underwriter's Laboratories, in accordance with NSF protocol.

The system consists of a prefilter and a final filter stage, utilizing filter housings specifically engineered for this critical application. These vessels employ a proven, proprietary "5 points of seal" design, effectively eliminating by-pass.

The prefilter element is the SWT1-P2S-8T, featuring our patented graded density "Valu-Life" design. This unique filter offers interior columns that facilitate higher efficiencies and longer life, even in heavy contaminant load applications.

The final filter/bacterial barrier elements are part of the acclaimed "Hi-Pro Micro" Filter Series. Our unique graduated filter design results in superior efficiencies, is especially well suited for removing malleable particles such as microorganisms, and typically results in a combination of longer life and cost efficiency that eclipses competing filters. The HPM97-GC-A-2SS gives reliable 2 log removal in the 5-15 micron [Giardia] range. The HPM97-CC-A-2SS provides the added protection of reliable 2 log removal in the 2-5 micron [Cryptosporidium] range.

All components comprising the "Aqua-Rite" System are constructed to exacting standards in our new, state of the art, silicone-free manufacturing facility located in Auburn, ME.



Typical Sites/Applications

- Municipal Facilities
- Seasonal Resorts
- Campgrounds
- Island Communities
- Industrial Plants
- Schools
- Remote Locations
- Food and Beverage
- F.D.A. Compliant applications

The advantages of "Aqua-Rite"

- Low capital cost
- Low residual cost
- Low maintenance
- Low Tech / Operator friendly
- Compact
- Modular design
- Easily expandable
- Adaptable footprint
- Fixed or Portable systems

Drinking Water Filtration

• These specially engineered products are used in applications where high efficiency filtration and Certified **NSF Standard 61** compliance are required, most notably for potable water (to achieve compliance with the Surface Water Treatment Rule), and in the food and beverage industry. This product line is serviced and sold only through specially trained and selected distributors. Please consult the factory at Extension 203 for the distributor in your area.

AQ 2-2 High Efficiency Filter Vessels - for use with #2 Size HPM Series Filter Bags

- Proprietary “5 Points of Seal” Design
- Constructed entirely of **NSF Standard 61** Certified materials
- 304 Stainless Steel (Body, Stand, Internals)
- Integral Compression Device
- 2” NPT Side Inlet / Bottom Outlet
- Swing-Bolt Closures
- Premium Stainless Steel Wire Mesh Support Basket - enhances filter life
- Adjustable Tripod Stand
- Differential Gauge Ports w/ Mounting Bracket
- 1” Drain Port, 1/4” Blown-Down Port in Lid
- Rated for 150 psi Continuous Service
- Hydrotested to 225 psi



AQ2-2BSHD (single cavity vessel NPT)

AQ2-2FBSHD (single cavity vessel flanged)

HPM Series Potable Water / Food & Beverage Processing Filter Bags

- Potable water applications require The Strainrite Companies AQ Series Vessels.
- Food processing Applications may use either AQ or CM Series Vessels.
- **NSF Standard 61** Certified
- Packaged 8 filters per case.

HPM97-GC-2SS

(for Giardia-sized particle removal)

HPM97-CC-2SS

(for Cryptosporidium-sized particle removal)



SWT1-P2S-8T Prefilter Bags

- Highly effective / High Dirt Load Capacity
- Fabricated entirely from FDA / **NSF Standard 61** compliant materials
- Recommended as HPM series prefilter - Packaged 8 filters per case



Valu-Life (Column) Bag

The **Valu-Life (Column) Bag**, our most recently patented filtration product, has four times more effective filtration surface than a standard single layer filter bag. (US PATENT #5,549,826,) With greater surface area and increased depth this filter provides both longer life and higher efficiency.

Designed specifically for those clients who are interested in reducing cost as well as minimizing waste, Valu-Life's unique multiple "column" construction achieves on average 4-6 times longer life on average over a conventional single-layer filter bag.

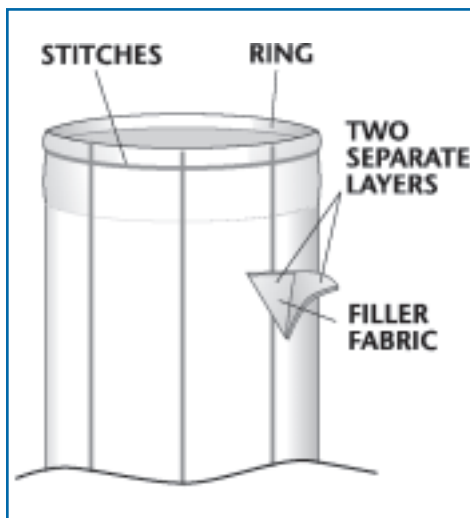

AREAS OF COST SAVINGS:

- Fewer change-outs
- Reduced process flow downtime
- Increased productivity
- Less product loss
- Reduced disposal costs

The Valu-Life (Column) Filter Bag is available in both felt and mesh medias ranging from 1 micron to 800 micron. It can be manufactured in a variety of designs to fit any industry standard filter vessels.

CUSTOMER COMMENTS:

"Valu-Life Bag is two-thirds the cost of our previous bag - and it lasted three times longer."

"Valu-Life Bag gave us less change-out, longer life and reduced filter cost from \$85,000 to \$41,000 per year."

Results from Field Case Studies

Liquid Filtered	Conventional Filter Bag Micron	Life of Bag	Valu-Life Bag Micron	Life of Valu-Life	Extended Bag Life Ratio
Base for perfume	5	133 gallons	5	400 gallons	3:1
Black soy-based printing inks	25	12 mins. at 20 PSID	25	60 mins. at 12 PSID	5:1
Ground water	25	1200/gallons	25	2400/gallons	2:1
Film reprocessing	5	700/gallons	5	9500/gallons	12:1
Ground water	50	100/gallons	50	900/gallons	9:1
Base for Paint	25	1.5 mins./25 PSID	25	7.5 mins/20 PSID	5:1
Ground water	25	100/gallons	25	500/gallons	5:1
Methanol	3M 114C	3000/gallons	1	9000/gallons	3:1
Resin	25	300/gallons	25	5000/gallons	16:1

String Wound Cartridges



The Strainrite Companies offer quality wound cartridges which allow us to be your one stop buying solution to all your filtration needs.

Our wound cartridges are available in a complete line of filter media, such as natural and bleached cotton, rayon, polypropylene and fibrillated polypropylene, etc., and core material, such as polypropylene, tinned steel, 304 stainless steel, 316 stainless steel, and phenolic. Our standard sizes are 10", 20", 30", 40" and variations of the standard lengths and outer diameters to meet your needs. We offer 12 different micron ratings, thus allowing the best possible combination for your particular application.

STRINGWOUND CARTRIDGES

Style		Media		Micron		Diameter		Length		Center Core		End Caps		Core Cover	
SW	Stringwound	C	Bleached Cotton	*25	0.25	A	1.5"	3	3"	G	Fiber Glass	-	No Treatment	-	No Core
		CC	FDA Bleached	*5	0.5	B	1.75"	4	4"	P	Polypropylene	10	Acetone		Cover
		CN	Unbleached Cotton	1	1	C	2.25"	9*75	9.75"	PG	Glass Filled	11	Crimped Core	M	Membrane
		G	Fiber Glass	3	3	D	2.375"	10	10"		Polypropylene	13	EPR Gasket	S	Sock
		N	Nylon	5	5	E	2.5"	19*5	19.5"	S	304SS	15	Lacquer	V	Non-Woven
		P	Polypropylene	10	10	F	2.625"	20	20"	S1	316SS	16	Metal Core		Polyester
		PE	Polyester	20	20	G	2.6875"	29	29"	TS	Tinned Steel		Extender	W	Paper
		PF	Polypropylene	30	30	H	2.75"	30	30"			18	Polypropylene	Y	Polypropylene
			Fibrillated	50	50	I	3"	39	39"				Core Extender		
		PP	FDA Polypropylene	75	75	J	3.125"	40	40"			21	Singed Ends		
		PX	Xtrupor	100	100	K	3.5"	50	50"						
		XR	Non-FDA Rayon	200	200	M	4"								
						N	4.5"								
				Q	6"										

Resin Bonded Cartridges



The Strainrite Companies utilize and sell a variety of three different style resin bonded cartridges to handle a wide range of applications from petroleum to high viscosity resin, coatings and adhesives. Each style has a one-piece construction (up to 40 inch length) eliminating the possibility of breakage or bypass at the joints.

Two of our phenolic resin styles utilize a unique spiral wrap design to maximize particle removal and service life in viscous fluid filtration applications. An outer spiral prefilter wrap increases the surface area thus increasing the life of the filter, while the inner layers control particle removal at rated size.

Our third style utilizes a resin-bonded fiber glass filter cartridge. The unique grooved construction increases surface area for longer life, and higher dirt-holding capacity.

To determine which style best meets your application, please call one of our Strainrite Companies professionals to help solve your filtration needs.

RESIN BONDED CARTRIDGES

Grade		Micron		Diameter		Length		Center Core		End Caps		O-Rings		Cover	
RB	Resin Bonded	1	1	E	2.5"	4*75	4.75"	-	Coreless	-	None	-	None	-	No Cover
		3	3			9*5	9.5"	HP	Heavy	5	222/Single Open	B	Buna-N	C	Cotton
		5	5			9*75	9.75"		Polypropylene	6	226/Single Open	D	EPDM	P	Polypropylene
		10	10			10	10"	HT	Heavy Tin-	8	222/Spear	E	EPR		
		15	15			12	12"		Coated Steel	9	226/Spear	H	HDPE		
		20	20			19*5	19.5"	P	Polypropylene	12	Double Open	S	Silicone		
		30	30			20	20"			14	Foam	T	Teflon		
		40	40			29*25	29.25"			17	Poly Spear	TS	Teflon/Silicon		
		50	50			30	30"			19	PolySpring/222	TV	Teflon/Viton		
		70	70			39	39"					V	Viton		
		75	75			40	40"								
		90	90												
		100	100												

Meltblown Cartridges



We offer a unique variety of high quality, high efficiency and absolute rated polypropylene and nylon meltblown cartridges. Our spectrum of quality patented cartridges allow us to provide the best value in the industry. Consistent filtration performance, longer life cycles, fewer change outs reduce labor cost.

Our meltblowns have a true graded pore structure which enhances increased dirt holding capacity. Our cartridges are free of surfactants, binders and adhesives. We are happy to help you select the best cartridge for your application.

MELTBLOWN CARTRIDGES

Style		Efficiency		Media		Micron		Outside Diameter		Length		Core	
MB	Meltblown	A	Absolute	N	Meltblown Nylon	*5	0.5	E	2.5"	4	4"	N	Nylon
		G	Grooved	P	Polypropylene	1	1	N	4.5"	5	5"	P	Polypropylene
		N	Nominal			3	3			9*75	9.75"		
						5	5			9*875	9.875"		
						10	10			10	10"		
						15	15			19*5	19.5"		
						20	20			20	20"		
						30	30			29*25	29.25"		
						40	40			30	30"		
						50	50			39	39"		
						70	70			39*5	39.5"		
						90	90			40	40"		
						120	120						
						150	150						
				200	200								

Pleated Cartridges

INDUSTRIAL GRADE PLEATED CARTRIDGES

Grade		Media		Micron		Diameter		Length		End Cap		O-Ring			
PI	Industrial	CD	Cellulose Depth	*5	0.5	E	2.5"	9*75	9.75"	5	2-222/Closed Cap	-	None		
		GD	Fiber Glass Depth	2	2	I	3.0"	10	10"	12	Double open End	B	Buna-N		
		RD	Polyester Depth	5	5	L	3.75"	19*5	19.5"	22	Special	D	EPDM		
		PD	Polypropylene Depth			10	10	N	4.5"	20	20"	23	Spring	E	EPR
						20	20	O	4.9375"	29*25	29.25"			H	HDPE
						40	40	R	6.25"	30	30"			S	Silicone
						70	70	S	7.0"	36	36"			T	Teflon
								T	7.75"	40	40"		TS	Teflon/Silicone	
										X	Custom		TV	Teflon/Viton	
													V	Viton	

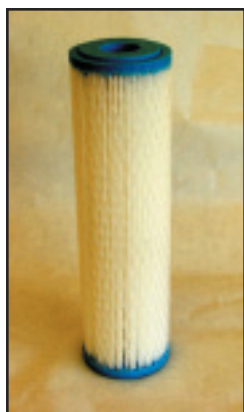

The Strainrite Companies offer industrial pleated cartridges as a cost savings option to stringwound and meltblown due to the pleats that provide increased surface area and longer life.

The spectrum of pleated cartridges range from a nominal rated PP and PE media used for water processes, to patented absolute rated Beta 5000 ratio cartridges for amine and glycol processes.

Please consult one of our Strainrite Companies sales professionals to help you find the best filter for your application.



The **STRAINRITE** Companies

World Class Filtration

The Strainrite Companies
PO Box 1970
65 First Flight Drive
Auburn, Maine 04210

207-376-1600
FAX 207-777-3177

Web site: www.strainrite.com
Email: info@strainrite.com



12410 Clark Avenue
Santa Fe Springs, California
90670

562-941-1203
FAX 562-941-1202

Distribution & Warehousing



Industrial Filtration Specialists
65 First Flight Drive
Auburn, Maine
04210

207-376-1600
FAX 207-777-3177

**Headquarters and
Manufacturing Facility**



481 N. Saginaw
Pontiac, Michigan
48342

248-334-2160
FAX 248-334-2788

Manufacturing Facility