

INSTRUCTION MANUAL

TLV SNIFFER[®]

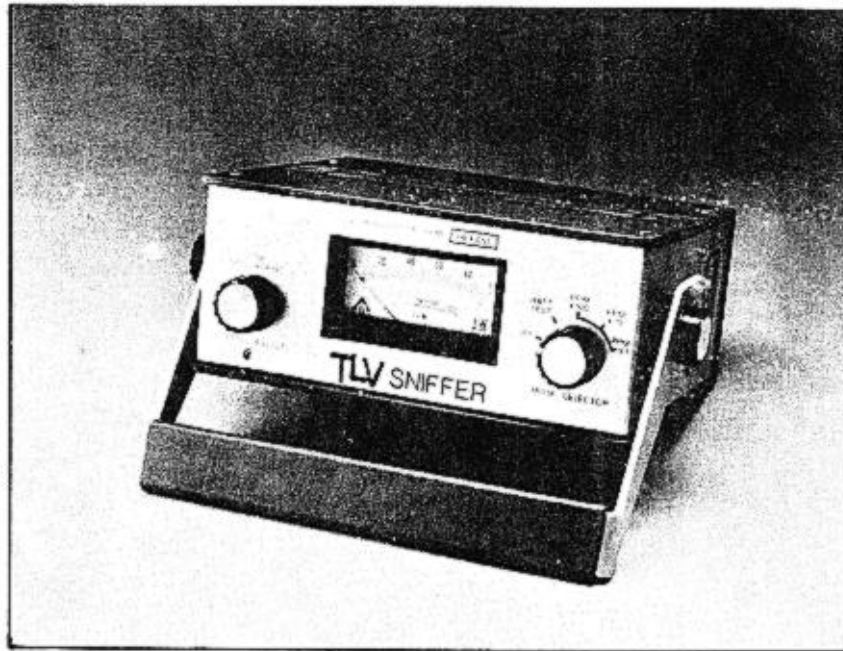

WARNING!

Because this instrument is used to detect and monitor materials and conditions which are listed by OSHA or others as potentially hazardous to personnel and property, the information in this manual must be fully understood and utilized to ensure that the instrument is operating properly and is both used and maintained in the proper manner by qualified personnel. An instrument that is not properly calibrated, operated and maintained by qualified personnel is likely to provide erroneous information, which could prevent user awareness of a potentially hazardous situation for the instrument user, other personnel and property.

If, after reading the information in this manual, the user has questions regarding the operation, application or maintenance of the instrument, supervisory or training assistance should be obtained before use. Factory assistance is available by calling (412) 963-2000.

Bacharach, Inc.

625 Alpha Drive, Pittsburgh, PA 15238 (412) 963-2000

WARRANTY

Bacharach, Inc., warrants to Buyer that at the time of delivery this Product will be free from defects in material and manufacture and will conform substantially to Bacharach Inc.'s applicable specifications. Bacharach's liability and Buyer's remedy under this warranty are limited to the repair or replacement, at Bacharach's option, of this Product or parts thereof returned to Seller at the factory of manufacture and shown to Bacharach Inc.'s reasonable satisfaction to have been defective; provided that written notice of the defect shall have been given by Buyer to Bacharach Inc. within one (1) year after the date of delivery of this Product by Bacharach, Inc.

Bacharach, Inc. warrants to Buyer that it will convey good title to this Product. Bacharach's liability and Buyer's remedy under this warranty of title are limited to the removal of any title defects or, at the election of Bacharach, to the replacement of this Product or parts thereof that are defective in title.

The warranty set forth in paragraph 1 does not apply to parts the Operating Instructions designate as having a limited shelf-life or as being expended in normal use.

THE FOREGOING WARRANTIES ARE EXCLUSIVE AND ARE GIVEN AND ACCEPTED IN LIEU OF (i) ANY AND ALL OTHER WARRANTIES, EXPRESS OR IMPLIED, INCLUDING WITHOUT LIMITATION THE IMPLIED WARRANTIES OF MERCHANTABILITY AND FITNESS FOR A PARTICULAR PURPOSE: AND (ii) ANY OBLIGATION, LIABILITY, RIGHT, CLAIM OR REMEDY IN CONTRACT OR TORT, WHETHER OR NOT ARISING FROM BACHARACH'S NEGLIGENCE, ACTUAL OR IMPLIED. The remedies of the Buyer shall be limited to those provided herein to the exclusion of any and all other remedies including, without limitation incidental or consequential damages. No agreement varying or extending the foregoing warranties, remedies or this limitation will be binding upon Bacharach, Inc. unless in writing, signed by a duly authorized officer of Bacharach.

NOTE: Fuses, batteries and sensors are expendable items not covered by the warranty.

NOTICE

This manual contains proprietary information that shall not be reproduced or copied in whole or in part as the basis for manufacture of items herein described.

Instruction 23-9613
TLV Sniffer®
Rev. No. 2
January, 1990

USE OF DILUTION PROBE 23-7355 WITH TLV SNIFFER

Dilution probe 23-7355 has an O-ring covering holes designed to admit fresh air to dilute, by a factor of 10, any gas sample passing through the probe. With the O-ring moved to expose the dilution holes, the 10:1 dilution ratio enables the TLV Sniffer to indicate concentrations up to 100,000 ppm, thus accommodating sample concentrations above the normal 10,000 ppm limit of the Sniffer.

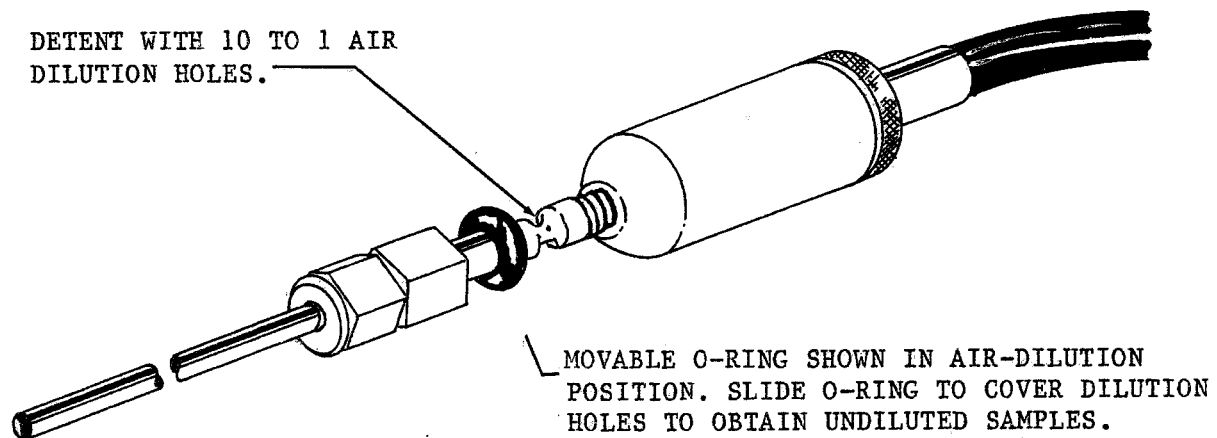

It must be remembered that, when using this probe in the dilution mode, all meter indications should be considered as approximate, only. This is true because of several variable factors which can affect the probe operation, such as:

1. The actual dilution ratio is dependent upon the flow rate of the sample. The flow rate is affected by battery charge, speed of the pump, cleanliness of the probe, condition of the probe filter, etc.
2. The actual dilution ratio is dependent upon the quality of the air which provides the dilution. If the dilution holes are ingesting combustible gases rather than fresh air, the ppm indication of the Sniffer will vary significantly from that of an indication obtained with fresh air entering the dilution holes.

WARNING: At the extreme, of course, if the dilution holes and the probe tip are sampling from the same atmosphere, no dilution actually occurs. In that instance, if perfect dilution is assumed when interpreting meter indications, an error of 1000% is incurred.

REMEMBER:

- For proper dilution, only fresh air should enter the dilution holes.
- Multiply all meter indications by a factor of 10 when using the probe in the dilution mode.
- All meter readings in the dilution mode should be considered as approximate, only.
- Don't forget to re-cover the dilution holes with the movable O-ring to obtain undiluted gas samples.

Bacharach, Inc.

625 Alpha Drive, Pittsburgh, PA 15238 (412) 963-2000

TECH NOTE

9

NICKEL-CADMIUM BATTERY MAINTENANCE

DO:

1. Recharge new NiCads before use. It is a good idea to cycle them once or twice before normal operation. This requires three steps: (1) fully charging the NiCads, (2) discharging until the unit ceases functioning or indicates low battery power, and (3) fully recharging (12-16 hours).
2. Put NiCads through a charge cycle at least once a month when they are not in use. NiCads function best when they function frequently.
3. Prevent "memory" from occurring by running the NiCads through a full discharge/charge cycle every week or two (once a month at least).
4. Match charge time to use on about a two to one ratio (e.g., if you use the NiCads for four hours, charge them for about eight hours).

DON'T:

1. Do not use new NiCads without putting them through a full charge.
2. Do not attempt to use NiCads (or leave the instrument "ON") when the cells are fully discharged. To obtain proper instrument operation, and to prevent NiCad damage, the cells must be recharged before further use.
3. Do not overcharge:
 - a. Never leave NiCads charging for more than 16 hours.
 - b. Do not charge over an entire weekend.
4. Do not attempt to charge other types of batteries in a NiCad charger or to charge NiCads in a charger other than one designed specifically for NiCads.

Issue Date: October 1981
P/N 51-9480

BACHARACH

EXPLANATION:

The Nickel-Cadmium battery (NiCad) can best be thought of as an energy reservoir. Provided that it is properly filled with energy, it will supply that energy at a useful rate for many applications. However, underfilling or overfilling the reservoir can cause serious problems, including the destruction of the system. It is the purpose of this bulletin to explain how NiCads should be maintained to insure that they will last for the hundreds and even thousands of energy transfers for which they are designed.

Most of the NiCads used in portable instruments are designed to carry an energy supply sufficient to power the instrument for about 6-8 hours. Because of electrical and chemical losses, more energy must be put into the NiCads than is drawn from them as they discharge while being used. Therefore, it normally takes from 12-16 hours of charging time to refill depleted NiCads completely. If you use an instrument for 6-8 hours a day and then charge it each night for 12-16 hours, you should obtain hundreds of cycles of NiCad use. However, if you use an instrument for varying periods of time each day, or if you use it only occasionally, then the charging requirements become more complex.

Due to some peculiar characteristics of NiCads, the manner in which they are charged is crucial in determining how well and how long they will function. There are several things that can go wrong with NiCads, and it is important to know what they are:

1. If NiCads are used when they are almost totally out of energy, they can be destroyed. This happens because the internal ionic structure of one of the NiCad cells reverses polarity. Consequently, do not continue to use an instrument with NiCads when the battery monitoring system indicates low or depleted batteries. The instrument should be turned off and recharged before being used again.
2. If NiCads are overcharged, they can be destroyed. NiCads work by means of an internal chemical-electrical process, involving interaction of gases and metals. When NiCads are charged, gases are built up in the cells. If overcharging occurs, the gas pressure in the cell can become too high, causing internal damage in the cell and the possibility of an explosion. None of Bacharach's NiCad systems should be left in a charging condition for more than 16 hours, and, in general, 12-14 hours of charging should be sufficient. Do not leave an instrument charging for an entire weekend, as it will almost certainly cause overcharging, a reduction of the NiCad life, and even a safety hazard. Also, the charge time required to refill the NiCad reservoir is related to how far discharged the NiCad is. Thus, if you have a NiCad system designed to power an instrument for eight hours, and you use it for only two hours, you do not need to recharge it for a full 12-14 hour period. Instead, 3-4 hours of charging should be sufficient to return the unit to a full charge.
3. NiCads lose energy when not in use. NiCads have a shorter shelf life than other kinds of batteries. They will lose 25% of their charge in one month of non-use, 50% in three months, and 85% in five months. This means two things: (1) you should apply a full charge to the NiCads supplied with a new instrument before you use the instrument for the first time, and (2) if an instrument remains idle for one month or more, it should be charged before use.

4. NiCads tend to develop a "memory." For example, if a set of Nicads is used for three hours every day and then recharged, the internal ionic structure will eventually tend to "memorize" that cycle and the NiCads will readily yield only three hours of service. Once this "memory" occurs, no amount of recharging will overcome it. It will be necessary to discharge the batteries almost completely (which may take considerably longer than normal) and then to recharge them in order to defeat the "memorized" ionic structure. Sometimes this cycle (depletion/recharge) will have to be repeated two or three times before the "memory" can be overcome.

The best way to insure against "memory" is to fully cycle the NiCads periodically. That is, once every week or two, leave the instrument on until the battery indication shows a low reading or a recharge requirement (be careful not to leave the unit on for too long), and then charge the unit fully overnight (12-16 hours). This will revitalize the entire internal ionic structure of the NiCads and will prevent "memory" from occurring.

CONTENTS

	<u>PAGE</u>
<u>SECTION 1</u>	1-1
DESCRIPTION	
PURPOSE AND FUNCTIONS.	1-1
Toxicity Warning Function	1-1
PPM Meter	1-1
Search Function	1-1
Continuous Self-Monitoring.	1-1
PRINCIPLE OF OPERATION	1-1
SENSITIVITY RANGES	1-2
ACCURACY AND RELIABILITY	1-2
PHYSICAL DESCRIPTION	1-3
Instrument and Case	1-3
Air Sampling Mechanisms	1-3
Combustible Gas Detector.	1-4
AUXILIARY EQUIPMENT.	1-4
Probe and Hose.	1-4
Earphone.	1-4
Batteries	1-4
Battery Charger	1-5
Recorder.	1-5
CONTROLS	1-5
Mode Selector	1-5
ADJUSTMENTS.	1-5
Meter Zero Mechanical Adjustment Screw.	1-5
Meter Zero Coarse Adjustment Screw.	1-6
Meter Zero Fine Adjustment Knob	1-6
Gain Potentiometer Adjustment Screws.	1-6
Alarm Level Potentiometer Adjustment Screw.	1-6
Recorder Level Potentiometer Adjustment Screw	1-6
 <u>SECTION 2</u>	 2-1
PRE-OPERATION CALIBRATIONS AND ADJUSTMENTS	
BATTERY TEST	2-1
SETTING METER POINTER TO ZERO.	2-1
SETTING METER POINTER DEFLECTION (GAIN CALIBRATION).	2-2-5
RESETTING ALARM RESPONSE	2-6
SETTING RECORDING LEVEL.	2-7
 <u>SECTION 3</u>	 3-1
OPERATION	
MONITORING TOXICITY.	3-1
Direct Readings and Alarm	3-1
Converting Hexane-calibrated Meter ppm Readings to ppm	
Readings for Other Gases.	3-1
Converting ppm Readings to Percent Lower Explosive Limit.	3-3
LOCATING GAS LEAK SOURCES.	3-4

	<u>PAGE</u>
<u>SECTION 4</u>	4-1
MAINTENANCE AND REPAIRS	
SYMPTOMS AND REMEDIES (TABLE)	4-1
REPLACING FAULTY COMPONENTS AND PARTS.	4-5
Replacing Batteries	4-5
Replacing Detector.	4-5
Replacing Printed Circuit Board	4-5
Replacing Sample Pump	4-6
 <u>SECTION 5</u>	 5-1
REPLACEMENT PARTS LIST	5-1

ILLUSTRATIONS

FIGURE

1-1	TLV Circuitry Adjustment Potentiometer Locations.	1-7
2-1	Bacharach Code 51-7199 Gas Calibration Kit.	2-3
2-2	Calibration Gas Transfer Assembly	2-3
2-3	Locating and adjusting R-13 on PPM X 100 Position	2-5
2-4	Locating and adjusting R-3 for Certified Gas Indication	2-6
3-1	Use of Dilution Probe and Hose Assembly and I In-line Filter and Trap Assembly.	3-2
3-2	Conversion Curves Showing Relationship of PPM Concentrations of Various Gases to Percent L.E.L. Equivalents.	3-4
4-1	TLV Sniffer Chassis Subassembly Showing Miniature Pump Assembly in Disassembled Position.	4-7

TABLES

TABLE

3-1	Multiplying Factors for Converting PPM Meter Readings of Hexane-calibrated Instruments to PPM Concentrations of Other Gases	3-3
4-1	Troubleshooting Procedures.	4-1

SECTION 1

DESCRIPTION

PURPOSE AND FUNCTIONS

Toxicity Warning Function

The portable TLV Sniffer is an extremely sensitive combustible gas and vapor sensing instrument with an overall detecting sensitivity range of from 1 to 10,000 parts of gas or volatile flammable vapor per million parts of air (by volume). The instrument is equipped with an audible (beep) alarm that can be set to sound at any desired level of gas concentration to warn automatically of toxic concentrations of gas. Connections are provided for an auxiliary earphone for use in noisy areas to assure that audible warnings will be heard.

PPM Meter

A meter reading directly in parts per million (ppm) allows instant visual determination of toxicity danger as readings are compared to published standard Threshold Limit Values. The instrument can be calibrated to read directly in parts per million for any one of many kinds of combustible gases. Factory calibration is for hexane unless otherwise specified, though readings from other gases and vapors may be interpreted easily by means of reading conversion curves (in OPERATION Section, this manual).

Search Function

In addition to its primary function of indicating ppm combustible vapor concentrations and toxicity levels, an ultrasensitive "search" range of from 1 to 100 ppm makes the TLV Sniffer especially useful for locating hard-to-find gas leaks. A hand-held probe attached to the instrument can be moved in the direction indicated by rising meter readings to point out quickly the source of escaping gas.

Continuous Self-Monitoring

Other functions provided in the TLV Sniffer circuitry for continuous self-monitoring purposes include a continuous, audible note of warning in response to failing batteries and to excessive negative drift in signal voltage due to malfunctioning detector circuit components. A 45-second time delay circuit is incorporated to prevent the sounding of a false alarm due to temporary voltage imbalances during the brief warmup period after the instrument mode selector switch has been set to operate the instrument.

PRINCIPLE OF OPERATION

To detect and measure concentrations of combustible gas in the air, the TLV Sniffer catalytically oxidizes gas in a pumped-in sample of air by means of a catalyst-coated resistance element. The resistance of this element changes with changes in heat that are proportional to the amount of oxidized gas, thereby altering the electrical balance of the catalytic element as

compared to the resistance of a reference element. Both the catalyst-coated ("active") element and the reference element are incorporated in a Wheatstone Bridge circuit in such a way as to produce an electrical output proportional to their differences in resistance. Since any changes in air sample temperature and humidity affect both active and reference elements equally, the electrical signal output is proportional to the concentrations of combustible gas or vapor in the sample of air (expressed in volumetric terms as ppm). However, sudden changes in humidity may affect the zero reading on the X-1 range. The instrument should, therefore, be zeroed at the same R.H. prevailing during use.

The audible alarm response at the desired gas concentration ppm level is accomplished by comparing the gas concentration signal level with an internal reference voltage. Amplification of the difference between signal and reference voltages will, at a preset level, operate the audible alarm.

SENSITIVITY RANGES

The TLV Sniffer circuitry and meter provide readings from 0 - 10,000 ppm in three range settings. The first, with MODE SELECTOR switch set at PPM X 100, indicates from 0 to 10,000 ppm on the meter. The second range, with MODE SELECTOR set at PPM X 10, gives readings between 0 to 1000 ppm. The third range setting, at MODE SELECTOR position PPM X 1, provides readings from 0 to 100 ppm. Each range setting requires an easily made adjustment of the ZERO ADJUST control knob on the instrument front panel to set the meter indicating pointer to zero. Span adjustments for full-scale pointer deflection within each range are made periodically as necessary by means of three gain potentiometers located within the instrument.

ACCURACY AND RELIABILITY

The extent to which meter readings correspond to actual parts per million of combustible gases in sampled air depend upon (1) the internal electrical stability of the instrument, (2) proper calibration of the instrument on gas mixtures of known concentration, and (3) purity of the air sample used for meter pointer zero setting.

The electrical stability of TLV Sniffer circuitry is best demonstrated with the MODE SELECTOR switch set at PPM X 1. In this most sensitive range of the instrument, all gas signal voltages are multiplied by 100, so that a 0- to 1-millivolt signal actually drives the meter pointer with the necessary 0 to 100 millivolts to achieve full-scale deflection. Thus a pointer deflection of 1/100 sensitivity of the TLV circuitry to minute electrical changes, the meter needle shows practically no deflection as power is applied to the speaker for the audible beep signal.

Given this electrical stability, any lack of correspondence between actual parts per million of combustible gas and the meter readings would be much more likely to arise from improper calibration of the instrument, or from setting meter zero in the presence of impure air than from instability of the TLV Sniffer circuitry.

Calibrated for hexane gas (a relatively high-energy gas) at the factory, the TLV Sniffer should also provide accurate ppm readings for benzene, toluene, and other gases of similar combustion rates. Conversion curves aid in correctly interpreting readings from combustible gases that release energy at different rates.

Thus, purity of the air sample used for meter pointer zero settings is by far the most important factor in obtaining accurate ppm readings. Ideally, the pointer should be zeroed in the PPM X 1 mode of operation, where deviations from zero would be more apparent because of maximum deflection. In this range, however, extreme sensitivity causes the instrument to respond to the slightest traces of gas. Wisps of cigarette smoke, fumes from passing autos, and subtle air contaminations from many other sources may affect the zero setting. The extent to which zero readings are biased because of air sample impurities will be reflected in less accurate readings of actual gas concentration ppm. Frequently, an apparent negative drift of the meter pointer may be caused by carrying the instrument to an area of fresher air after zeroing the meter inadvertently on air that was not as pure.

PHYSICAL DESCRIPTION

Instrument and Case

The TLV Sniffer is housed in a sturdy, brushed-aluminum and blue, wrinkle-finished plastic case. An attractively designed carrying handle serves also as an adjustable support stand and shoulder strap holder. Weighing 5-1/2 lbs., the compact 8-x6-1/2-x3-1/4-inch instrument is as convenient to carry as a transistor radio. A front panel, easily visible with the instrument in carrying position, contains a meter reading directly in ppm, and control knob for range selection and zero setting of the indicating meter pointer. The side panels of the instrument provide plugs and connectors for an air sample probe, earphones, battery charger, and recorder. Removal of ten screws holding the rugged plastic cover to the rigid aluminum case gives access to batteries and calibration adjustment controls located within the interior of the case.

TLV Sniffer Models

The TLV Sniffer is available as a standard model 0023-7350, for use in areas known to be free of combustible gases and vapors, or as an intrinsically safe model 0023-7356, for use in hazardous areas designated Class I, Divisions 1 or 2 by the National Electrical Code. Model 0023-7356 has been certified to be intrinsically safe by the Factory Mutual Laboratories.

Air Sampling Mechanisms

The TLV Sniffer air sampling system consists of a short intake connection leading directly into an interior aluminum air chamber holding the detector, a six-inch length of tubing connecting the chamber and a miniature sample-drawing pump, and a three-inch length of tubing to an exhaust port on the left side of the instrument case.

Combustible Gas Detector

The combustible gas detector consists of an "active" catalytic-coated resistance element to oxidize combustible gas, and an identical second resistance element without the catalyst coating which provides a "reference" resistance value unaltered by the oxidation of combustible gas. Since both operate at approximately equal temperatures, only changes in gas content of sampled air cause differences in resistance between the two to produce signals to the meter and gas alarm circuits. Both active and reference elements are protected within a porous bronze cylinder that plugs into a mounting block attached with four screws to the air chamber block. The three-pronged mounting block connects in turn to a cylindrical plug with wires that connect to circuitry on the instrument circuit board.

AUXILIARY EQUIPMENT

Probe and Hose, 0023-7243, and Dilution Probe and Hose, 0023-7355

A five-foot-long flexible hose and probe assembly, for sampling air at specific points to find exact locations of gas leaks, attaches to a fitting on the left side of the case by means of a snap-fitting, spring-loaded collar that can be drawn back with one hand. A cotton dust filter within the probe protects the sample drawing lines and chamber from intrusion of dust and dirt. The dilution probe 0023-7355 has an O-ring covering holes designed to admit air to dilute the sample 10 times. With O-ring moved to expose dilution holes, the instrument reads up to 100,000 ppm to accommodate sample concentrations above the normal 10,000 ppm limit. (See Figure 3-1.) An in-line filter and trap assembly 23-7341 is available for use in dust- or moisture-laden atmospheres.

Earphones

An earphone set of 100-ohm impedance may be attached to an earphone jack plug on the right side of the TLV Sniffer case wherever noise in an area to be tested obscures the audible signal from the speaker of the instrument. The earphone circuit does not cut out the audible speaker signal when the earphone is attached, but rather provides a second way to hear the signal where noise conditions so require.

Batteries

For standard model TLV Sniffer: The portable TLV Sniffer standard model is powered by six D-size dry-cell batteries inserted in tubes and spring clamps within the instrument case at the rear. Though any kind of D cells may be used, nickel-cadmium rechargeable batteries are recommended for longest uninterrupted service (six to nine hours of continuous service). The instrument circuitry is so designed that an audible tone sounds when battery power falls below that required to sustain gas detection operations.

For intrinsically safe model: The Intrinsically Safe battery pack is similar to above, but the battery consists of six nickel-cadmium cells connected by welded links to prevent arcing. The cell assembly is enclosed in a rivet-sealed, high-impact, plastic housing with protective fuses and wire-wound resistors that limit current capacity even under short-circuit conditions to levels below that which would ignite the worst possible mixtures of combustible gas and air.

Battery Charger

A compact battery charger (230 VAC: #0023-7353; 115 VAC: #0023-7230) with a plug-in connector may be attached to a jack provided in the right side of the instrument case. For stationary testing, the TLV Sniffer may be operated with the charger connected. For portable operations, the charger may be used to rejuvenate batteries within the instrument overnight. The intrinsically safe battery pack may be recharged either in or outside the instrument.

Recorder

A recorder (range: 0-100 mv; impedance: 10,000 ohms or greater) may be connected to the TLV Sniffer for use if variations in combustible gas levels are to be recorded for study or legal data. Recording is more suitable for the PPM X 100 and PPM X 10 mode ranges. The ultrasensitive PPM X 1 "search" range, responsive from 1 to 100 ppm of gas, is not as suitable for an accessory recorder because of the small magnitude of the signal and the potentially rapid fluctuations of the signal within the range in response to small changes in detected quantities of combustible gas.

CONTROLS

Mode Selector

The MODE SELECTOR control knob at lower right on the instrument panel operates a rotating gang switch with an OFF position, a battery test switch, and three range-selector switch positions that allow a choice among three sensitivity ranges for readings of 0 - 100 ppm, 0 - 1000 ppm, or 0 - 10,000 ppm on the meter scale.

ADJUSTMENTS

Meter Zero Mechanical Adjustment Screw

The meter pointer mechanical adjustment screw is located within the instrument on the back side of the meter barrel near the - terminal. This adjustment screw is factory set, and does not ordinarily require subsequent attention. Any adjustment of this screw should be done with the MODE SELECTOR knob turned to the OFF position.

Meter Zero Coarse Adjustment Screw (Figure 1-1)

The meter pointer coarse adjustment is accomplished by means of a small potentiometer adjustment screw located immediately under the ZERO ADJUST knob at lower left on the instrument panel. In fresh air, with power on, with the MODE SELECTOR control knob set to PPM X 100, and with the ZERO ADJUST knob turned to midpoint, this screw should be slowly turned to position the pointer to zero on the meter scale.

Meter Zero Fine Adjustment Knob (Figure 1-1)

In the presence of fresh air, the ZERO ADJUST knob at lower left on the instrument panel may be turned to adjust the meter pointer to zero -- first for the PPM X 100 range, then the PPM X 10 range, and lastly for the PPM X 1 range -- just before using the instrument to detect combustible gas. If adjustment of this control does not bring the pointer to zero, the coarse zero-adjustment screw directly below may be turned to provide a greater latitude of fine-adjust control. If the coarse adjustment eventually fails to provide latitude for the fine-adjust control to operate, in all probability the replacement of an exhausted detector element is indicated.

Gain Potentiometer Adjustment Screws (Figure 1-1)

Three gain potentiometer adjustment screws accessible with the instrument cover removed, are located on the circuit board at lower right within the instrument case. With sample calibration gas of known concentration applied to the air sample intake of the instrument, these screws are turned to adjust amplifier gain for the correct amount of pointer deflection across the meter scale. (See OPERATION Section.) Separate potentiometer screws, marked X10, X100, and X1, are provided for each of the three scales available by means of the MODE SELECTOR knob.

Alarm Level Potentiometer Adjustment Screw (Figure 1-1)

The alarm level adjustment screw may be turned to set the audible alarm to respond at any desired degree of pointer deflection across the meter dial. The standard factory setting, which causes the alarm to respond at a meter reading of 50, may be reset to correspond to the ppm Threshold Limit Value, or to any arbitrary figure.

Record Level Potentiometer Adjustment Screw (Figure 1-1)

The level of signal outputs to an accessory recorder may be set by turning the adjustment screw marked "RECORDER" on the potentiometer assembly within the instrument case at bottom right.

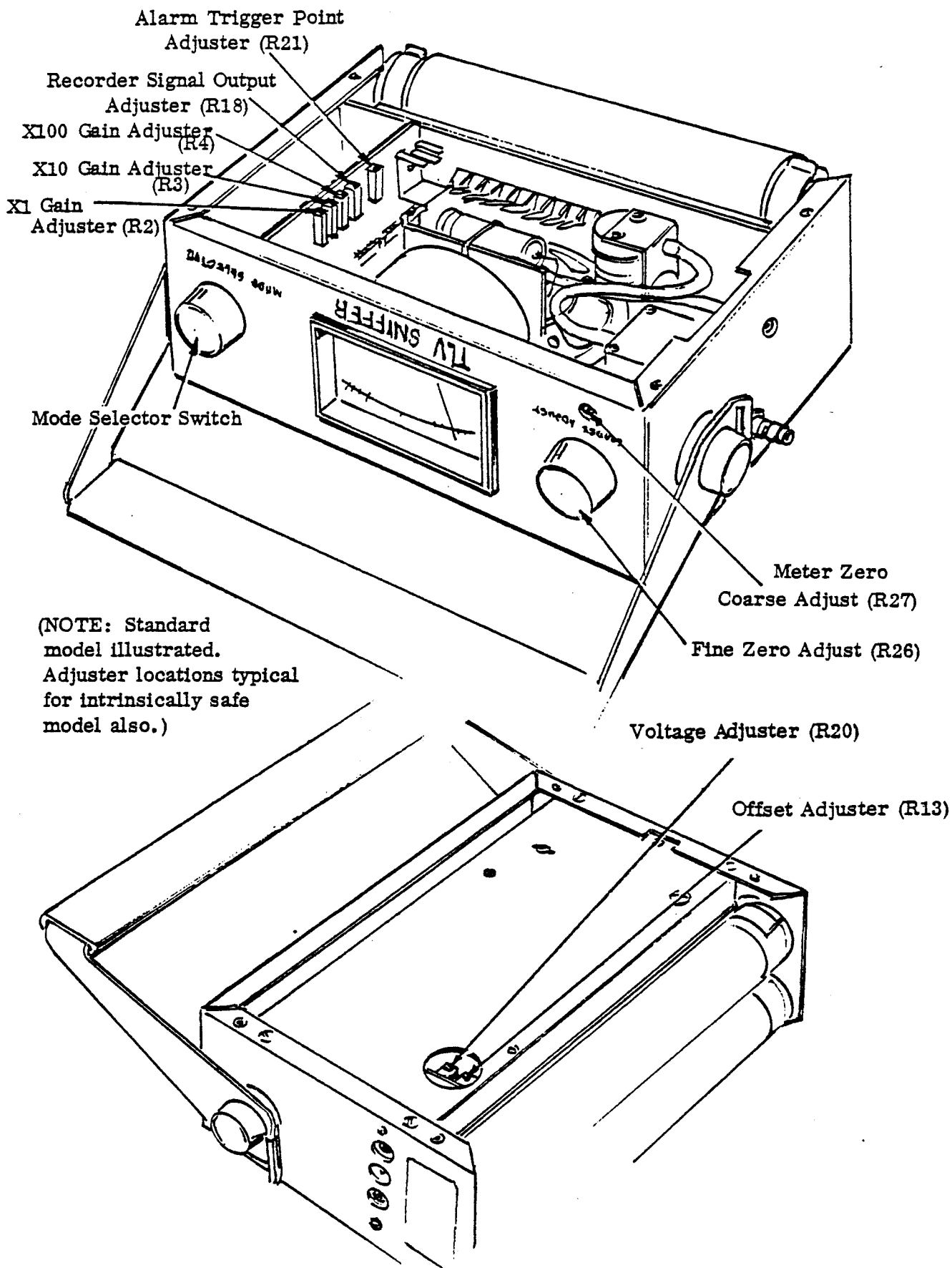

Figure 1-1. TLV Circuitry Adjustment Potentiometer Locations.



SECTION 2PRE-OPERATION CALIBRATIONS AND ADJUSTMENTS

Prepare the TLV Sniffer Combustible Gas Detector for operation in accordance with the following steps:

BATTERY TEST

Test battery as follows: Turn MODE SELECTOR knob from OFF position to BATT TEST position. Meter pointer should come to rest in BATTERY GOOD range of meter scale. (Both a meter reading below BATTERY GOOD range and an audible signal warn of batteries too weak to sustain normal operation.)

SETTING METER POINTER TO ZERO

Set pointer to meter zero as follows:

1. Attach air sampling probe connector to instrument intake on left side of case by pulling back spring collar of connector, pressing connector over intake, and releasing spring collar.
2. Place TLV Sniffer in position in which meter indications will be read (usually in meter-up position).

NOTE: Heat distribution from active and reference filaments of the detector sensor changes from vertical to horizontal position. The resulting change in electrical balance between elements causes a shift in pointer zero from one position to the other.

3. Set MODE SELECTOR switch to PPM X 100 and operate instrument for 10 minutes to allow circuits to stabilize.
4. In fresh air, set ZERO ADJUST knob at midpoint (five full turns from either extreme position). If fresh air is not available, use Bacharach Kit #51-7199 to apply known pure air to the Sniffer intake (instructions in kit).
5. Turn coarse adjustment screw, located under ZERO ADJUST knob, to move meter pointer to zero on the meter scale.
6. Turn MODE SELECTOR to PPM X 10 position and turn ZERO ADJUST knob to set pointer to zero.
7. Turn MODE SELECTOR to PPM X 1 position and turn ZERO ADJUST knob to set pointer to zero.

NOTE: The TLV Sniffer is extremely sensitive in the PPM X 1 range. CO₂ from breath too close to the intake, cigarette smoke, auto fumes, etc., can interfere with accurate setting of the pointer to meter zero.

SETTING METER POINTER DEFLECTION (GAIN CALIBRATION)

Quantitative Gas Test (Refer to Figures 2-1, 2-2, 2-3 and 2-4)

To ensure proper operation and to check calibration, it is necessary to periodically check the instrument against a known, standard blend of calibrating gas.

The Bacharach Code 51-7199 Gas Calibration Kit and optionally available Code 51-1120 Certified Gas Cylinder containing 500 PPM Hexane-in-air are readily available to meet this requirement.

Refer to Figure 2-1, the Calibration Kit consists of the following:

Item No.	Code No.	Description	Qty.
1	51-1201	Flowmeter Mtg. Bracket	1
2	06-6163	Flowmeter	1
3	03-5393	Quick Connect Ftg.	1
4	03-4318	Regulator	1
5	03-5532	Tee 3/16" (plastic)	1
6	03-6351	Rubber Tubing	5 ft.
7	51-1127	Barbed Hose Ftg. (connected to Regulator Assembly)	1
Optional items may be ordered separately:			
8	51-1120	Cylinder Hexane-Air mixture (certified 500 PPM)	1
9. Not Shown	51-7131	Zero Calibration Gas (Compressed Air)	1

Refer to Figure 2-2 and connect the gas transfer assembly as shown, making certain all connections are air-tight. Use the retaining clips (2 each) to mount Flowmeter (06-6163) to its Mounting Bracket (51-1201). Make certain to connect rubber tubing at the base inlet connection on the Flowmeter, then to the barbed fitting on the Regulator and to the Quick Connect fitting previously installed on the TLV Sample-In (inlet fitting). Turn Regulator Valve (03-4318) fully counterclockwise (closed position) before attempting to screw regulator into calibration gas tank.

NOTE: DO NOT OPEN REGULATOR VALVE AT THIS TIME.

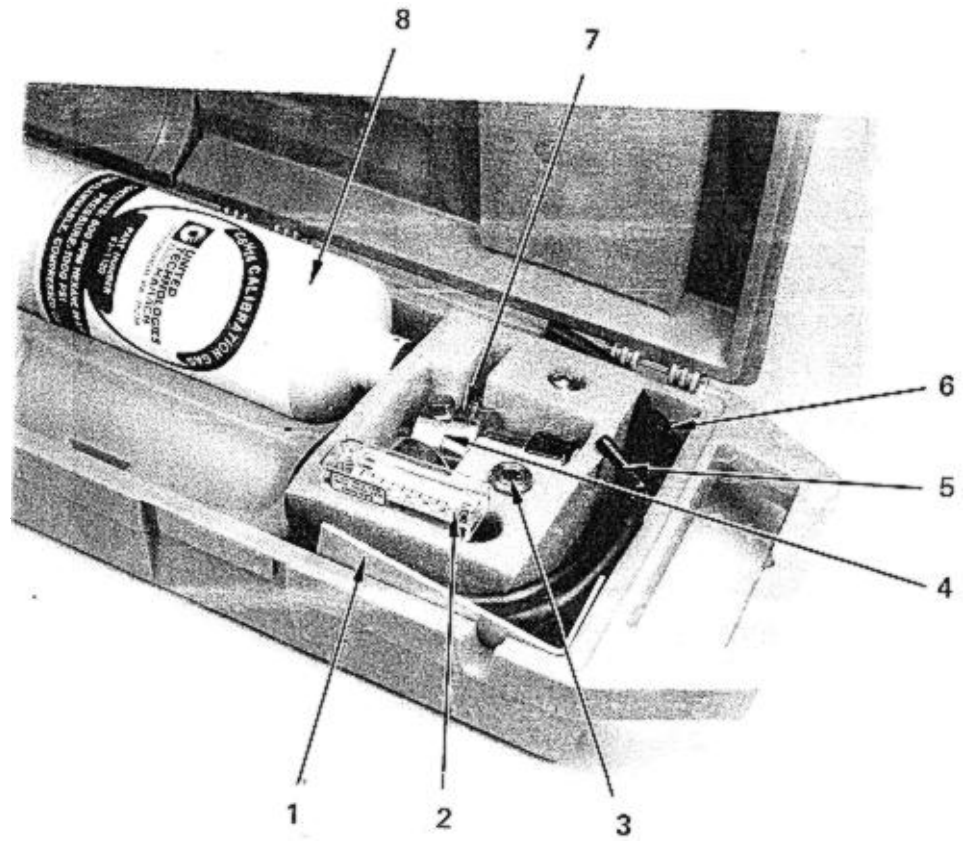

Figure 2-1. Bacharach Code 51-7199 Gas Calibration Kit

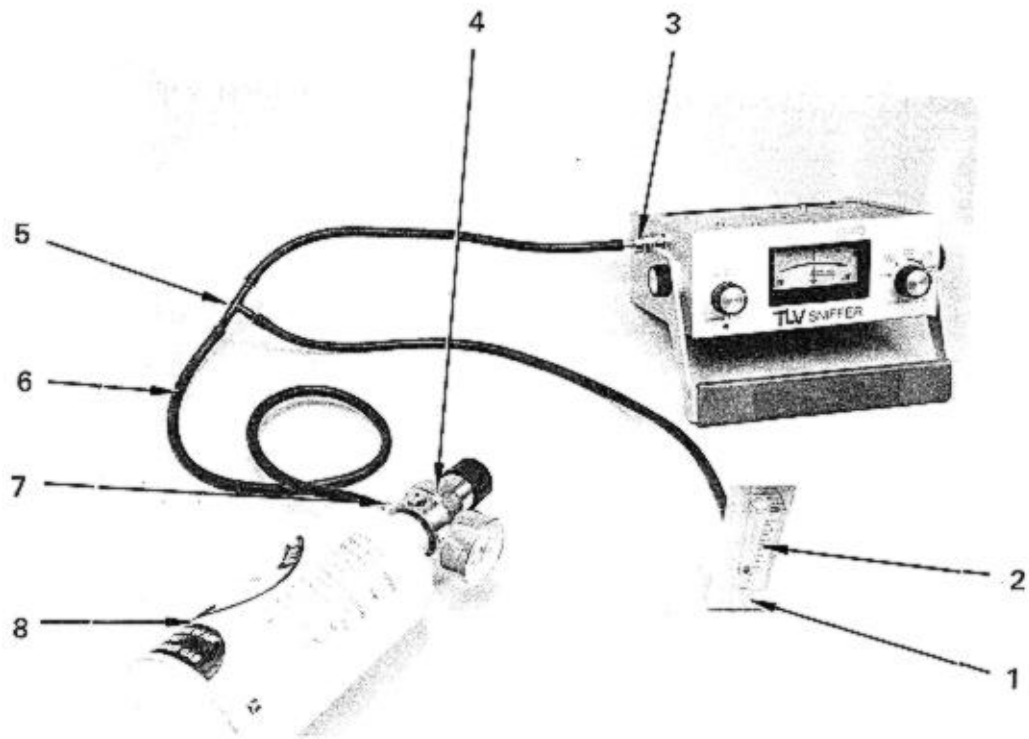

Figure 2-2. Calibration Gas Transfer Assembly Properly Hooked Up.

This test is to be performed in a clean, fresh air (combustible-free) environment. If this is not possible, refer to Figure 2-2 and substitute Code 51-7131 Zero Calibration Gas for the Code 51-1120 Cylinder of Hexane-Air mixture.

Disregard Step 1) and connect the gas transfer assembly at the TLV Sample-In (inlet) fitting before performing Steps 4) and 5).

Open the Regulator Valve (clockwise) and adjust for flowmeter indication of (1) cfh to ensure adequate pump flow.

Remove Code 51-7131 Zero Calibration Gas and substitute the Code 51-1120 Cylinder of Hexane-Air mixture before proceeding with Step 6).

To calibrate the instrument in fresh air (combustible-free) environment, proceed as follows:

- 1) Remove case cover for access to internal adjustments and temporarily break gas transfer assembly connection at the TLV Sample-In (inlet) fitting.
- 2) Turn FINE ZERO ADJUST (pot) full clockwise and then five turns counterclockwise to mid-range. Then turn COARSE ADJUST (pot) full clockwise and then ten turns counterclockwise to mid-range.
- 3) Turn MODE SELECTOR TO BATT. TEST position. The meter pointer must indicate within BATTERY GOOD range, if not recharge.

Refer to Figure 2-4 locating TP-3 and connect a Voltmeter between TP-3 (+) and ground (-), check for 6VDC. If not, refer to Figure 2-3 locating R-20 and adjust for 6VDC \pm .01 VDC.

- 4) After allowing for five-minute warm-up, turn MODE SELECTOR switch to PPMX100 position and adjust R-13 (see Figure 2-3) for meter pointer indication of scale zero.
- 5) Turn MODE SELECTOR switch to PPMX10 position and adjust COARSE ADJUST for meter pointer indication of scale zero. Readjust per Steps 4 and 5 until meter pointer indicates a relatively constant scale zero when MODE SELECTOR is switched between PPMX10 and PPMX100 range.
- 6) Turn MODE SELECTOR switch to PPMX10 position. Reconnect Gas Transfer Assembly to TLV Sample-In (Inlet) fitting. Open Regulator Valve (clockwise) and adjust for Flowmeter indications of (1) cfh to ensure adequate pump flow. Allow one minute for meter pointer to achieve maximum indication (refer to Figure 2-4), adjust R-3 the X10 Span Adjuster until meter pointer indicates mid-scale (50) or 500 ppm. Remove gas, close Regulator Valve (fully CCW) and allow about two minutes for meter pointer to return to zero.

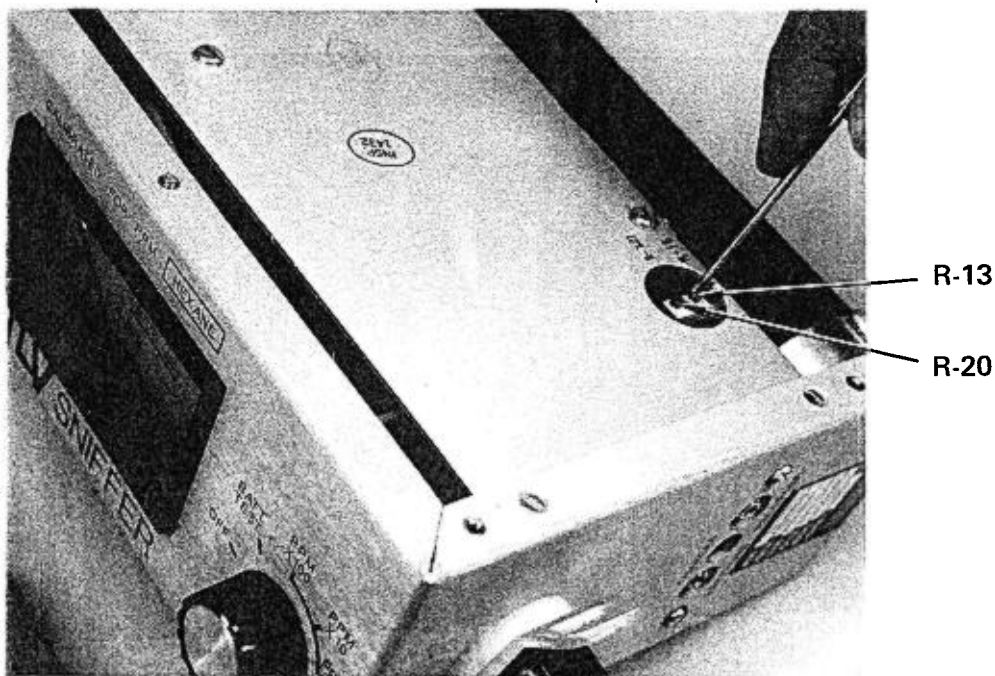

Figure 2-3. Locating and adjusting R-13 on PPMX100 position for meter pointer indication of scale zero.

- 7) Turn MODE SELECT switch to PPMX10 position. Then turn the FINE ZERO ADJUST until meter pointer indicates full scale 1000 ppm. Turn MODE SELECT switch to PPMX100 position and adjust R4 the X100 Span Adjuster until meter pointer indicates (10) or 1000 ppm. Turn FINE ZERO ADJUST until meter pointer indicates scale zero.
- 8) Turn MODE SELECT switch to PPMX10 position, then turn FINE ZERO ADJUST until meter pointer indicates 10 on the scale or 100 ppm.
- 9) Turn MODE SELECT switch to PPMX1 position and adjust the X1 Span Adjuster until meter pointer indicates 100 (full scale) or 100 ppm.
- 10) Turn FINE ZERO ADJUST until meter pointer indicates scale zero. The TLV is now calibrated and ready for use on the low range 0-100 ppm as a gas leak detector.

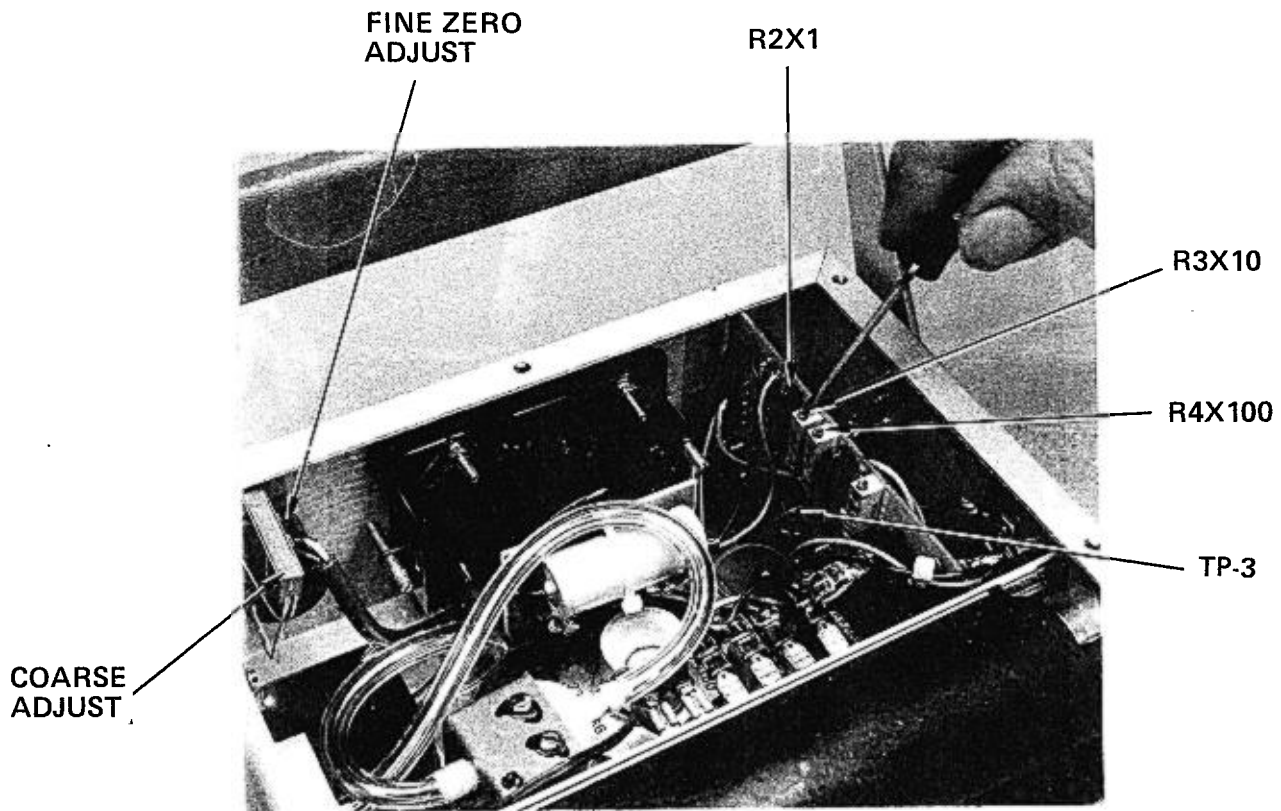

Figure 2-4. Locating and Adjusting R-3 for certified Gas Indication of 500 ppm on the meter.

RESETTING ALARM RESPONSE

If factory set alarm response at midpoint of the meter scale is not suitable, reset alarm response level as follows:

1. Turn meter zero coarse adjustment screw (located under ZERO ADJUST control knob at lower left on instrument panel) to set meter pointer to desired alarm point on meter scale.
2. Turn ALARM potentiometer adjustment screw until audible alarm sounds.
3. Turn meter zero coarse adjustment screw to return pointer to zero on meter scale.

SETTING RECORDING LEVEL

If recorder (range: 0-100 mv; impedance: 10,000 ohms or greater) is to be used, attach accessory recorder jack to RECORDER plug in right side of instrument case and set recording level as follows:

1. Set MODE SELECTOR knob to PPM X 100 or PPM X 10 as desired and apply combustible gas to instrument intake.
2. Turn RECORDER potentiometer adjustment screw until accessory recorder response corresponds with meter readings as desired.



SECTION 3OPERATIONMONITORING TOXICITY

Monitor combustible gas and vapors to determine concentrations with respect to Threshold Limit Values as follows:

Direct Readings and Alarm

1. Turn MODE SELECTOR control knob to BATT TEST position and read condition of battery on meter dial. Install new or recharged batteries if necessary.
2. Turn MODE SELECTOR control to desired operating range, selected in accordance with the Threshold Limit Value for the toxic gas to be monitored (PPM X 1 for TLV from 0 to 100 ppm; PPM X 10 for TLV from 0 to 1000 ppm; PPM X 100 for TLV from 0 to 10,000 ppm).
3. Allow ten-minute warmup period with instrument in same position as it is to be used in service (meter facing up or meter facing to the side).
4. In fresh air before entering monitoring area, turn ZERO ADJUST control knob until meter pointer resets on zero.
5. For monitoring in noisy areas, insert jack of accessory earphone in plug on right side of instrument case.
6. Enter monitoring area and read ppm gas concentrations on meter. Audible warning sounds if gas concentration causes readings at mid-point of scale or above, or if toxic Threshold Limit Value has been exceeded, provided the alarm has been set for this response.
7. For readings above 10,000 ppm: Replace probe assembly 0023-7243 with dilution probe 0023-7355 and slide dilution probe O-ring to expose dilution holes of probe (extends range 10X to read up to 100,000 ppm). See Figure 3-1. Add in-line filter and trap assembly if sampling in dust- or moisture-laden areas.

Converting Hexane-calibrated Meter ppm Readings to ppm Readings for Other Gases

Hexane gas is commonly used for factory calibration and subsequent in-service recalibrations of the TLV Sniffer. To determine ppm concentrations of gases other than hexane with instruments calibrated for hexane, multiply the ppm meter reading by the factor for the gas detected as listed in the table below. (Note meter range setting in making ppm readings and calculations.)

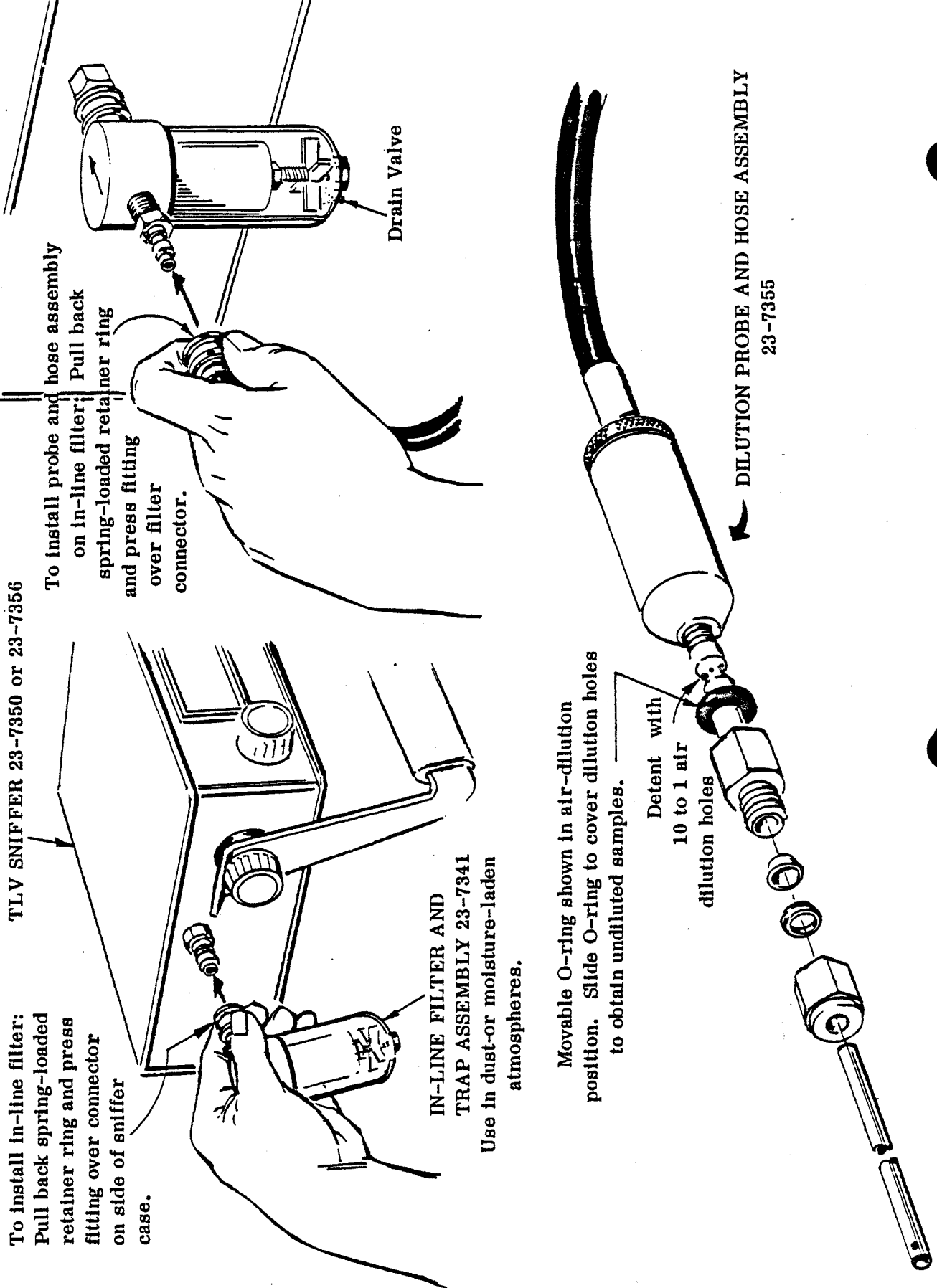

Figure 3-1. Use of Dilution Probe and Hose Assembly and In-line Filter and Trap Assembly.

Table 3-1. Multiplying Factors for Converting ppm Meter Readings of Hexane-calibrated Instruments to ppm Concentrations of Other Gases. (Approximations)

Gas Detected	Factor	Gas Detected	Factor
Acetone	1.50	Hydrogen Sulfide	18.60
Acetylene	1.78	Isopropanol	1.59
Acrylonitrile	1.54	M.E.K.	1.60
Benzene	1.02	Methane	1.58
1,3-Butadiene	1.52	Methanol	3.71
Butane	1.04	Methyl Acrylate	3.37
Butyl Acetate	2.08	Methyl Chloride	4.02
Carbon Disulfide	5.92	Methyl Chloroform	4.44
Carbon Monoxide	5.11	Pentane	1.04
Cyclohexane	1.02	Perchloroethylene	13.66
Ethane	1.36	Propane	1.14
Ethanol	1.90	Propylene	1.30
Ethyl Acetate	2.22	Styrene	2.25
Ethyl Ether	1.30	Tetrahydrofuran	1.41
Ethylene	1.38	Toluene	1.03
Ethylene Oxide	2.05	Trichloroethylene	6.40
Heptane	1.05	Vinyl Acetate	2.00
Hexane	1.00	Vinyl Chloride	2.24
Hydrogen	1.45	o-Xylene	1.64

Converting ppm Readings to Percent Level of Lower Explosive Limit (%L.E.L.)

To determine gas concentration levels in terms of percent of lower explosive limit (% L.E.L.) from direct ppm readings for hexane or from calculated ppm concentration levels for other gases:

1. Read ppm on TLV Sniffer indicating meter.
2. On 0-to-10,000 "PPM CONCENTRATION IN SAMPLE" horizontal scale at bottom of % L.E.L. Conversion Chart, Figure 3-2, locate position left-to-right representing ppm reading.
3. On slanted chart line representing kind of gas detected, find the point in vertical alignment over ppm reading point on horizontal scale.
4. On vertical scale at left labeled "% L.E.L. EQUIVALENT," read the percent-of-lower-limit equivalent found in horizontal alignment with the point located on the slanted line.

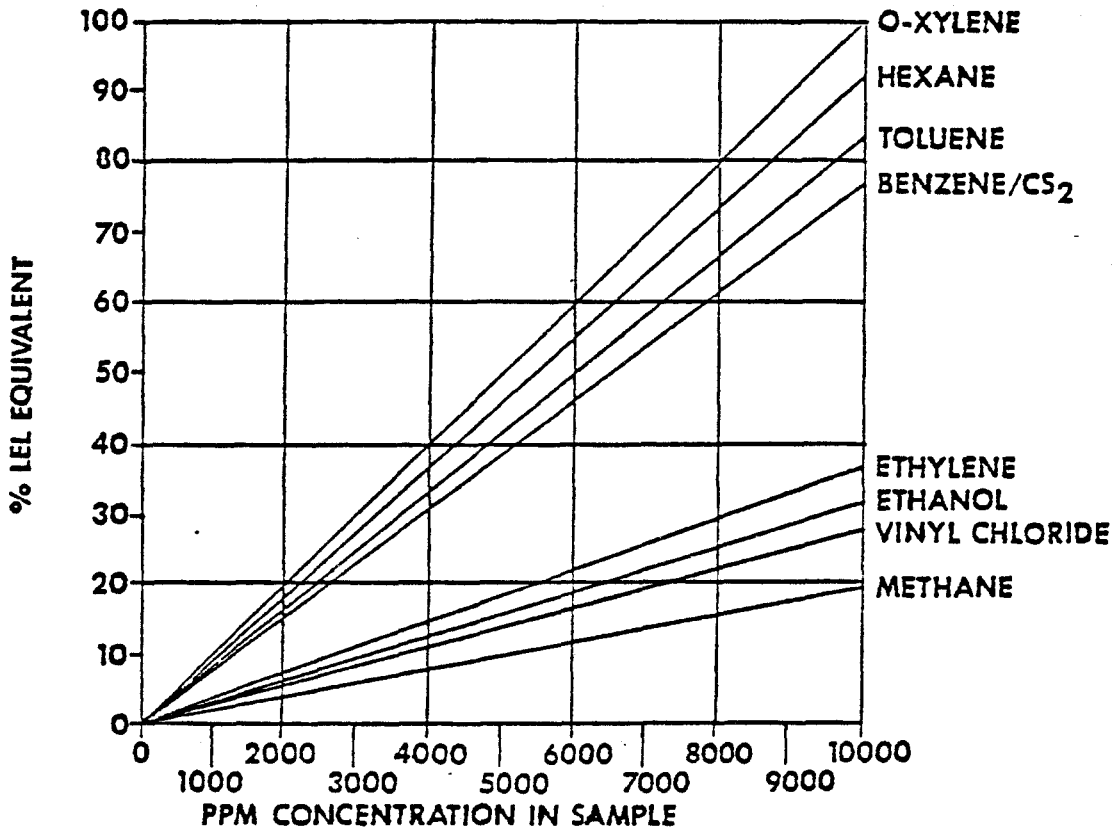

Figure 3-2. Conversion Curves Showing Relationship of PPM Concentrations of Various Gases to Percent L.E.L. Approximate Equivalents.

LOCATING GAS LEAK SOURCES

To utilize the TLV Sniffer in searching for gas leaks in tanks, pipes, hoses, containers, etc.:

1. Set MODE SELECTOR control knob to PPM X 1 position.
2. Search for exact location of leak with probe. Meter reading will increase as leak is approached and decrease as probe moves away from leak.

SECTION 4

MAINTENANCE AND REPAIRS

SYMPTOMS AND REMEDIES

Gradual exhaustion of the detector element, eventual wearing of air-sample pump parts, battery recharging or replacement, etc., require an amount of maintenance and repair work over an extended period of time. The following table describes symptoms, possible causes, and remedial actions relating to conditions requiring maintenance and repairs.

TABLE 4-1

TROUBLESHOOTING PROCEDURES

SYMPTOM	POSSIBLE CAUSE	REMEDY
Meter pointer drifts from zero.	Traces of combustible gas in air sample thought to be pure.	Adjust pointer to zero in fresh air. Use Bacharach Kit 51-7199 if fresh air is otherwise unavailable.
	Change of position of instrument from upright to horizontal or vice versa, thus redistributing heat between active and reference elements of the detector.	Keep instrument consistently in either vertical or horizontal position while in use.
	Insufficient warmup period.	Allow 10-minute warmup period before zeroing meter pointer.
	Erratic monolithic chip.	Consult factory or replace circuit board.
	Erratic sensing element.	Replace detector.

TABLE 4-1 (continued)

SYMPTOM	POSSIBLE CAUSE	REMEDY
False sounding of audible gas alarm. (Meter reads in alarm zone)	Change of position of instrument distributes more heat to detector active element.	Keep instrument consistently in one position while in use.
	Intrusion of cigarette smoke, auto fumes, or other common combustible gases or vapors.	Wait for intruding combustibles to pass; move away from source; remove source.
	Incorrect setting of alarm level.	Reset alarm level consistent with appropriate Threshold Limit Value.
	Faulty monolithic chip.	Consult factory or replace printed circuit board.
	Faulty detector or detector lead connections.	Replace detector; make lead connections clean and tight.
Continuous tone audible signal; meter pointer to left of BATTERY GOOD zone of meter with control set to BATT TEST.	Run-down battery.	Recharge or replace batteries.
Negative (downscale) drift of meter pointer (audible alarm sounds at minus 10%)	Meter pointer set to zero on impure air sample, then responding to purer air.	Set pointer to zero with pure air sample.
	Faulty detector.	Replace detector.
	Faulty monolithic chip.	Consult factory or replace circuit board.

TABLE 4-1 (continued)

SYMPTOM	POSSIBLE CAUSE	REMEDY
No audible alarm in presence of strong concentration of combustible gas.	Operation of 45-second delay circuit after turning MODE SELECTOR control to operate instrument.	Wait approximately 45 seconds for delay period to expire.
	Improper setting of alarm response level.	Reset alarm to desired level.
	Faulty monolithic chip.	Consult factory or replace circuit board.
	Faulty alarm circuit.	Replace printed circuit board.
	Loose lead to speaker; damaged speaker.	Inspect for loose leads. Using 0-15V range voltmeter, check for excitation voltage across speaker terminals while meter indicates in alarm zone.
Dead batteries.	Confirm battery exhaustion at meter with MODE SELECTOR switch in BATT TEST position. Recharge or replace batteries if necessary.	

TABLE 4-1 (continued)

SYMPTOM	POSSIBLE CAUSE	REMEDY
Inability to set calibration for proper reading on known gas sample.	Error in sample; sample cylinder empty.	Apply another known gas sample; compare sample response with that of a known good instrument.
	Inadequate sample flow.	Check for air leak in sample hose, probe, or external connections. (Plugging probe inlet will stall pump if no leak exists.) Examine pump piston and diaphragm. Repair or replace faulty components and parts.
	If in only one range: faulty calibration.	Check potentiometer resistance with ohmmeter. Replace if necessary.
	Faulty sensing element.	Replace detector.

Replacing Batteries

Replace batteries, if necessary, as follows:

1. Remove ten screws used to hold cover to case and remove cover.
2. Standard model: Remove two battery assemblies (three batteries in each of two cardboard tubes) from spring clips in back of case.

Intrinsically safe model: Replace entire sealed battery pack. The following steps 3 and 4 do not apply.
3. Standard model: Remove old batteries from tubes and replace with new batteries. Orient plus and minus battery terminals as indicated by arrows with polarity signs on battery mounting panel.
4. Standard model: Snap replacement batteries with tubes into battery holding clips. Spring terminals at one end may be held back with a small screwdriver or similar tool to facilitate insertion of battery assemblies in clips.
5. Replace cover and attach with ten screws.

Replacing Detector

Replace detector when necessary as follows:

1. Remove instrument case cover to gain access to detector housing.
2. With instrument in speaker-down position, remove four screws used to attach detector socket assembly to cubical aluminum air sample chamber.
3. Lift detector socket assembly from air chamber block.
4. Unplug old detector from socket assembly.
5. Insert new detector in socket. New detector part number should correspond to that listed on label affixed to cover of instrument (#800-080.90).
6. Reinstall socket assembly with new detector in air chamber and replace instrument cover. Tighten screws uniformly and snugly.

Replacing Printed Circuit Board

Replace printed circuit board, when necessary, as follows:

1. Remove instrument case cover to gain access to printed circuit board.
2. Using Allen wrench, remove two small setscrews used to hold MODE SELECTOR knob to shaft and remove knob from shaft.
3. Remove hex head nut used to hold MODE SELECTOR switch shaft to instrument panel.

4. Using hex head nut driver, remove plugs and insulating washers for recorder and earphone jacks on outside of instrument case.
5. Remove two screws used to attach battery charger plug to case.
6. Disconnect terminal clips and soldered connections of all wires leading from printed circuit board to battery terminal block, speaker, meter, coarse zero adjustment potentiometer, and fine zero adjust potentiometer.
7. Remove four screws used to hold speaker mounting panel to instrument case.
8. Slide speaker mounting panel as necessary to free recorder and earphone plugs and MODE SELECTOR shaft from case. Remove circuit board from case.
9. Install new circuit board, part #23-4441.

Replacing Sample Pump

Replace air sample pump, when necessary, as follows:

1. Remove cover of instrument case to gain access to air sample pump.
2. Turn fastener stud #0002-8059 1/4 turn to release miniature pump assembly from chassis panel.
3. Disconnect pump motor leadwire terminals from battery terminal strip.
4. Disconnect flexible plastic sample tubes from intake and exhaust ports of pump air chamber.
5. Remove pump assembly from instrument.
6. Install replacement pump and connect motor leadwires and flexible plastic tubes as shown in Figure 4-1.
7. Operate instrument to test new pump. Replace cover.

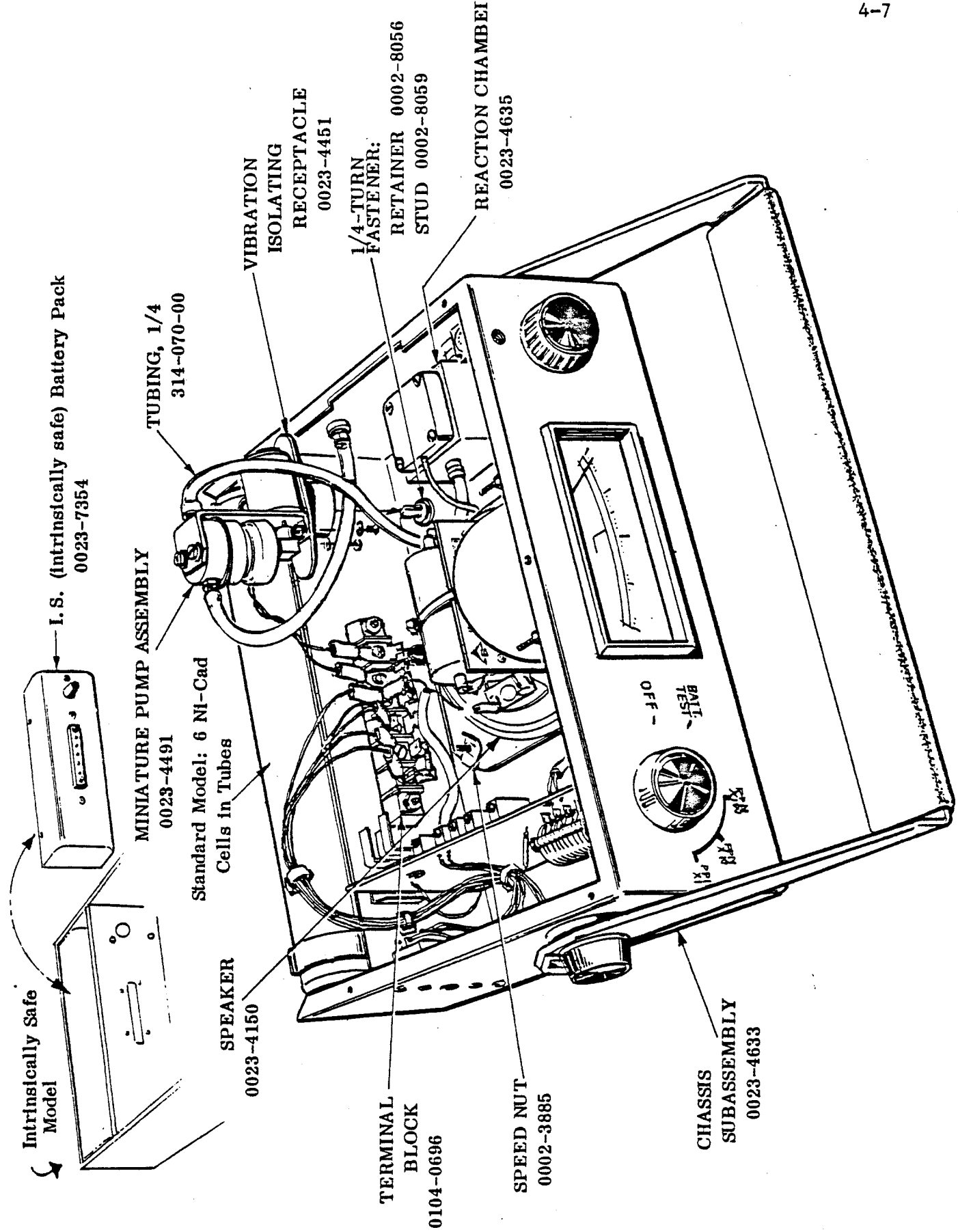

Figure 4-1. TLV Sniffer Chassis Subassembly Showing Miniature Pump Assembly in Disassembled Position.

REPLACEMENT PARTS LISTTLV SNIFFER (Standard Model 0023-7350; Intrinsically Safe Model 0023-7356)

<u>ITEM</u>	<u>STOCK NO.</u>
Calibration Kit	0051-7199
Connector, Tubing	0003-6152
Cover, Instrument	0023-4454
* Dry Cell (alternate to Ni-Cad Cell; 6 required)	3600-3100
Earphone	0023-0605
Element, Detector	8000-8090
Filter, In-line Dust and Moisture Trap	0023-7341
Filter, Probe (box of 24 refills)	5500-7000
Fuse (for Intrinsically Safe battery pack)	0204-2703
Handle	0023-4445
Hexane Tank (500 ppm)	0051-1120
** I.S. (Intrinsically Safe) Battery Pack	0023-7354
Knob, Control	0023-4443
Knob, Handle	0023-4444
* Ni-Cad Cell (preferred for standard model; 6 required)	0004-0030
* Printed Circuit Board Assembly-Std. Model	0023-4441
** Printed Circuit Board Assembly-Intrinsically Safe	0023-4778
Probe and Hose Assembly	0023-7243
Probe and Hose Assembly, Dilution	0023-7355
Pump Assembly	0023-4773
Pump Bellows (replacement)	0023-0018
Pump Check Valve (replacement; 2 required)	0023-4218
Recorder Plug, Switchcraft #755	----
Screw, Cover Mounting (10 required)	01-3461
Finishing Washer (10 required)	102-4062
Spacer, Handle	0023-4647
Speaker	0023-4150
* Tube, Battery (standard model; 2 required)	23-2313
Tubing, 1/4 O.D. x 1/16 wall	03-6105

- * Standard model only
 ** Intrinsically safe model only

