

ROTRON® Regenerative Blowers

EN 523 & CP 523

Sealed High Pressure Regenerative Blower w/Explosion-Proof Motor

FEATURES

- Manufactured in the USA – ISO 9001 compliant
- Maximum flow: 84 SCFM
- Maximum pressure: 158 IWG
- Maximum vacuum: 135 IWG
- Standard motor: 3.0 HP, explosion-proof
- Cast aluminum blower housing, cover, impeller & manifold; cast iron flanges (threaded); teflon lip seal
- UL & CSA approved motor with permanently sealed ball bearings for explosive gas atmospheres Class I Group D minimum
- Sealed blower assembly
- Quiet operation within OSHA standards

MOTOR OPTIONS

- International voltage & frequency (Hz)
- Chemical duty, high efficiency, inverter duty or industry-specific designs
- Various horsepower for application-specific needs

BLOWER OPTIONS

- Corrosion resistant surface treatments & sealing options
- Remote drive (motorless) models
- Slip-on or face flanges for application-specific needs

ACCESSORIES (See Catalog Accessory Section)

- Flowmeters reading in SCFM
- Filters & moisture separators
- Pressure gauges, vacuum gauges & relief valves
- Switches – air flow, pressure, vacuum or temperature
- External mufflers for additional silencing
- Air knives (used on blow-off applications)
- Variable frequency drive package



BLOWER PERFORMANCE AT STANDARD CONDITIONS

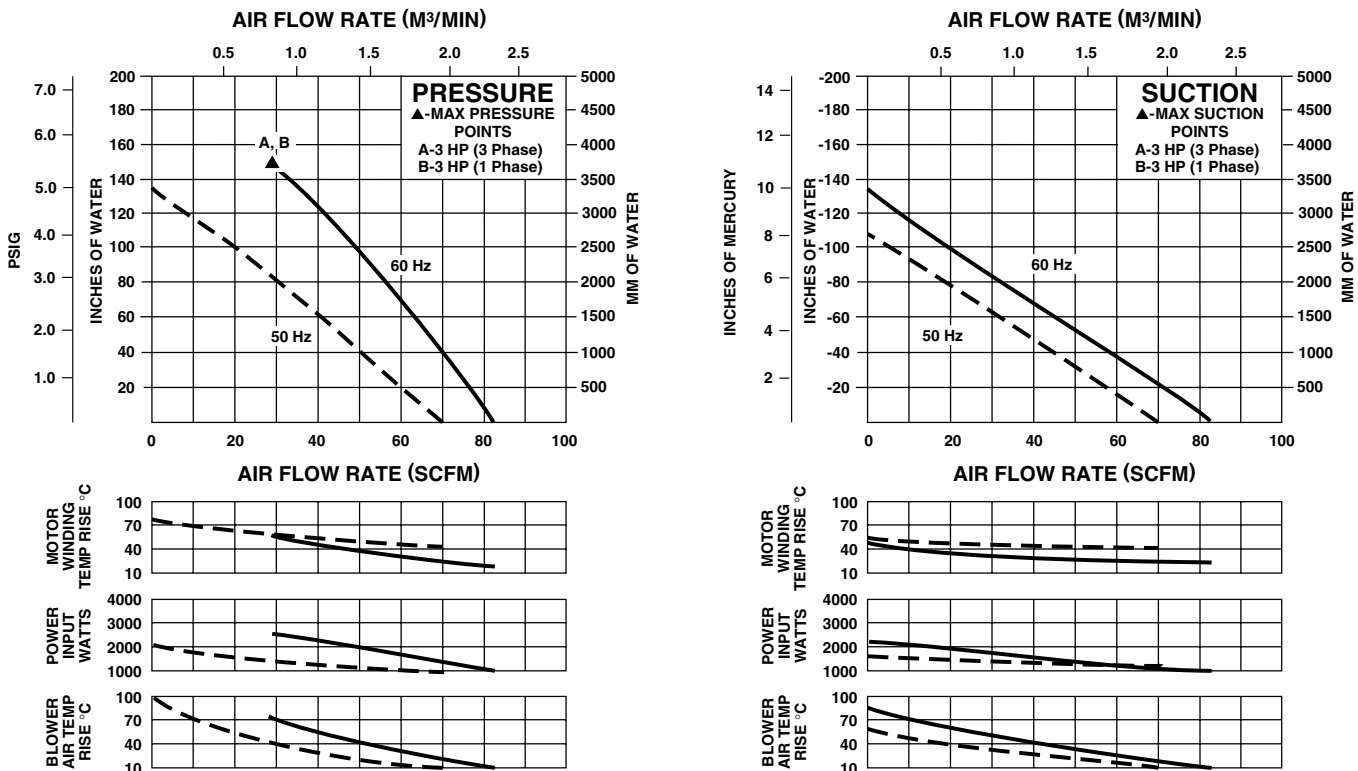

Rev. 2/04

ROTRON® Regenerative Blowers

EN 523 & CP 523

Sealed High Pressure Regenerative Blower w/Explosion-Proof Motor

Scale CAD drawing available upon request.

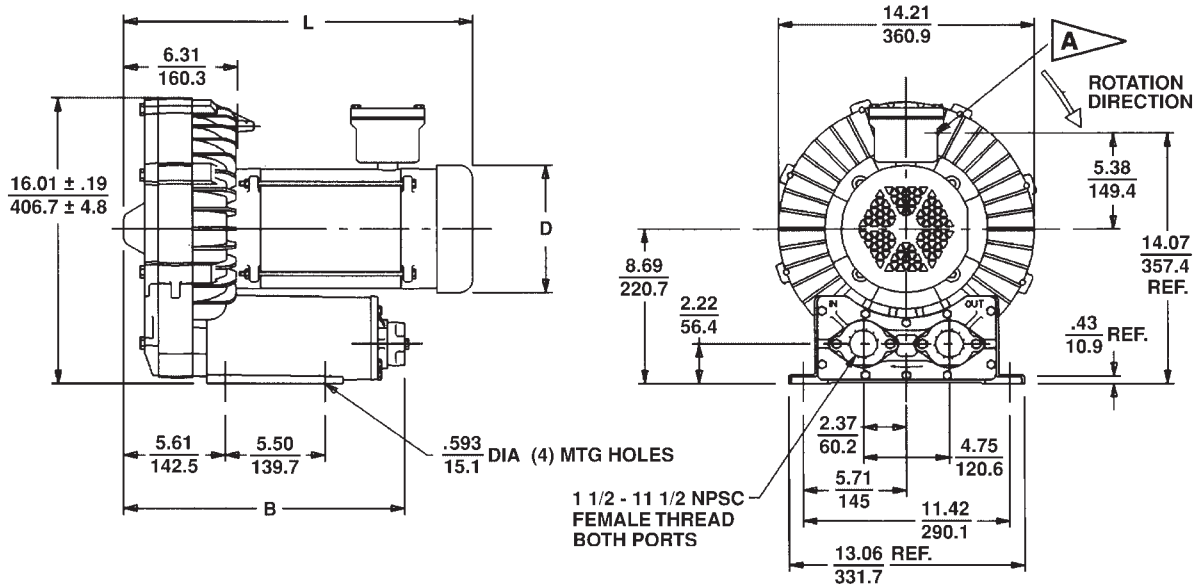

A 0.75" NPT CONDUIT CONNECTION AT 12 O'CLOCK POSITION

DIMENSIONS: $\frac{IN}{MM}$
 TOLERANCES: $.XX \pm \frac{.1}{2.5}$
 (UNLESS OTHERWISE NOTED)

MODEL	L (IN) ± .3	L (MM) ± 8	D (IN) ± .1	D(MM) ± 3	B ± .19	B ± 5MM
EN/CP523M72L	19.3	491	7.2	183	15.76	400
EN/CP523M5L	21.66	550	8.5	216	15.76	400

SPECIFICATIONS

MODEL	EN523M5L	EN523M72L	CP523FU5LR	CP523FU72LR
Part No.	038223	038184	-	038968
Motor Enclosure – Shaft Material	Explosion-proof – CS	Explosion-proof – CS	Chem XP – SS	Chem XP – SS
Horsepower	3.0	3.0	Same as EN523M5L – 038223 except add Chemical Processing (CP) features from catalog inside front cover	Same as EN523M72L – 038184 except add Chemical Processing (CP) features from catalog inside front cover
Phase – Frequency ¹	Single - 60 Hz	Three - 60 Hz		
Voltage ¹	208-230	230 460		
Motor Nameplate Amps	15.5-14.5	7.4 3.7		
Max. Blower Amps ³	18.1-16.7	7.6 3.8		
Inrush Amps	94-88	62 31		
Starter Size	1	0 0		
Service Factor	1.0	1.0		
Thermal Protection ²	Class B - Pilot Duty	Class B - Pilot Duty		
XP Motor Class – Group	I-D	I-D		
Shipping Weight	222 lb (100 kg)	198 lb (90 kg)		

¹ Rotron motors are designed to handle a broad range of world voltages and power supply variations. Our dual voltage 3 phase motors are factory tested and certified to operate on both: **208-230/415-460 VAC-3 ph-60 Hz** and **190-208/380-415 VAC-3 ph-50 Hz**. Our dual voltage 1 phase motors are factory tested and certified to operate on both: **104-115/208-230 VAC-1 ph-60 Hz** and **100-110/200-220 VAC-1 ph-50 Hz**. All voltages above can handle a ±10% voltage fluctuation. Special wound motors can be ordered for voltages outside our certified range.

² Maximum operating temperature: Motor winding temperature (winding rise plus ambient) should not exceed 140°C for Class F rated motors or 120°C for Class B rated motors. Blower outlet air temperature should not exceed 140°C (air temperature rise plus inlet temperature). Performance curve maximum pressure and suction points are based on a 40°C inlet and ambient temperature. Consult factory for inlet or ambient temperatures above 40°C.

³ Maximum blower amps corresponds to the performance point at which the motor or blower temperature rise with a 40°C inlet and/or ambient temperature reaches the maximum operating temperature.

Specifications subject to change without notice. Please consult your Local Field Sales Engineer for specification updates.

Rev. 2/04